

Superposition (Diffraction & Interference)

TOPIC QUESTIONS (2)

Level	AS Level
Subject	Physics
Exam Board	CIE
Paper Type	Multiple Choice

Time Allowed : 1Hour 10Min

EXAM PAPERS PRACTICE

1. Which of the following is a longitudinal wave?

- A a light wave travelling through air
- B a radio wave from a broadcasting station
- C a ripple on the surface of water
- D a sound wave travelling through air

2. A stationary sound wave is set up along the line joining two loudspeakers. Which measurement is sufficient on its own to enable you to deduce the wavelength of the wave?

- A the amplitude of the sound wave
- B the distance between the two loudspeakers
- C the distance between two adjacent antinodes
- D the frequency of the sound wave

3. A wave of amplitude 20 mm has intensity I_X . Another wave of the same frequency but of amplitude 5 mm has intensity I_Y .

What is $\frac{I_X}{I_Y}$?

- A 2
- B 4
- C 16
- D 256

4. The diagram represents a stationary wave on a stretched string.

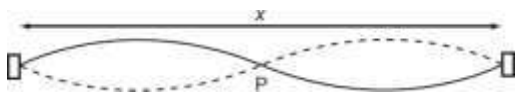

What is represented by point P and by the length x?

	point P	length x
A	antinode	one wavelength
B	antinode	two wavelengths
C	node	one wavelength
D	node	two wavelengths

5. Fringes of separation y are observed on a screen 1.00 m from a Young's slit arrangement that is illuminated by yellow light of wavelength 600 nm.

At which distance from the slits would fringes of the same separation y be observed when using blue light of wavelength 400 nm?

- A 0.33 m
- B 0.67 m
- C 0.75 m
- D 1.50 m

6. Light of wavelength 700 nm is incident on a pair of slits, forming fringes 3.0 mm apart on a screen.

What is the fringe spacing when light of wavelength 350 nm is used and the slit separation is doubled?

- A 0.75 mm B 1.5 mm C 3.0 mm D 6.0 mm

7. Monochromatic light illuminates two narrow parallel slits. The interference pattern which results is observed on a screen some distance beyond the slits.

Which change increases the separation between the dark lines of the interference pattern?

- A decreasing the distance between the screen and the slits
B increasing the distance between the slits
C using monochromatic light of higher frequency
D using monochromatic light of longer wavelength

8. A narrow beam of monochromatic light is incident normally on a diffraction grating. Third-order diffracted beams are formed at angles of 45° to the original direction.

What is the highest order of diffracted beam produced by this grating?

- A 3rd B 4th C 5th D 6th

9. A two-slit arrangement is set up to produce interference fringes on a screen. The fringes are too close together for convenient observation when a monochromatic source of violet light is used.

In which way would it be possible to increase the separation of the fringes?

- A Decrease the distance between the screen and the slits.
- B Increase the distance between the two slits.
- C Increase the width of each slit.
- D Use a monochromatic source of red light.

10. Continuous water waves are diffracted through a gap in a barrier in a ripple tank.

Which change will cause the diffraction of the waves to increase?

- A increasing the frequency of the waves
- B increasing the width of the gap
- C reducing the wavelength of the waves
- D reducing the width of the gap

11. A stationary wave on a stretched string is set up between two points P and T.

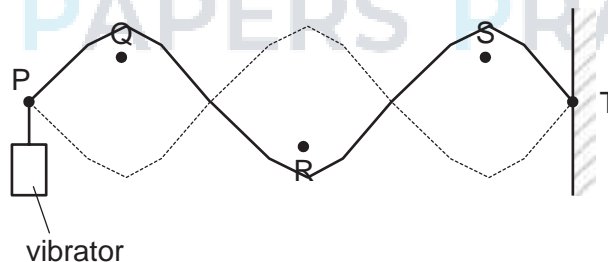

Which statement about the wave is correct?

- A Point R is at a node.
- B Points Q and S vibrate in phase.
- C The distance between P and T is three wavelengths.
- D The wave shown has the lowest possible frequency.

12. The basic principle of note production in a horn is to set up a stationary wave in an air column.

For more help, please visit www.exampaperspractice.co.uk

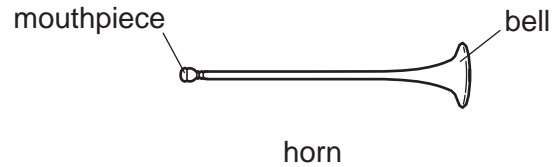

For any note produced by the horn, a node is formed at the mouthpiece and an antinode is formed at the bell. The frequency of the lowest note is 75 Hz.

What are the frequencies of the next two higher notes for this air column?

	first higher note /Hz	second higher note /Hz
A	113	150
B	150	225
C	150	300
D	225	375

13. A stationary wave is set up on a stretched string, as shown.

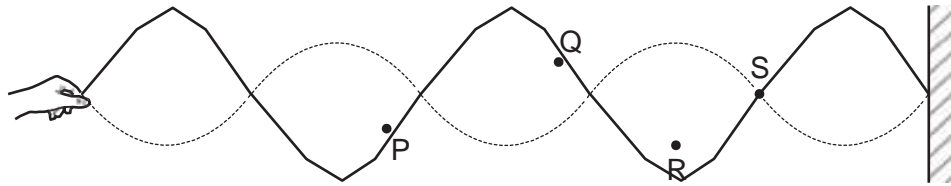

Which statement about the points on the string is correct?

- A Point Q vibrates with the largest amplitude.
- B Points P and R vibrate in phase.
- C Point S is an antinode.
- D The horizontal distance between R and S is half the wavelength.

14. The diagram shows a sketch of a wave pattern, over a short period of time.

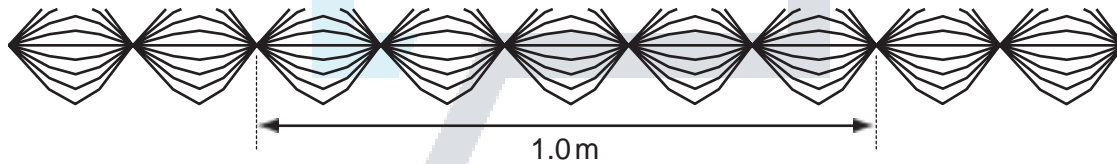

Which description of this wave is correct?

- A The wave is longitudinal, has a wavelength of 20 cm and is stationary.
- B The wave is transverse, has a wavelength of 20 cm and is stationary.
- C The wave is transverse, has a wavelength of 40 cm and is progressive.
- D The wave is transverse, has a wavelength of 40 cm and is stationary.

15. The sound from a loudspeaker placed above a tube causes resonance of the air in the tube.
 A stationary wave is formed with two nodes and two antinodes as shown.

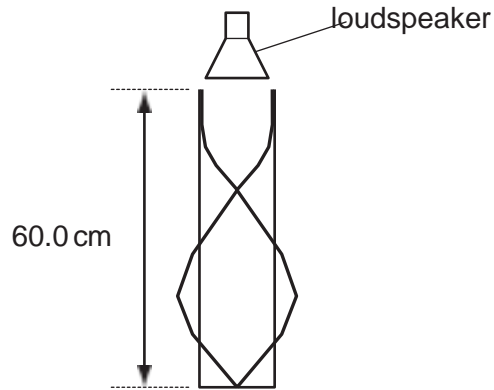

The speed of sound in air is 330 m s^{-1} .

What is the frequency of the sound?

- A 413 Hz B 550 Hz C 830 Hz D 1650 Hz

16. Two identical loudspeakers are connected in series to an a.c. supply, as shown.

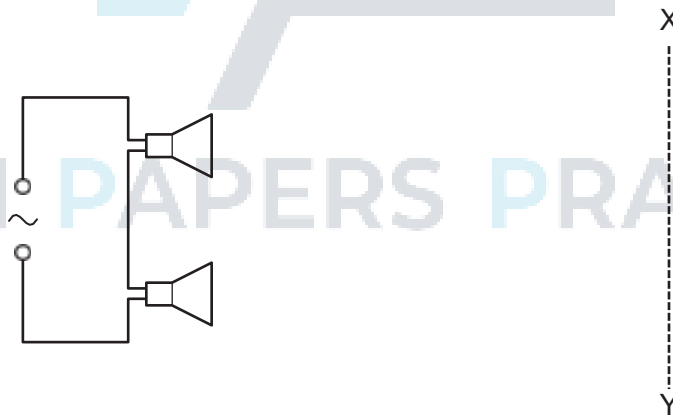

Which graph best shows the variation of the intensity of the sound with distance along the line XY?

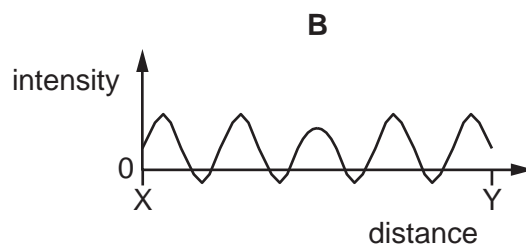
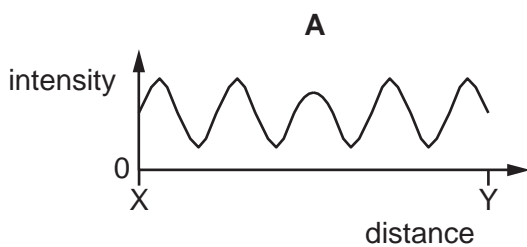

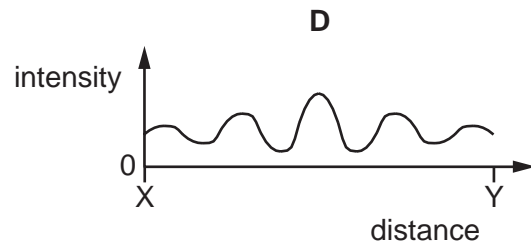
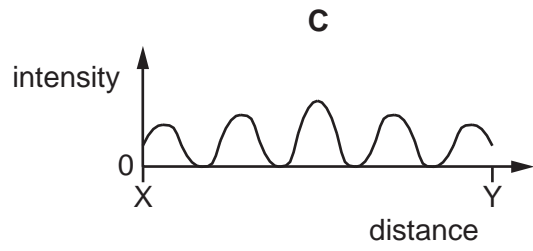

EXAM PAPERS PRACTICE

17. A diffraction grating experiment is set up using yellow light of wavelength 600 nm. The grating has a slit separation of $2.00 \mu\text{m}$.

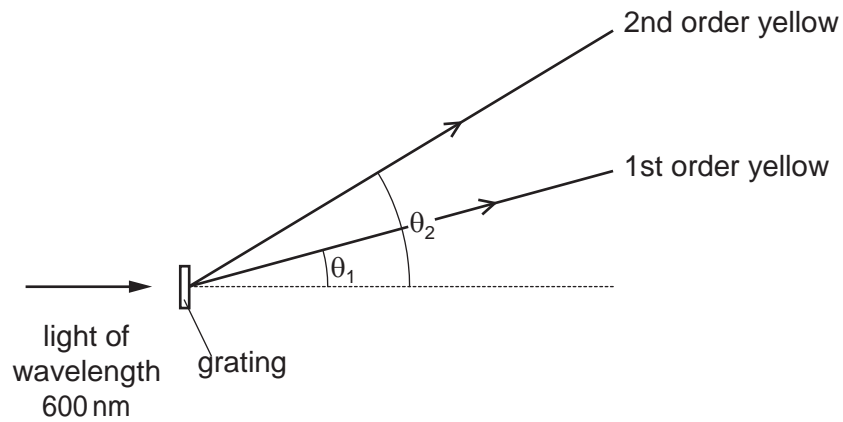

What is the angular separation ($\theta_2 - \theta_1$) between the first and second order maxima of the yellow light?

- A 17.5° B 19.4° C 36.9° D 54.3°

18. Plane wavefronts in a ripple tank pass through a gap as shown.



For more help, please visit www.exampaperspractice.co.uk

19. Interference fringes are produced on a screen by double-slit interference using light of wavelength 600 nm. The fringe separation is 4.0 mm and the separation of the slits is 0.60 mm.

What is the distance between the double slit and the screen?

- A 0.25 m B 0.40 m C 2.5 m D 4.0 m

20. A parallel beam of white light passes through a diffraction grating. Orange light of wavelength 600 nm in the fourth order diffraction maximum coincides with blue light in the fifth order diffraction maximum.

What is the wavelength of the blue light?

- A 450 nm B 480 nm C 500 nm D 750 nm

21. The diagram shows a standing wave on a string. The standing wave has three nodes N_1 , N_2 and N_3 .

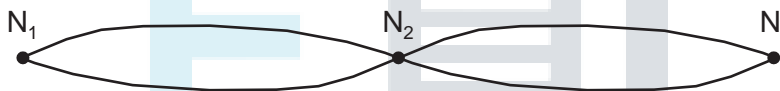

Which statement is correct?

- A All points on the string vibrate in phase.
 B All points on the string vibrate with the same amplitude.
 C Points equidistant from N_2 vibrate with the same frequency and in phase.
 D Points equidistant from N_2 vibrate with the same frequency and the same amplitude.

22. A musical organ produces notes by blowing air into a set of pipes that are open at one end and closed at the other.

What is the lowest frequency of sound produced by a pipe of length 10 m?
 (The speed of sound in the pipe is 320 m s^{-1} .)

- A 4 Hz B 8 Hz C 16 Hz D 32 Hz

23. A horizontal glass tube, closed at one end, has a layer of dust laid inside it on its lower side. Sound is emitted from a loudspeaker that is placed near the open end of the tube.

The frequency of the sound is varied and, at one frequency, a stationary wave is formed inside the tube so that the dust forms small heaps.

The distance between four heaps of dust is 30 cm.

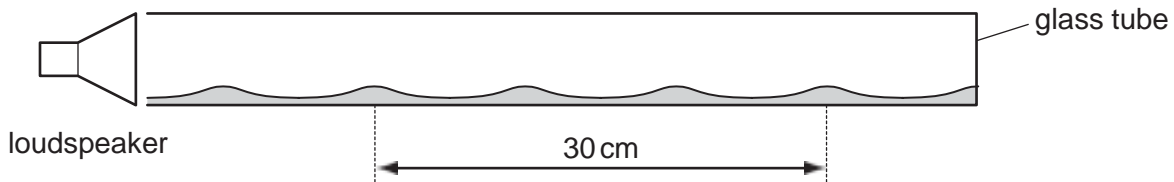

The speed of sound in the tube is 330 m s^{-1} .

What is the frequency of the sound emitted by the loudspeaker?

- A 1650 Hz B 2200 Hz C 3300 Hz D 6600 Hz
24. A stationary sound wave is formed in a measuring cylinder by blowing across the top, as shown.



Which statement is correct?

- A The fundamental frequency of the stationary wave decreases when some water is added to the cylinder.
- B The stationary wave in the cylinder is caused by the superposition of two waves moving in opposite directions.
- C The stationary wave in the cylinder is polarised.
- D The stationary wave will have an antinode at the bottom of the cylinder.

25. To produce a stationary wave, two waves must travel in opposite directions through the same space.

Which statement about the properties of the two waves must also be true?

- A The waves must have equal frequency, but a different speed and wavelength.
- B The waves must have equal speed, but a different wavelength and frequency.
- C The waves must have equal speed, frequency and wavelength.
- D The waves must have equal wavelength, but a different speed and frequency.

26. The diagram shows two identical loudspeakers driven in phase by a common audio-frequency source.

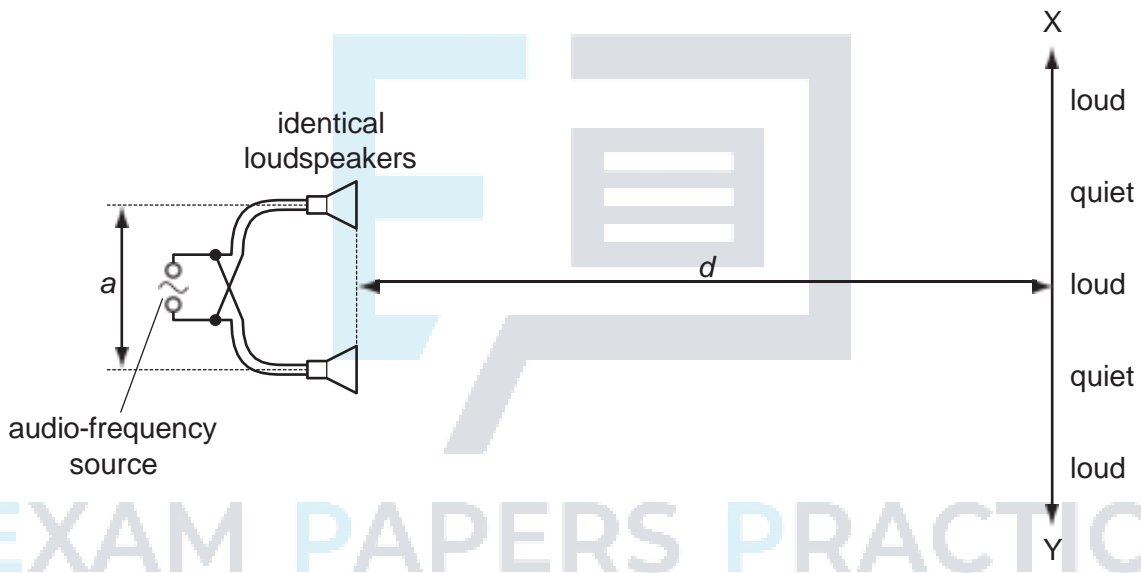

When a student moves along line XY , she notices that there are variations in the loudness of the sound. The regions in which the sound is heard are alternately loud and quiet as indicated on the diagram.

How may the distance between loud regions be reduced?

- A decreasing the distance a between the speakers
- B increasing distance d
- C increasing the frequency of the audio-frequency source
- D increasing the power output from the audio-frequency source

27. Monochromatic light of wavelength 690 nm passes through a diffraction grating with 300 lines per mm, producing a series of maxima on a screen.

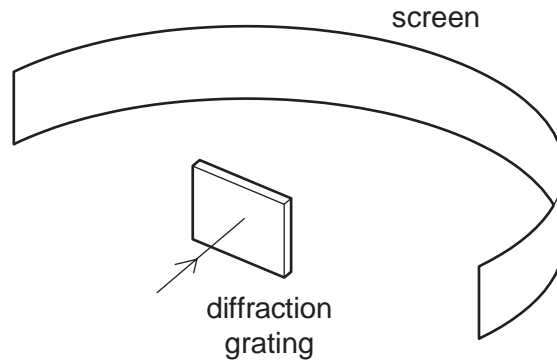

What is the greatest number of maxima that can be observed?

- A 4 B 5 C 8 D 9

28. Diffraction can be observed when a wave passes an obstruction. The diffraction effect is greatest when the wavelength and the obstruction are similar in size.

For waves travelling through air, what is the combination of wave and obstruction that could best demonstrate diffraction?

- A microwaves passing a steel post
B radio waves passing a copper wire
C sound waves passing a human hair
D visible light waves passing a gate post

29. A diffraction grating is used to measure the wavelength of monochromatic light, as shown in the diagram.

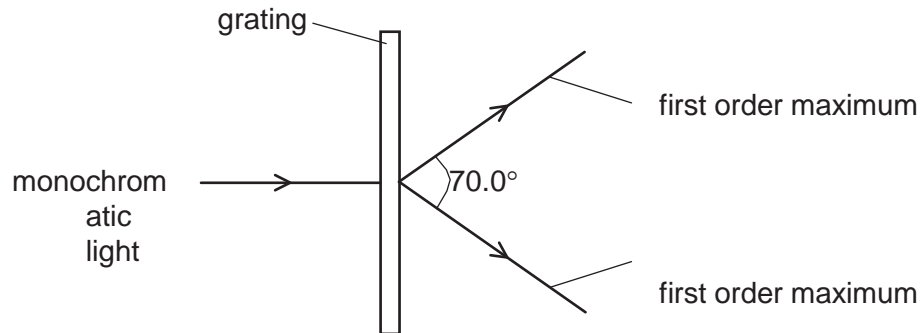

The spacing of the slits in the grating is 1.00×10^{-6} m. The angle between the first order diffraction maxima is 70.0° .

What is the wavelength of the light?

- A 287 nm B 470 nm C 574 nm D 940 nm

30. A monochromatic plane wave of speed c and wavelength λ is diffracted at a small aperture.

The diagram illustrates successive wavefronts.

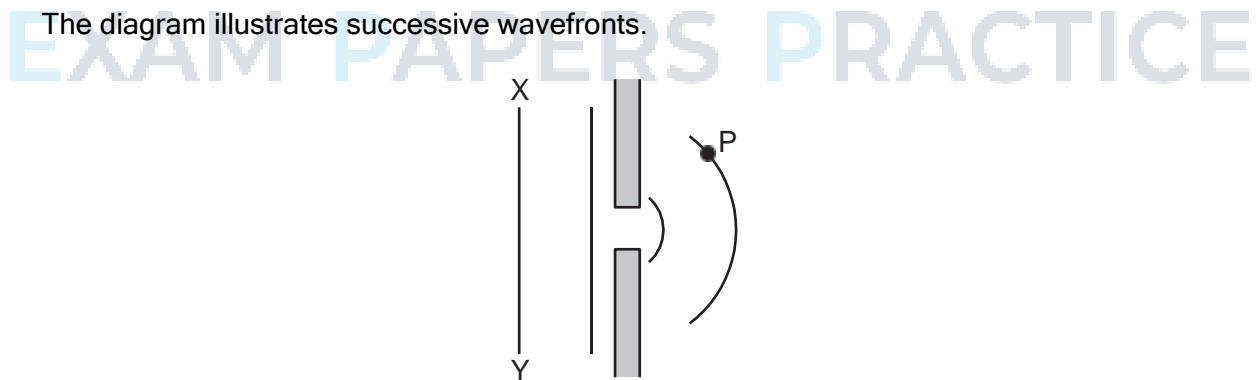

After what time will some portion of the wavefront XY reach point P?

- A. $\frac{3\lambda}{2c}$
 B. $\frac{2\lambda}{c}$

C. $\frac{3\lambda}{c}$

D. $\frac{4\lambda}{c}$

31. The diagram shows two tubes.

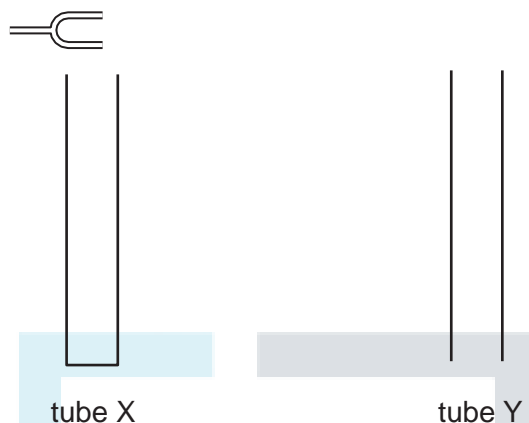

The tubes are identical except tube X is closed at its lower end while tube Y is open at its lower end. Both tubes have open upper ends.

A tuning fork placed above tube X causes resonance of the air at frequency f . No resonance is found at any lower frequency than f with tube X.

Which tuning fork will produce resonance when placed just above tube Y?

A a fork of frequency $\frac{f}{2}$

B a fork of frequency $\frac{2f}{3}$

C a fork of frequency $\frac{3f}{2}$

D a fork of frequency $2f$

32. A microwave transmitter emits waves towards a metal plate. The waves strike the plate and are reflected back along their original path.

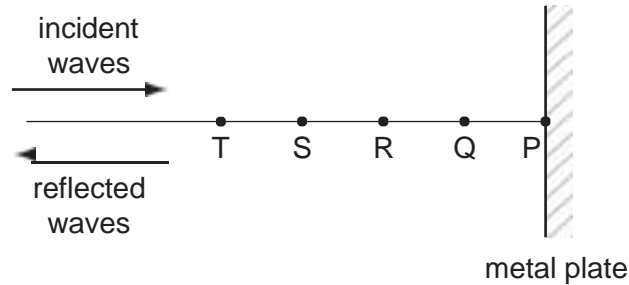

A microwave detector is moved along the line PT.

Points P, Q, R, S and T are the positions where minima of intensity are observed. These points are found to be 15 mm apart.

What is the frequency of the microwaves?

- A 5.0 GHz B 6.7 GHz C 10 GHz D 20 GHz

33. The diagram shows a steel wire clamped at one end and tensioned at the other by a weight hung over a pulley.

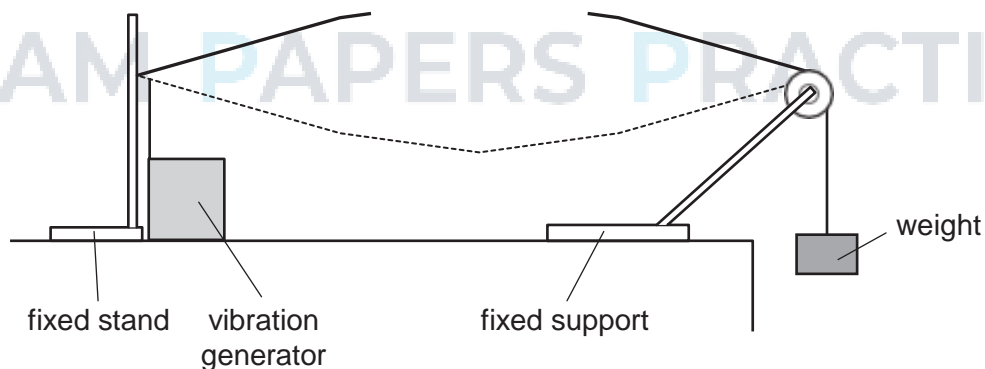

A vibration generator is attached to the wire near the clamped end. A stationary wave with one loop is produced. The frequency of the vibration generator is f .

Which frequency should be used to produce a stationary wave with two loops?

- A $\frac{f}{4}$ B $\frac{f}{2}$ C $2f$ D $4f$

34. The diagram shows a standing wave on a string. The standing wave has three nodes N_1 , N_2 and N_3 .

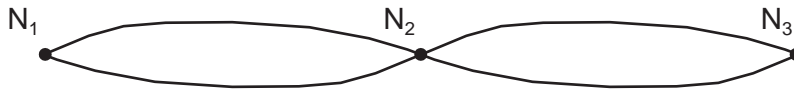

Which statement is correct?

- A All points on the string vibrate in phase.
- B All points on the string vibrate with the same amplitude.
- C Points equidistant from N_2 vibrate with the same frequency and in phase.
- D Points equidistant from N_2 vibrate with the same frequency and the same amplitude.

35. The diagram represents the pattern of stationary waves formed by the superposition of sound waves from a loudspeaker and their reflection from a metal sheet (not shown).

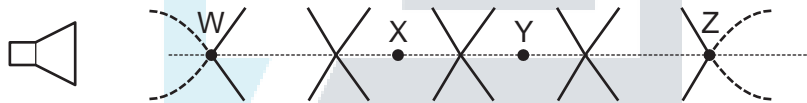

W, X, Y and Z are four points on the line through the centre of these waves. Which statement about these stationary waves is correct?

- A An antinode is formed at the surface of the metal sheet.
- B A node is a quarter of a wavelength from an adjacent antinode.
- C The oscillations at X are in phase with those at Y.
- D The stationary waves oscillate at right angles to the line WZ.

36. In which situation does diffraction occur?

- A A wave bounces back from a surface.
- B A wave passes from one medium into another.
- C A wave passes through an aperture.
- D Waves from two identical sources are superposed.

37. The diagrams show the arrangement of apparatus for a Young's slits experiment and also part of the pattern formed on the screen with a ruler placed next to it.

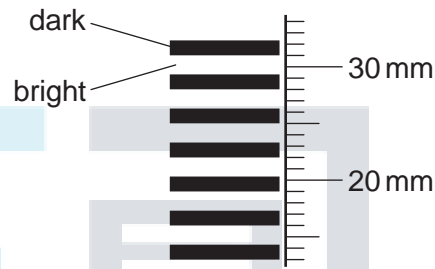
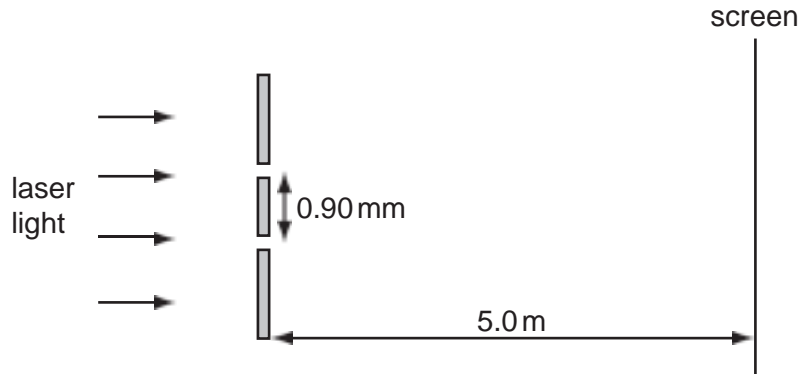

What is the wavelength of the light?

- A $4.8 \times 10^{-7} \text{ m}$ B $5.4 \times 10^{-7} \text{ m}$ C $3.2 \times 10^{-6} \text{ m}$ D $3.4 \times 10^{-6} \text{ m}$

38. A double slit experiment, using light of wavelength 600 nm, results in fringes being produced on a screen. The fringe separation is found to be 1.0 mm.

When the distance between the double slits and the viewing screen is increased by 2.0 m, the fringe separation increases to 3.0 mm.

What is the separation of the double slits producing the fringes?

- A 0.4 mm B 0.6 mm C 0.9 mm D 1.2 mm

39. Using monochromatic light, interference fringes are produced on a screen placed a distance D from a pair of slits of separation a . The separation of the fringes is x .

Both a and D are now doubled.

What is the new fringe separation?

- A $\frac{x}{2}$ B x C $2x$ D $4x$

40. Diagram 1 shows a ripple tank experiment in which plane waves are diffracted through a narrow slit in a metal sheet.

Diagram 2 shows the same tank with a slit of greater width.

In each case, the pattern of the waves incident on the slit and the emergent pattern are shown.

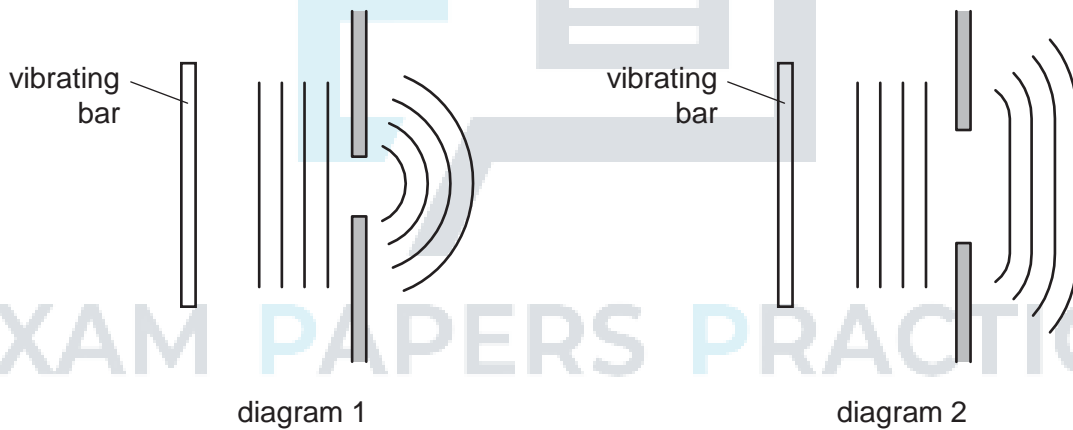

Which action would cause the waves in diagram 1 to be diffracted less and so produce an emergent pattern closer to that shown in diagram 2?

- A increasing the frequency of vibration of the bar
- B increasing the speed of the waves by making the water in the tank deeper
- C reducing the amplitude of vibration of the bar
- D reducing the length of the vibrating bar

41. What may be used to produce stationary waves?

- A blowing air over the top of an empty bottle
- B making a loud sound near a mountain
- C passing monochromatic light through a double slit
- D passing water waves through a narrow slit

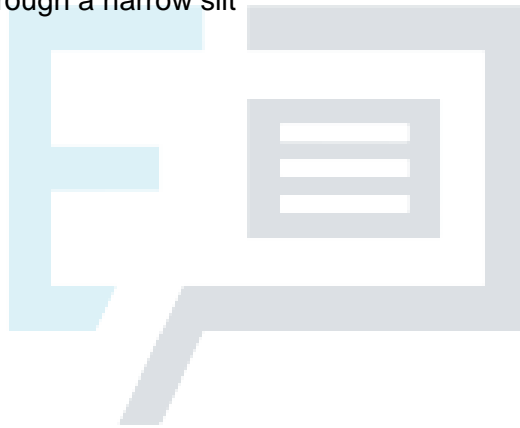

EXAM PAPERS PRACTICE

42. Where, in a standing wave, do the vibrations of the medium occur?
- A only at the nodes
 - B only at the antinodes
 - C at all points between the nodes
 - D at all points between the antinodes

43. The graph represents a standing wave at two different times.

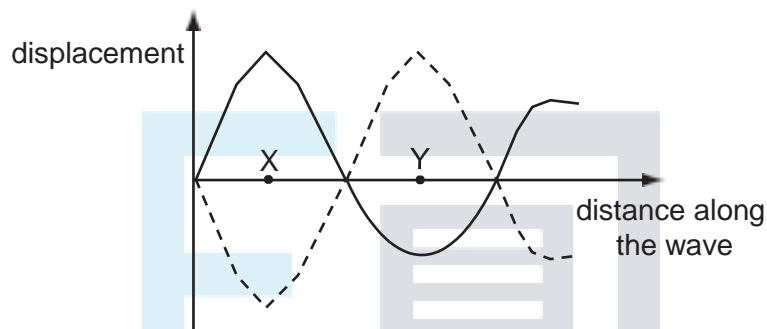

What does the distance XY represent?

- A half the amplitude
 - B half the frequency
 - C half the period
 - D half the wavelength
44. A sound wave is set up in a long tube, closed at one end. The length of the tube is adjusted until the sound from the tube is loudest.
- What is the nature of the sound wave in the tube?
- A longitudinal and progressive
 - B longitudinal and stationary
 - C transverse and progressive
 - D transverse and stationary

45. A stationary sound wave is set up along the line joining two loudspeakers.

Which measurement is sufficient on its own to enable you to deduce the wavelength of the wave?

- A the amplitude of the sound wave
- B the distance between the two loudspeakers
- C the distance between two adjacent antinodes
- D the frequency of the sound wave

46. Which of the following may be used to produce stationary waves?

- A blowing air over the top of an empty bottle
- B making a loud sound near a mountain
- C passing monochromatic light through a double slit
- D passing water waves through a narrow slit

47. In a double-slit experiment the distance between the fringes, on a screen, was too small to measure.

What would increase the distance between the fringes?

- a. increasing the distance between the light source and the slits
- b. increasing the distance between the slits and the screen
- c. increasing the distance between the slits
- d. increasing the frequency of the light source

48. Source S emits microwaves with a constant amplitude. The microwaves hit a metal screen P and are reflected. A stationary wave is formed between S and P. The wavelength of the microwaves is much smaller than the distance between S and P.

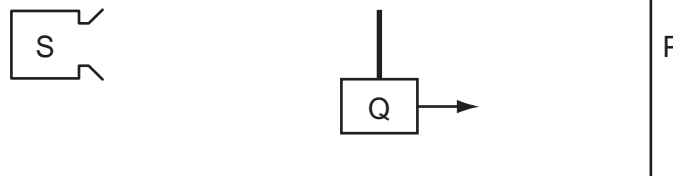

A detector Q is moved at a slow, constant speed from S to P.

What happens to the amplitude of the signal detected by Q?

- A decreases steadily
- B increases and decreases regularly
- C increases steadily
- D remains constant



EXAM PAPERS PRACTICE

49. A pattern of waves was observed without being able to view the source of the waves. The pattern is represented in the diagram.

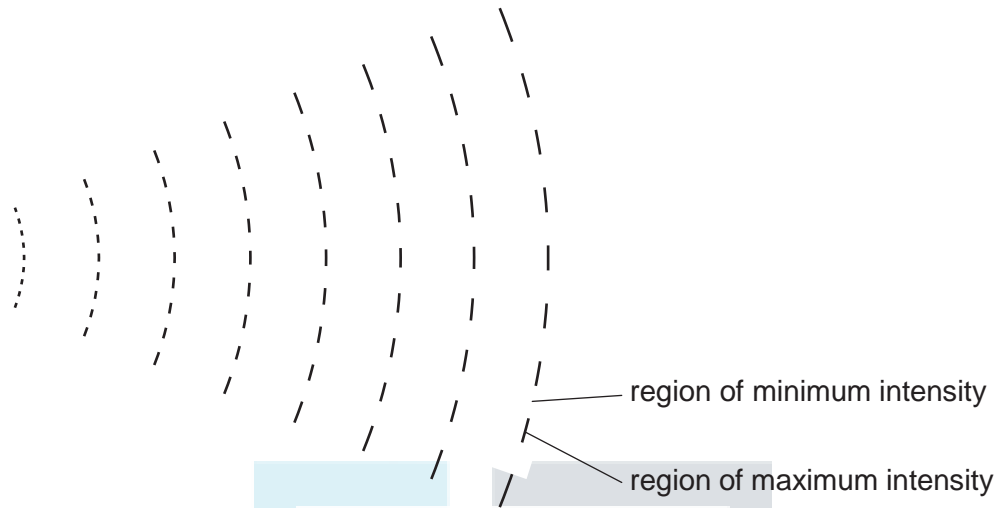

What can cause this pattern?

- A coherence only
- B diffraction and interference
- C diffraction only
- D interference only

50. Which electromagnetic wave would cause the most significant diffraction effect for an atomic lattice of spacing around 10^{-10} m?

- A infra-red
- B microwave
- C ultraviolet
- D X-ray

51. Wave generators at points X and Y produce water waves of the same wavelength. At point Z, the waves from X have the same amplitude as the waves from Y. Distances XZ and YZ are as shown.

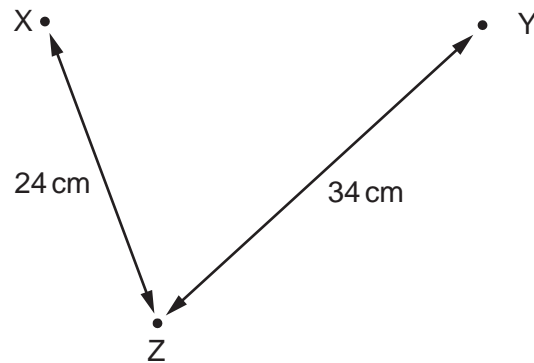

When the wave generators operate in phase, the amplitude of oscillation at Z is zero.

What could be the wavelength of the waves?

- A 2 cm B 3 cm C 4 cm D 6 cm

52. The diagram shows a stationary wave on a string at two instants of maximum vertical displacement.

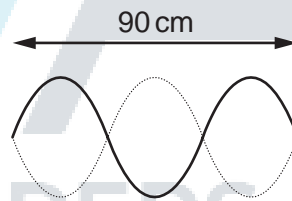

The frequency of the wave is 12 Hz.

What is the speed of the wave?

- A 3.6 m s^{-1} B 7.2 m s^{-1} C 360 m s^{-1} D 720 m s^{-1}

53. A loudspeaker emitting sound of frequency f is placed at the open end of a pipe of length l which is closed at the other end. A standing wave is set up in the pipe.

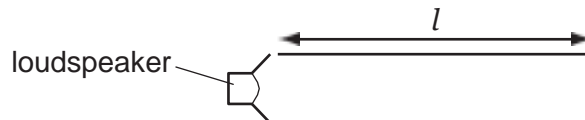

A series of pipes are then set up with either one or two loudspeakers of frequency f . The pairs of loudspeakers vibrate in phase with each other.

Which pipe contains a standing wave?

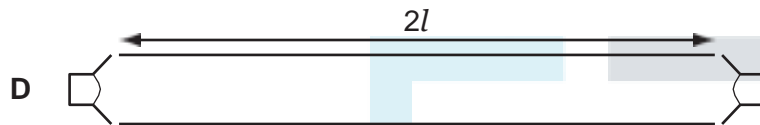
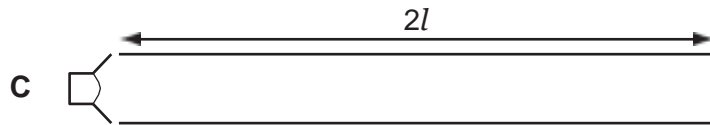
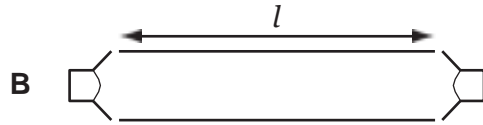
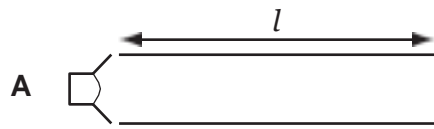

EXAM PAPERS PRACTICE

54. The table contains statements about stationary and progressive waves.

Which row is correct?

	stationary wave	progressive wave
A	all particles vibrate with the same amplitude	all particles vibrate with the same amplitude
B	energy is transferred along the wave	energy is transferred along the wave
C	particles in adjacent loops vibrate in antiphase	particles vibrate in phase with their immediate neighbours
D	particles one wavelength apart vibrate in phase	particles one wavelength apart vibrate in phase

55. A stationary sound wave is produced in a tube.

Which statement describes the wave speed?

- It is the distance between two adjacent nodes divided by the period of the wave.
- It is the speed at which energy is transferred from one antinode to an adjacent antinode.
- It is the speed of a particle at an antinode.
- It is the speed of one of the progressive waves that are producing the stationary wave.

56. Monochromatic light is incident on a diffraction grating and a diffraction pattern is observed.

Which line of the table gives the effect of replacing the grating with one that has more lines per metre?

	number of orders of diffraction visible	angle between first and second orders of diffraction
A	decreases	decreases
B	decreases	increases
C	increases	decreases
D	increases	increases

57. Light of wavelength λ passes through a diffraction grating with slit spacing d . A series of lines is observed on a screen.

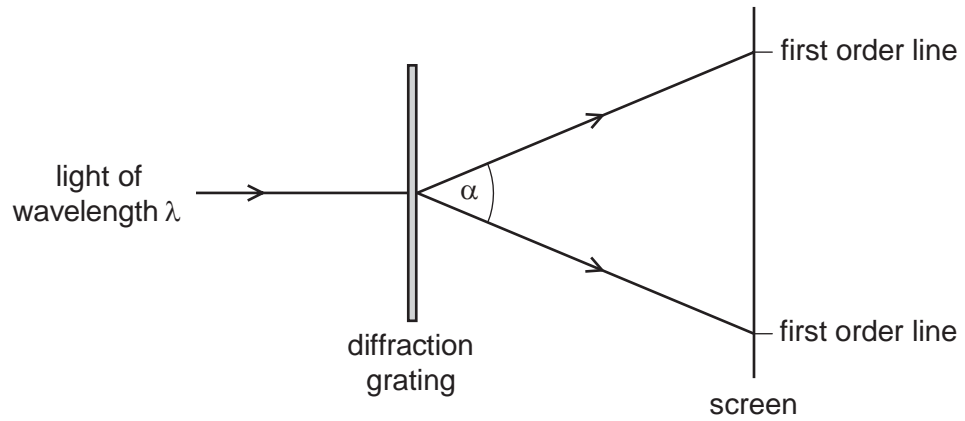

What is the angle α between the two first order lines?

- A $\sin^{-1} \frac{\lambda}{2d}$ B $\sin^{-1} \frac{\lambda}{d}$ C $2 \sin^{-1} \frac{\lambda}{d}$ D $2 \sin^{-1} \frac{\lambda}{2d}$

58. A student connects two loudspeakers to a signal generator.

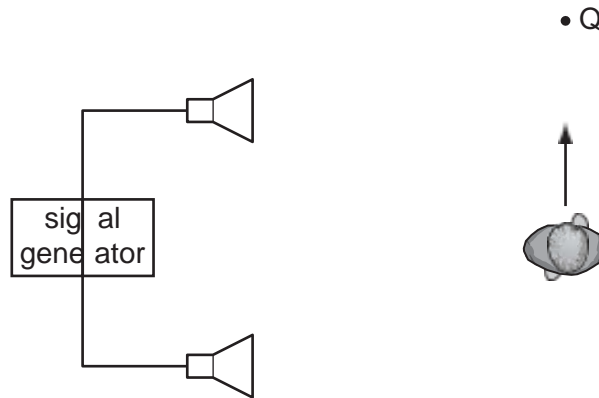

As the student walks from P to Q, he notices that the loudness of the sound rises and falls repeatedly.

What causes the loudness of the sound to vary?

- A diffraction of the sound waves
- B interference of the sound waves
- C polarisation of the sound waves
- D reflection of the sound waves

EXAM PAPERS PRACTICE

59. What is meant by diffraction?

- A Addition of two coherent waves to produce a stationary wave pattern.
- B Bending of waves round an obstacle.
- C Change of direction when waves cross the boundary between one medium and another.
- D Splitting of white light into colours.

60. Light of wavelength 700 nm is incident on a pair of slits, forming fringes 3.0 mm apart on a screen.

What is the fringe spacing when light of wavelength 350 nm is used and the slit separation is doubled?

- A 0.75 mm B 1.5 mm C 3.0 mm D 6.0 mm



EXAM PAPERS PRACTICE