



1.

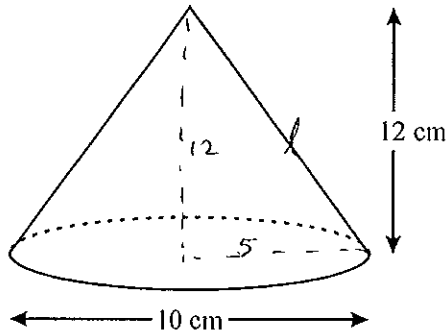

Diagram NOT accurately drawn

The diagram represents a cone.  
The height of the cone is 12 cm.  
The diameter of the base of the cone is 10 cm.

Calculate the curved surface area of the cone.  
Give your answer as a multiple of  $\pi$ .

$$\text{curved surface area} = \pi r l$$

$$l = \sqrt{12^2 + 5^2} = 13$$

$$r = 5$$

$$\begin{aligned} \text{curved surface area} &= \pi (5)(13) \\ &= \underline{\underline{65\pi}} \end{aligned}$$

$$\dots 65\pi \dots \text{cm}^2$$

(Total 3 marks)



2.

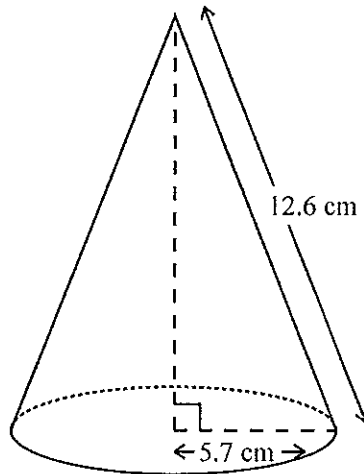

Diagram NOT accurately drawn

The radius of the base of a cone is 5.7 cm.  
Its slant height is 12.6 cm.

Calculate the volume of the cone.  
Give your answer correct to 3 significant figures.

$$\text{Volume of cone} = \frac{1}{3} \pi r^2 h$$

$$r = 5.7$$

$$h = \sqrt{12.6^2 - 5.7^2}$$

$$= 11.23699248$$

$$\text{Volume of cone} = \frac{1}{3} \pi (5.7)^2 (11.23699248)$$

$$= 382.3212343$$

$$= 382 \text{ cm}^3 \text{ (3sf)}$$

..... 382 ..... cm<sup>3</sup>

(Total 4 marks)

3.

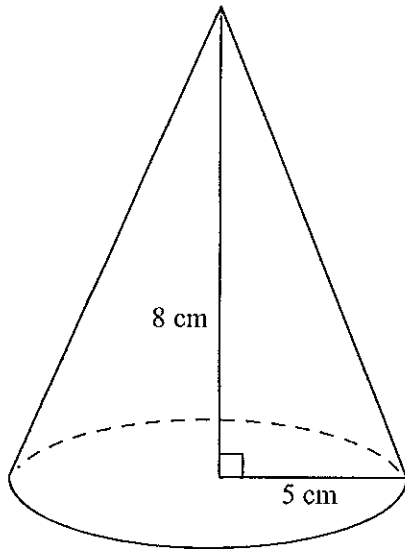

Diagram NOT  
accurately drawn

A cone has a base radius of 5 cm and a vertical height of 8 cm.

Calculate the volume of the cone.

Give your answer correct to 3 significant figures.

$$\begin{aligned}\text{Volume} &= \frac{1}{3} \pi r^2 h \\ &= \frac{1}{3} (\pi) (5)^2 (8) \\ &= 209.4395102 \text{ cm}^3 \\ &= 209 \text{ cm}^3 \text{ (3sf)}\end{aligned}$$

.....209..... cm<sup>3</sup>

(2)

4. The diagram shows a child's toy.

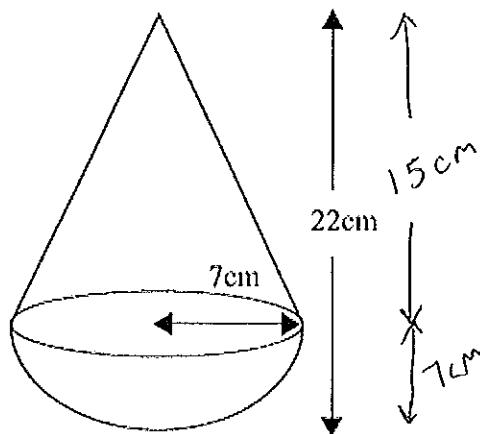

Diagram **NOT** accurately drawn

The toy is made from a cone on top of a hemisphere. The cone and hemisphere each have radius 7 cm. The total height of the toy is 22 cm. Work out the volume of the toy. Give your answer correct to 3 significant figures.

$$\text{volume of cone} = \frac{1}{3} \pi r^2 h$$

$$\text{volume of hemisphere} = \frac{1}{2} \left( \frac{4}{3} \pi r^3 \right)$$

$$\text{total volume} = \frac{1}{3} \pi (7)^2 (15) + \frac{4^2}{6^3} \pi (7)^3$$

$$= 1488.06772$$

$$= 1490 \text{ 3sf}$$

..... 1490 ..... cm<sup>3</sup>  
 (Total 3 marks)



5. The diagram shows a solid hemisphere of radius 8 cm.

Diagram NOT  
accurately drawn

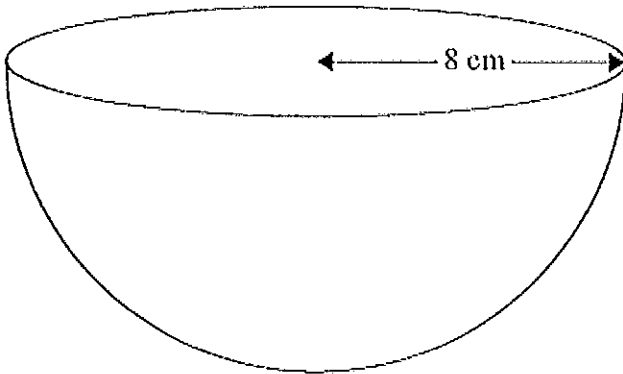

Work out the total surface area of the hemisphere.  
Give your answer correct to 3 significant figures.

$$\begin{aligned} \text{Surface area of hemisphere} &= \pi r^2 + 2\pi r^2 \\ &= 3\pi r^2 \\ &= 3(\pi)(8)^2 \\ &= 603.1857895 \text{ cm}^2 \\ &= 603 \text{ cm}^2 \text{ (3 SF)} \end{aligned}$$

$\frac{1}{2}(4\pi r^2)$   
↓

.....603..... cm<sup>2</sup>

(Total 3 marks)

6.

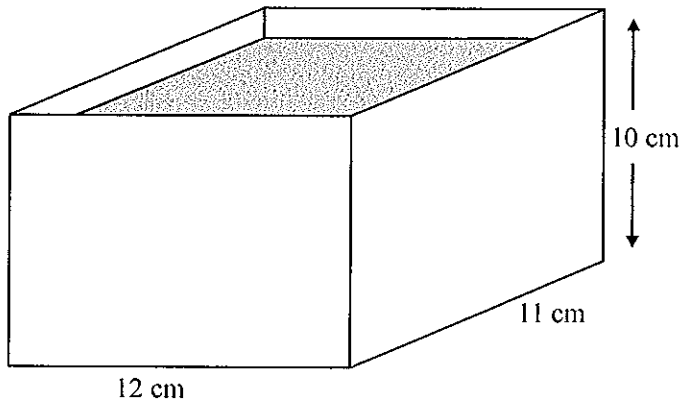
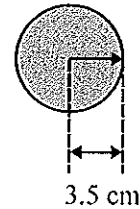

Diagram NOT accurately drawn



A rectangular container is 12 cm long, 11 cm wide and 10 cm high. The container is filled with water to a depth of 8 cm.

A metal sphere of radius 3.5 cm is placed in the water. It sinks to the bottom.

Calculate the rise in the water level.  
Give your answer correct to 3 significant figures.

$$\begin{aligned} \text{Initial volume} &= 12 \times 11 \times 8 \\ &= 1056 \text{ cm}^3 \end{aligned}$$

$$\begin{aligned} \text{Volume of sphere} &= \frac{4}{3} \pi r^3 \\ &= \frac{4}{3} (\pi) (3.5)^3 \\ &= 179.59438 \end{aligned}$$

$$\text{New volume} = 1056 + 179.59438 = 1235.59438 \text{ cm}^3$$

$$\begin{aligned} 12 \times 11 \times h &= 1235.59438 \\ h &= 9.360563485 \text{ cm} \end{aligned}$$

$$\begin{aligned} \text{Rise} &= 9.360563485 - 8 \\ &= 1.360563485 \\ &= 1.36 \text{ cm (3sf)} \end{aligned}$$

.....1.36.....cm  
(Total 4 marks)

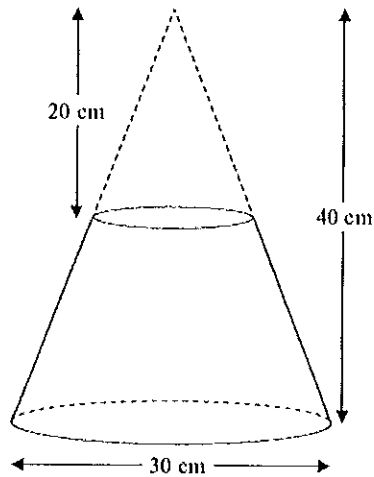

7.

Diagram NOT  
accurately drawn

A frustum is made by removing a small cone from a similar large cone.

The height of the small cone is 20 cm.

The height of the large cone is 40 cm.

The diameter of the base of the large cone is 30 cm.

Work out the volume of the frustum.

Give your answer correct to 3 significant figures.

$$\text{Big cone volume} = \frac{1}{3} (\pi) (15)^2 (40)$$

$$\text{Small cone volume} = \frac{1}{3} (\pi) (7.5)^2 (20)$$

↑  
(half 15)  
Similar shapes

$$\begin{aligned} \text{Frustum volume} &= \frac{1}{3} (\pi) (15)^2 (40) - \frac{1}{3} (\pi) (7.5)^2 (20) \\ &= 8246.680716 \text{ cm}^3 \\ &= 8250 \text{ cm}^3 \end{aligned}$$

.....8250..... cm<sup>3</sup>

(Total 4 marks)