

# Mechanics

## (Motion Graphs)

### TOPIC QUESTIONS (2)

<b>Level</b>	<b>A Level</b>
<b>Subject</b>	<b>Physics</b>
<b>Exam Board</b>	<b>CIE</b>
<b>Paper Type</b>	<b>Multiple Choice</b>

Time Allowed : 1Hour 20 Min

EXAM PAPERS PRACTICE

1. A car at rest in a traffic queue moves forward in a straight line and then comes to rest again. The graph shows the variation with time of its displacement.

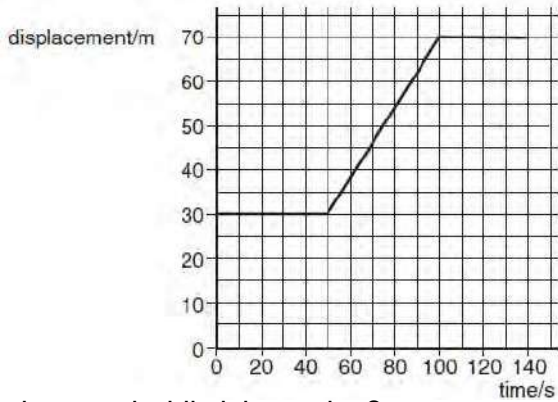

What is its speed while it is moving?

- A  $0.70\text{ms}^{-1}$     B  $0.80\text{ms}^{-1}$     C  $1.25\text{ms}^{-1}$     D  $1.40\text{ms}^{-1}$

2. Following is the velocity time curve.

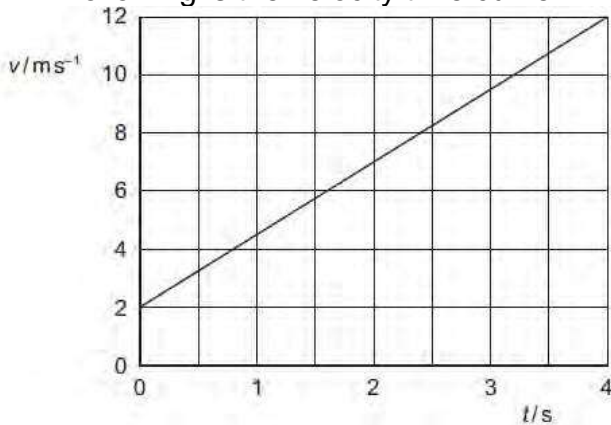

What is the distance travelled between time  $t = 0$  and  $t = 4$  s?

- A 2.5 m    B 3.0 m    C 20 m    D 28 m

3. The velocity of an object during the first five seconds of its motion is shown on the graph.

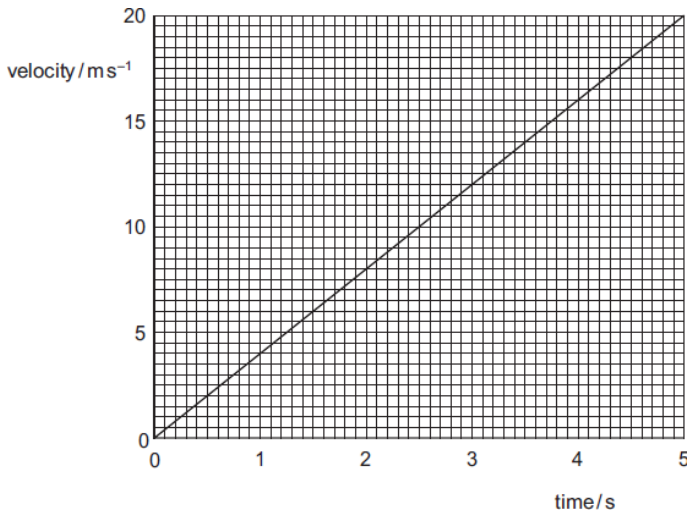

What is the distance travelled by the object in this time?

- A 4 m    B 20 m    C 50 m    D 100 m

4. The graph shows velocity-time plots for two vehicles X and Y. The accelerations and distances traveled by the two vehicles can be estimated from these plots.

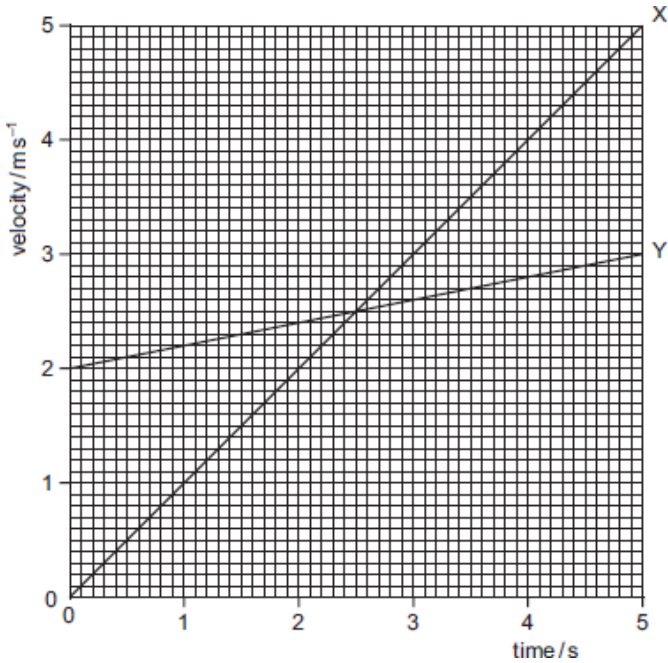

Which statement is correct?

- A The accelerations of X and Y are the same at 2.5 s.
- B The initial acceleration of Y is greater than that of X.
- C The distance travelled by X is greater than that travelled by Y in the 5 s period.
- D The distances travelled by X and Y in the 5 s period are the same

5. The diagram shows a velocity-time graph.

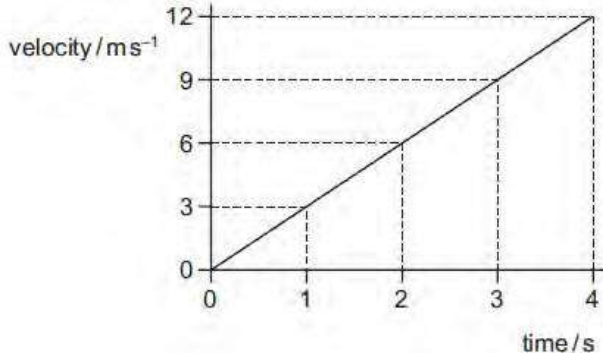

What is the displacement during the last 2 seconds of the motion?

- A 6 m
- B 12 m
- C 18 m
- D 24 m

6. A ball is released from rest above a horizontal surface. The graph shows the variation with time of its velocity.

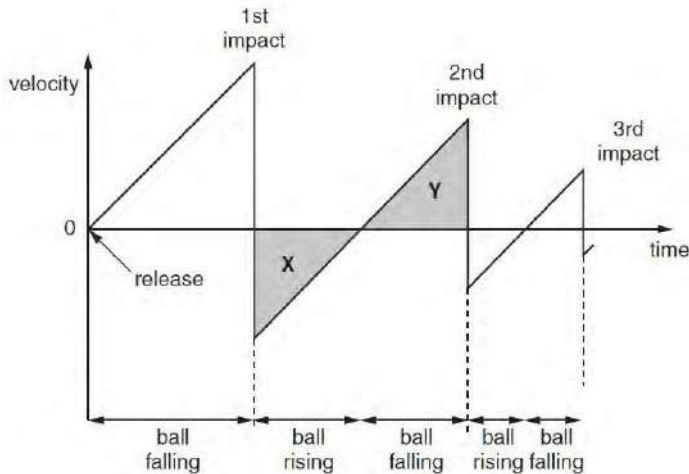

Areas X and Y are equal. This is because

- A** the ball's acceleration is the same during its upward and downward motion.
- B** the speed at which the ball leaves the surface after an impact is equal to the speed at which it returns to the surface for the next impact.
- C** for one impact, the speed at which the ball hits the surface equals the speed at which it leaves the surface.
- D** the ball rises and falls through the same distance between impacts.

7. A ball is released from rest above a horizontal surface and bounces several times. The graph shows how, for this ball, a quantity  $y$  varies with time.

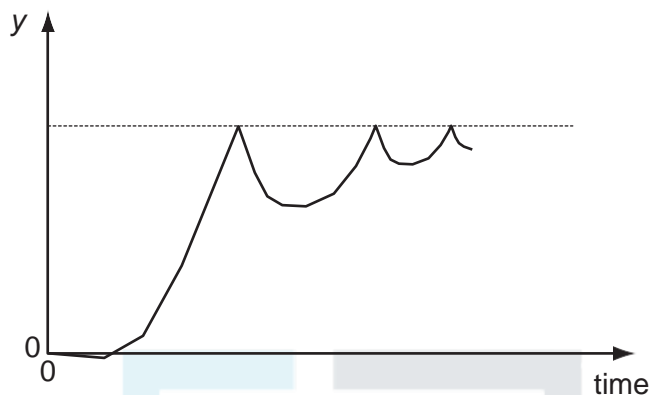

What is the quantity  $y$ ?

- A acceleration
- B displacement
- C kinetic energy
- D velocity

EXAM PAPERS PRACTICE

8. The diagram shows a velocity-time graph.

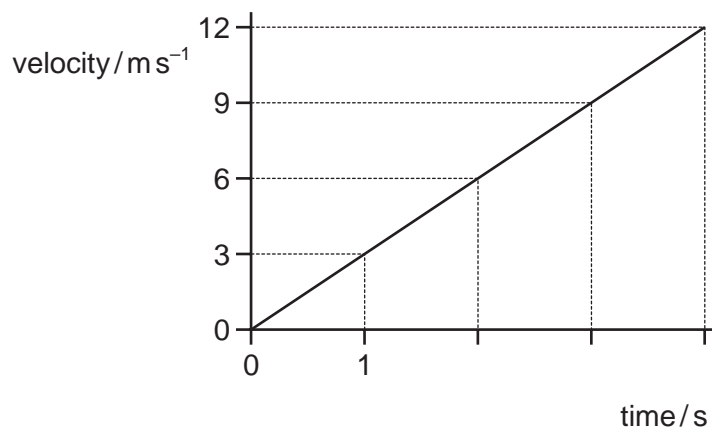

What is the displacement during the last 2 seconds of the motion?

- A 6 m
- B 12 m
- C 18 m
- D 24 m

9. Which displacement-time graph best represents the motion of a falling sphere, the initial acceleration of which eventually reduces until it begins to travel at constant terminal velocity?

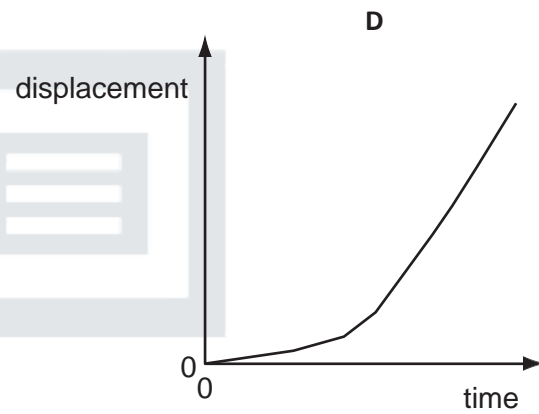
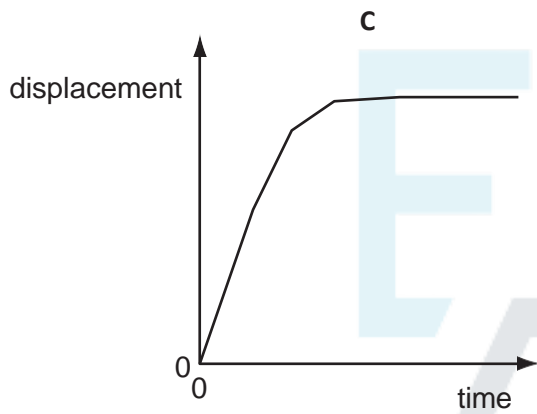
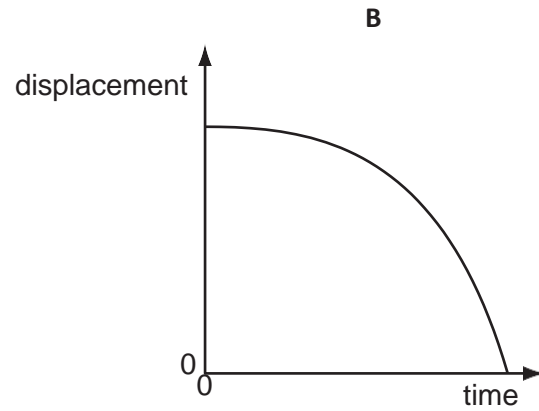
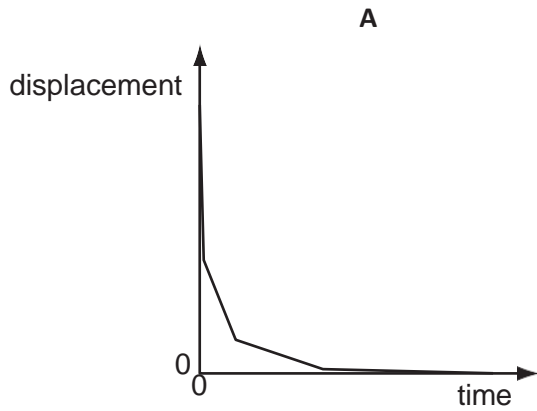

EXAM PAPERS PRACTICE

10. When a car driver sees a hazard ahead, she applies the brakes as soon as she can and brings the car to rest.

The graph shows how the speed  $v$  of the car varies with time  $t$  after she sees the hazard.

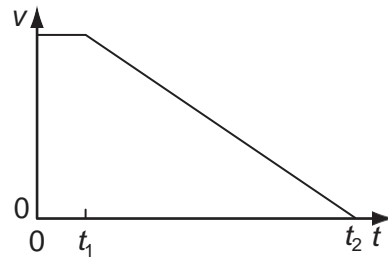

Which graph represents the variation with time  $t$  of the distance  $s$  travelled by the car after she has seen the hazard?

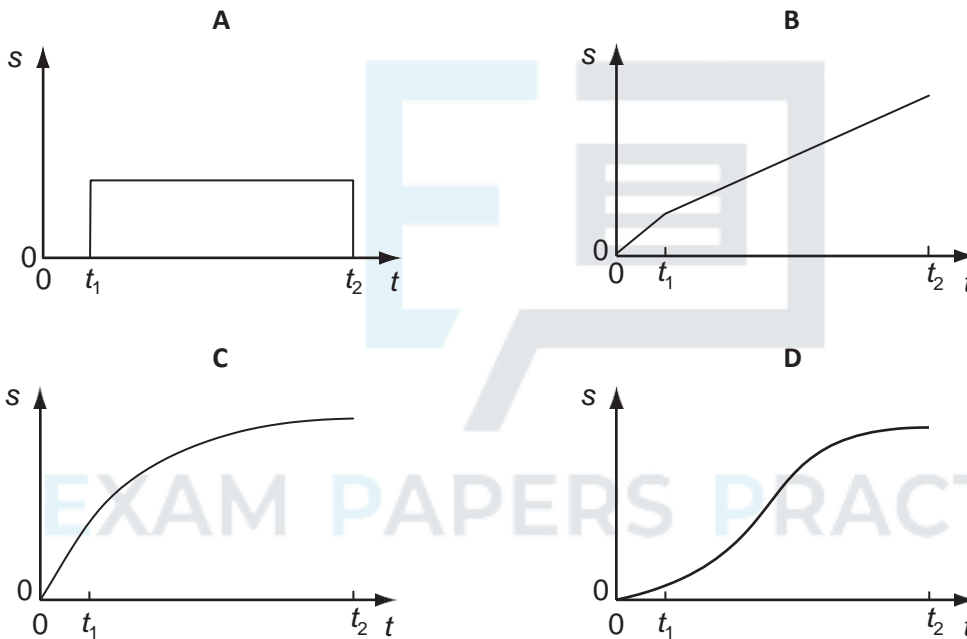

11. The diagram shows a velocity-time graph for a car.

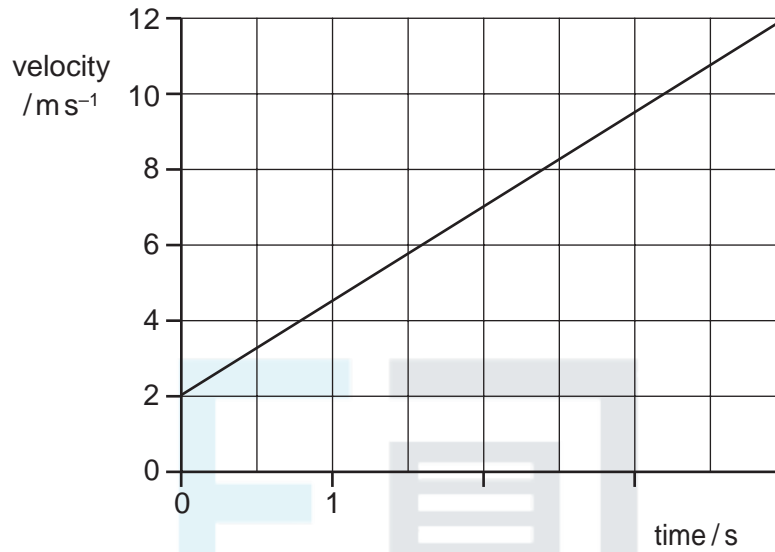

What is the distance travelled during the first 4.0 s?

- A 2.5 m      B 3.0 m      C 20 m      D 28 m

12. Which graph represents the motion of a car that is travelling along a straight road with a speed that increases uniformly with time?

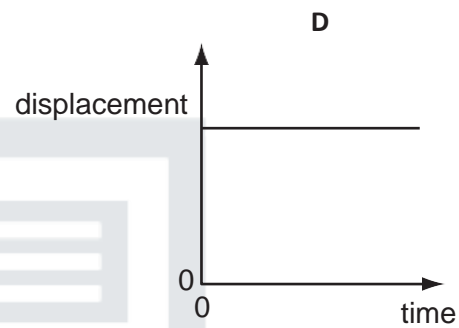
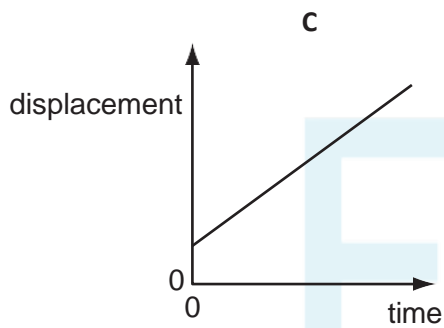
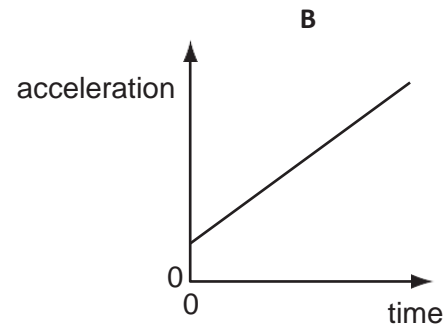
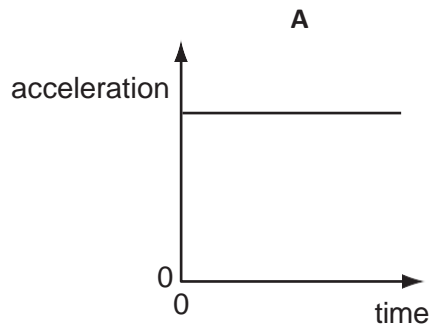



13. A football is dropped from the top of a tall building.

Which acceleration-time graph best represents the motion of the football through the air?

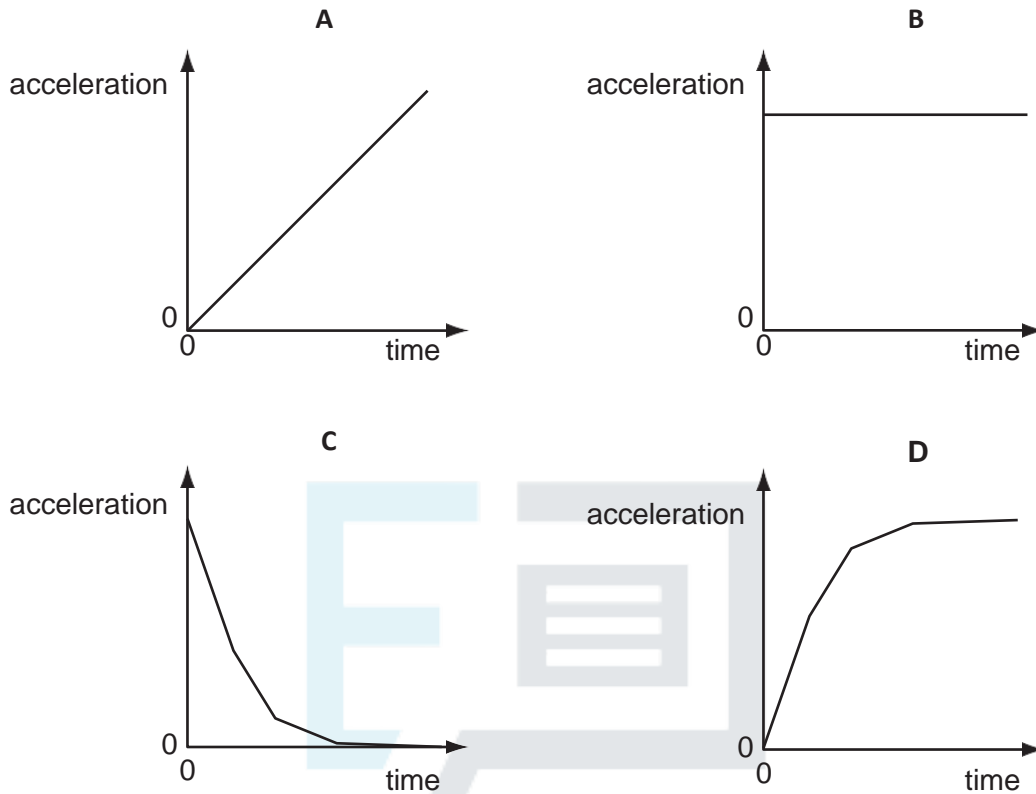

14. A particle moves along a straight line. A particular property  $K$  of the particle's motion is plotted against time.

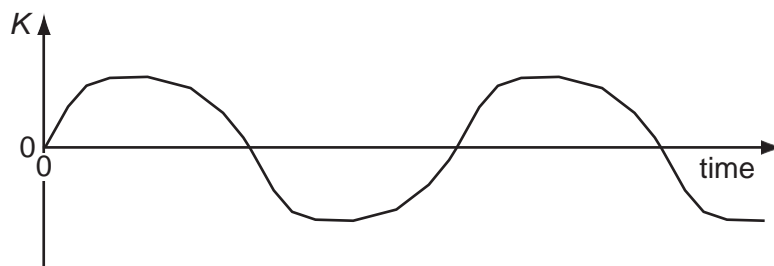

At any time, the slope of the graph is the acceleration of the particle.

What is the property  $K$ ?

- A the displacement of the particle
- B the distance travelled by the particle
- C the speed of the particle
- D the velocity of the particle

15. A stone is thrown vertically upwards. A student plots the variation with time of its velocity.

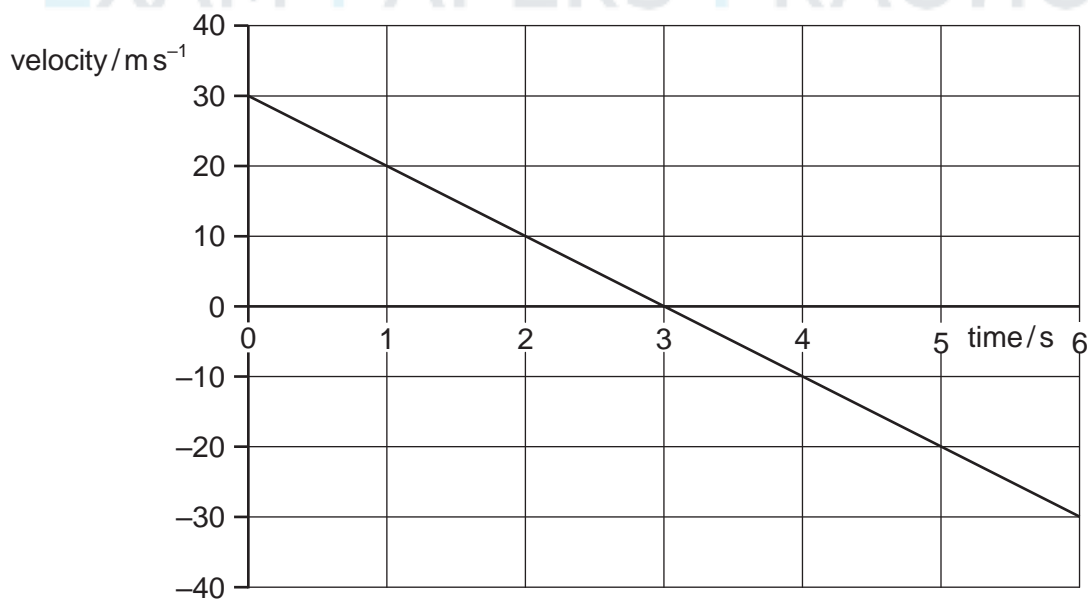

What is the vertical displacement of the stone from its starting point after 5 seconds?

- A 20 m
- B 25 m
- C 45 m
- D 65 m

16. The graph shows how a certain quantity  $p$  varies with another quantity  $q$  for a parachutist falling at terminal speed.

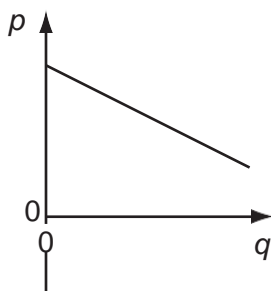

What are the quantities  $p$  and  $q$ , and what is represented by the magnitude of the gradient of the graph?

	quantity $p$	quantity $q$	magnitude of gradient
A	height	time	terminal speed
B	momentum	time	weight of parachutist
C	height	potential energy	mass of parachutist
D	velocity	time	acceleration of free fall

17. The graph relates to the motion of a falling body.

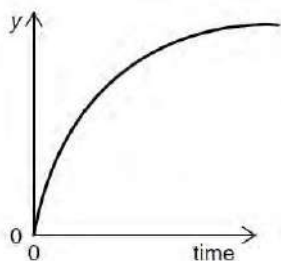

Which is a correct description of the graph?

- A  $y$  is distance and air resistance is negligible
- B  $y$  is distance and air resistance is not negligible
- C  $y$  is speed and air resistance is negligible
- D  $y$  is speed and air resistance is not negligible

18. Which graph represents the motion of a car that is travelling along a straight road with a uniformly increasing speed?

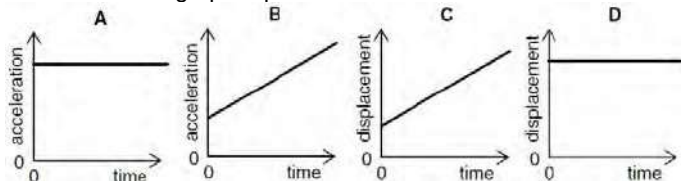

19. A stone is thrown upwards from the top of a cliff. After reaching its maximum height, it falls past the cliff-top and into the sea. The graph shows how the vertical velocity  $v$  of the stone varies with time  $t$  after being thrown upwards.  $R$  and  $S$  are the magnitudes of the areas of the two triangles.

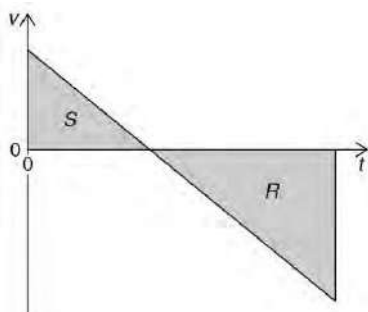

What is the height of the cliff-top above the sea?  
**A**  $R$       **B**  $S$       **C**  $R + S$       **D**  $R - S$

**Nov 02**

20. A particle is moving in a straight line with uniform acceleration.  
 Which graph represents the motion of the particle?

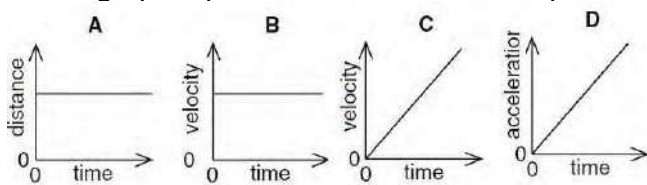

21. A projectile is launched at point O and follows the path OPQRS, as shown. Air resistance may be neglected.

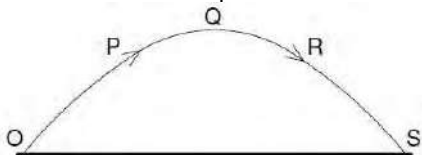

Which statement is true for the projectile when it is at the highest point Q of its path?

- A** The horizontal component of the projectile's acceleration is zero.
- B** The horizontal component of the projectile's velocity is zero.
- C** The kinetic energy of the projectile is zero.
- D** The momentum of the projectile is zero.

22. Two markers M1 and M2 are set up a vertical distance  $h$  apart.

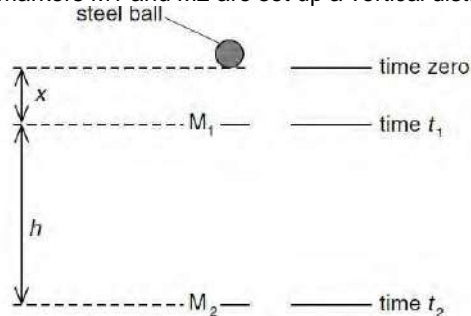

When a steel ball is released from rest from a point a distance  $x$  above M1, it is found that the ball takes time  $t_1$  to reach M1 and time  $t_2$  to reach M2. Which expression gives the acceleration of the ball?

- A**  $\frac{2h}{t_2^2}$     **B**  $\frac{2h}{(t_2 + t_1)}$     **C**  $\frac{2h}{(t_2 - t_1)^2}$     **D**  $\frac{2h}{(t_2^2 - t_1^2)}$

23. A body falls from rest in a vacuum near the Earth's surface. The variation with time  $t$  of its speed  $v$  is shown below.

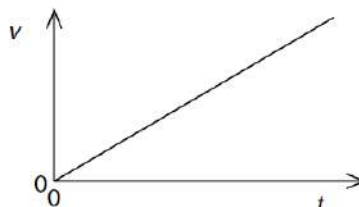

Which graph shows the variation with time  $t$  of the speed  $v$  of the same ball falling in air at the same place on Earth?

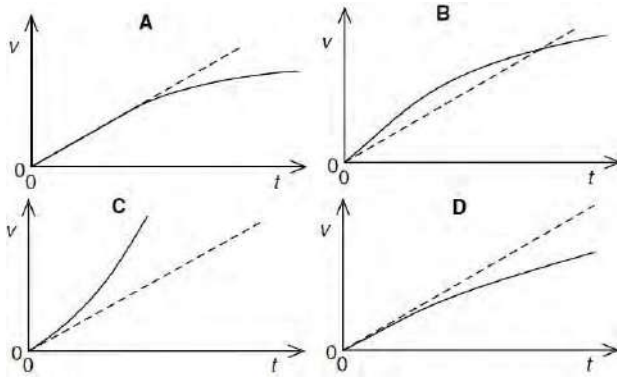
**June 03**

24. Which of the following is a scalar quantity?

**A** acceleration   **B** mass   **C** momentum   **D** velocity

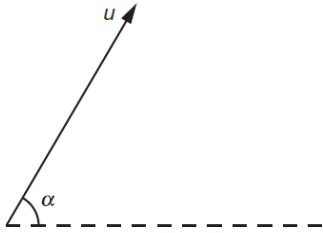
 25. A projectile is fired at an angle  $\alpha$  to the horizontal at a speed  $u$ , as shown.

 What will be the vertical and horizontal components of its velocity after a time  $t$ ? Assume that air resistance is negligible. The acceleration of free fall is  $g$ .

	vertical component	horizontal component
<b>A</b>	$u \sin \alpha$	$u \cos \alpha$
<b>B</b>	$u \sin \alpha - gt$	$u \cos \alpha - gt$
<b>C</b>	$u \sin \alpha - gt$	$u \cos \alpha$
<b>D</b>	$u \cos \alpha$	$u \sin \alpha - gt$

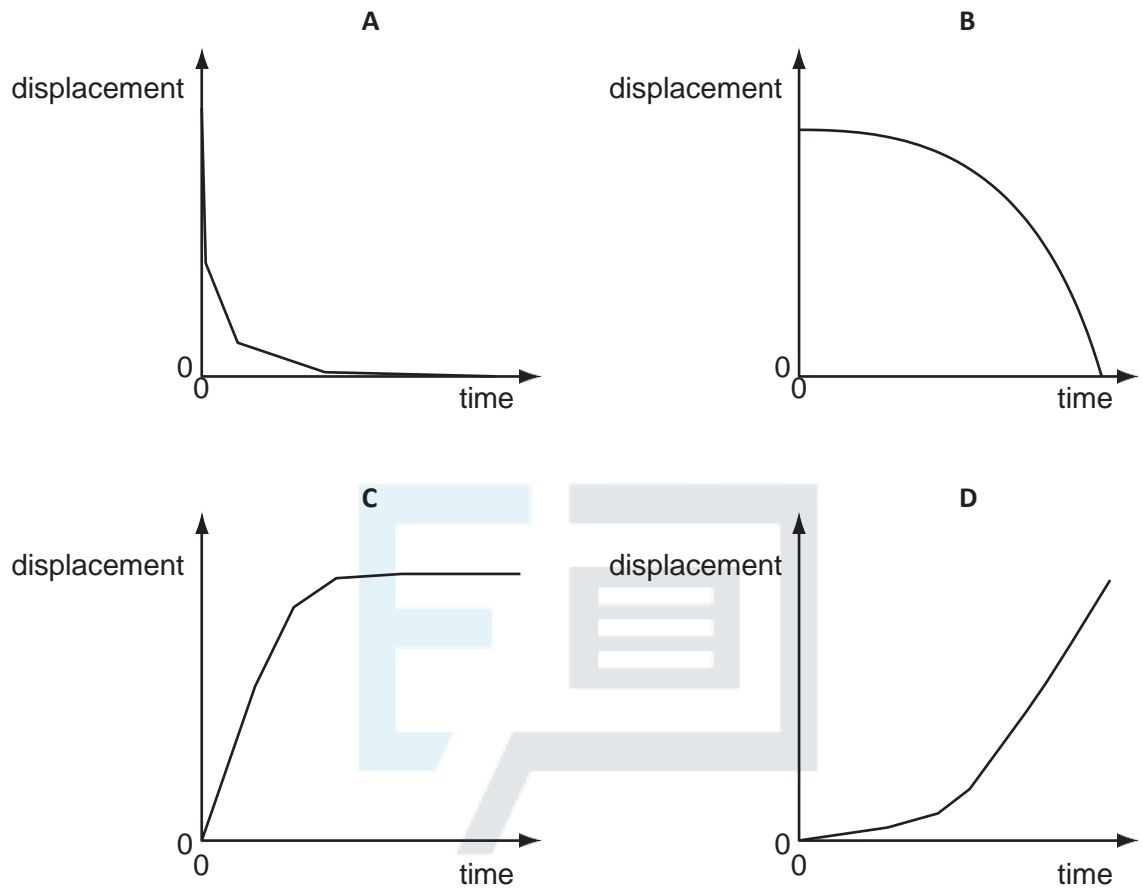
26. A sphere is released and falls. Its initial acceleration reduces until it eventually begins to travel at constant terminal velocity. Which displacement-time graph best represents the motion of the sphere?



EXAM PAPERS PRACTICE

27. A stone is thrown horizontally from the top of a cliff. Air resistance is negligible.

Which graph shows the variation with time of the vertical component of the stone's velocity?

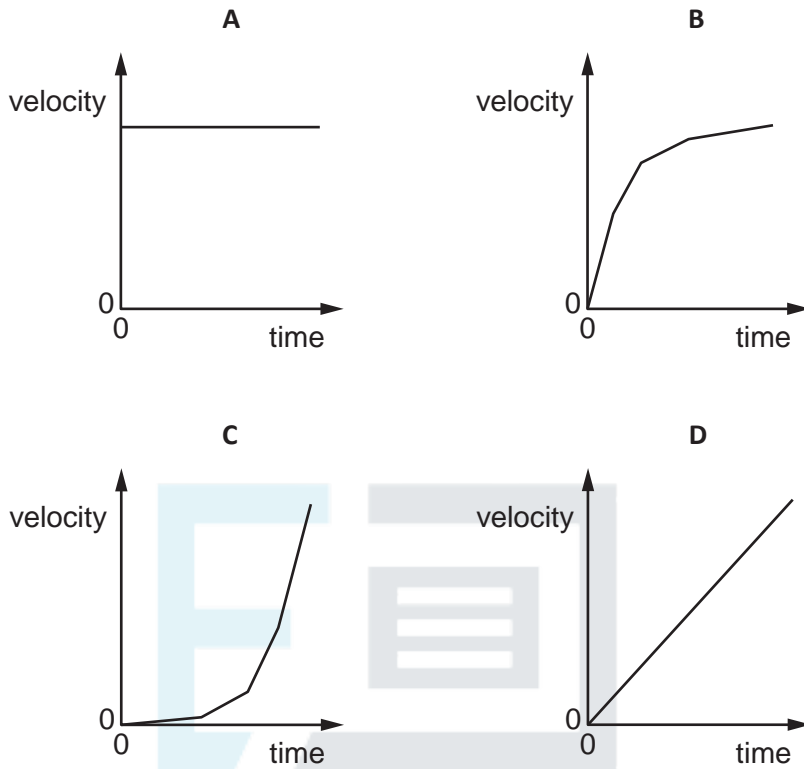

28. A raindrop falls vertically from rest in air. The variation with time of the speed of the raindrop is shown in the graph.

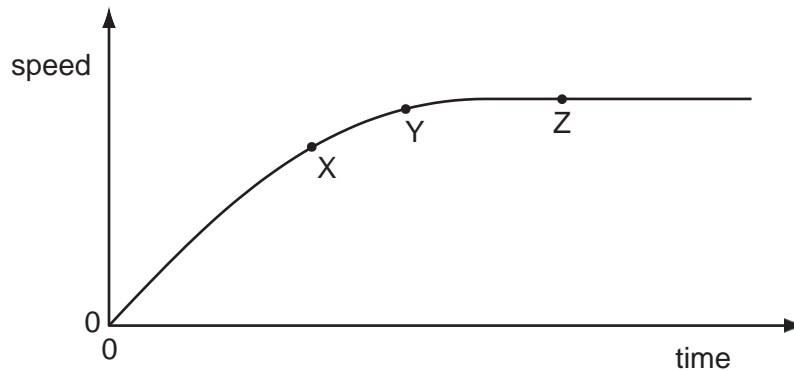

Which statement about the raindrop is correct?

- A At point X, the raindrop has an acceleration of  $9.81 \text{ m s}^{-2}$ .
- B At point Z, the force on the raindrop due to air resistance has reached its maximum value and so the acceleration of the raindrop has also reached its maximum value.
- C At point Z, the force due to air resistance is equal and opposite to the weight of the raindrop and so the speed of the raindrop is zero.
- D The resultant force on the raindrop at point Y is less than the resultant force on the raindrop at point X.

29. The velocity of an electric car changes as shown.

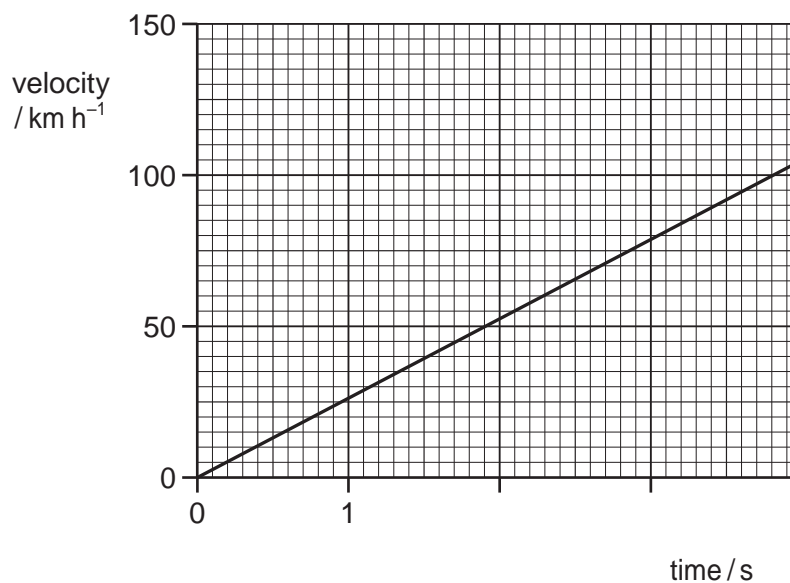

What is the acceleration of the car?

- A  $210 \text{ m s}^{-2}$
- B  $58 \text{ m s}^{-2}$
- C  $26 \text{ m s}^{-2}$
- D  $7.3 \text{ m s}^{-2}$



30. Which graph represents the motion of a car that is travelling along a straight road with a speed that increases uniformly with time?

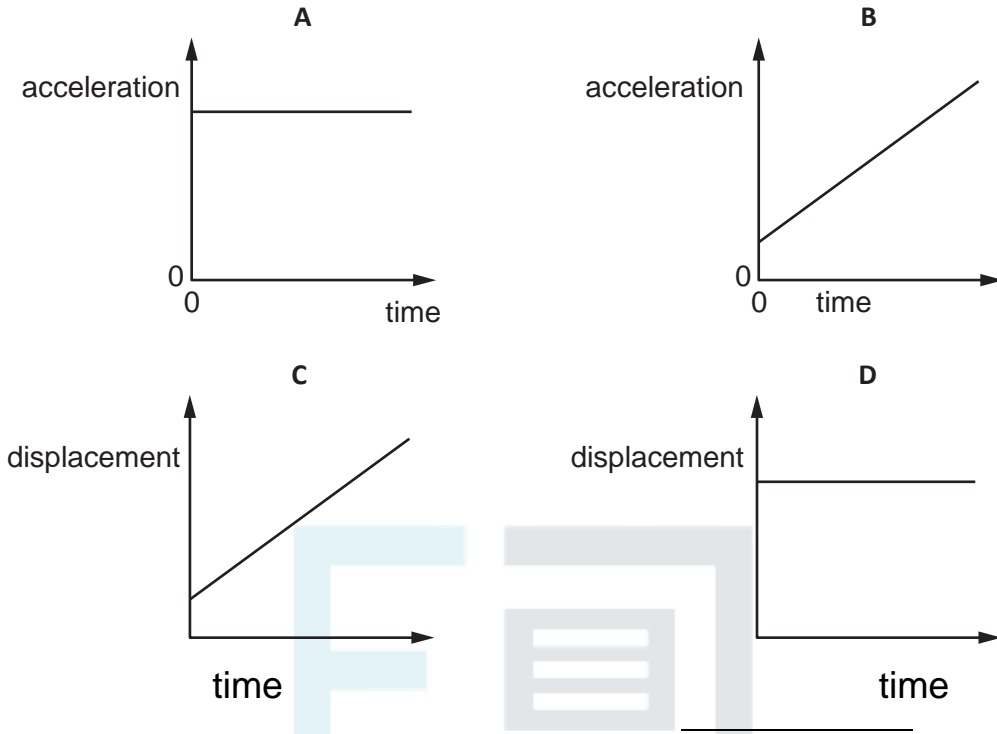

31. A tennis ball is dropped onto a table and bounces back up. The table exerts a force  $F$  on the ball. Which graph best shows the variation with time  $t$  of the force  $F$  while the ball is in contact with the table?

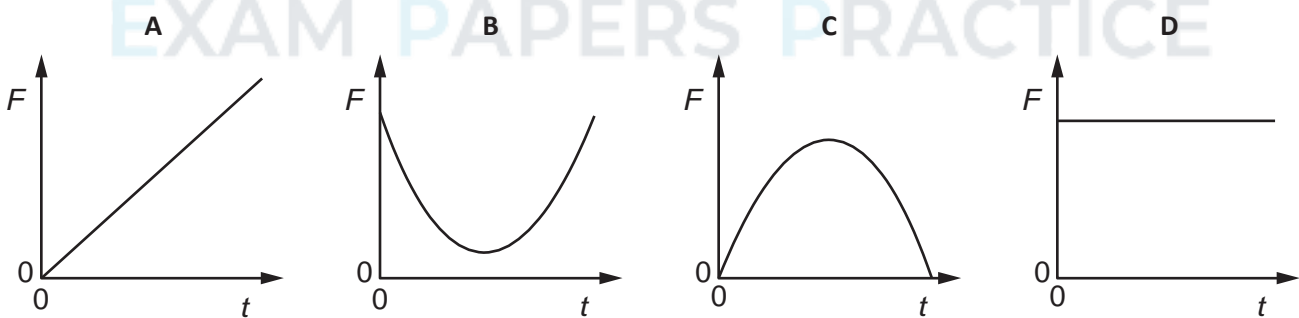

32. The graph shows how velocity  $v$  varies with time  $t$  for a bungee jumper.

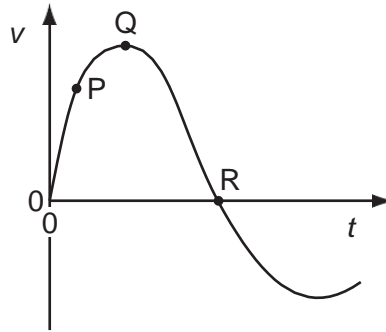

At which point is the bungee jumper momentarily at rest and at which point does she have zero acceleration?

	jumper at rest	jumper with zero acceleration
A	Q	P
B	Q	R
C	R	Q
D	R	R

33. The graph shows how the velocity  $v$  of a firework rocket changes with time  $t$ .  
 At which point on the graph does the rocket have the greatest acceleration?

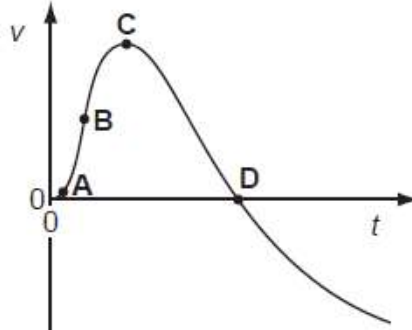

34. A car is stationary at traffic lights. When the traffic lights go green, the driver presses down sharply on the accelerator. The resultant horizontal force acting on the car varies with time as shown.

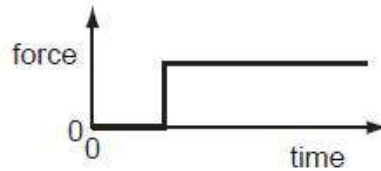

Which graph shows the variation with time of the speed of the car?

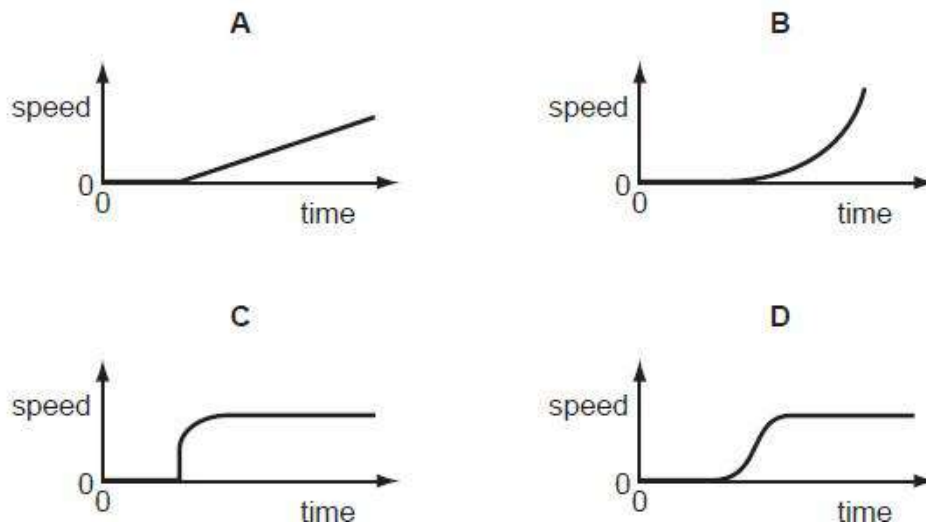

35. A sky diver falls vertically from a stationary balloon. She leaves the balloon at time  $t = 0$ . At time  $t = T$ , she reaches terminal velocity. Beyond the time shown in the graphs, she opens her parachute.

Which graph shows the variation with time  $t$  of the force  $F$  due to air resistance?

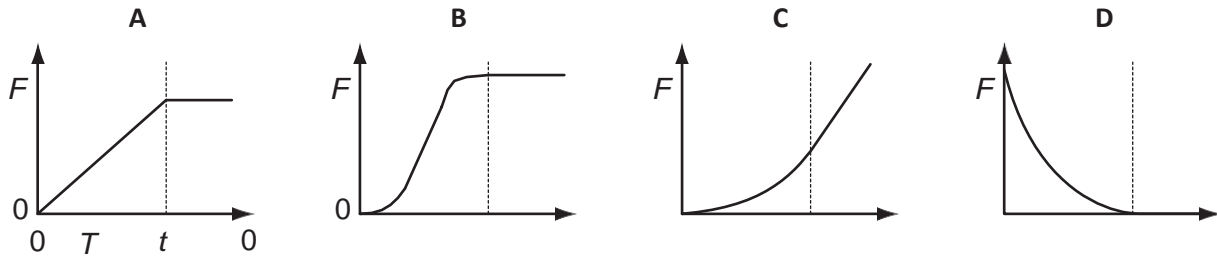

36. The graph shows how the acceleration of an object moving in a straight line varies with time.

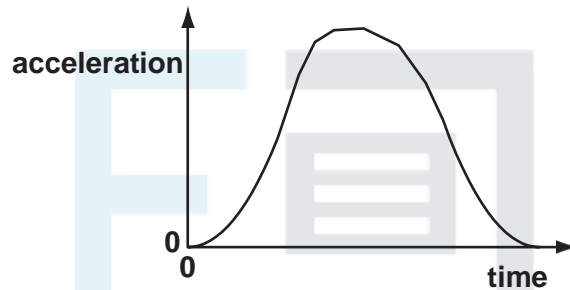

Which graph shows the variation with time of the velocity of the object?

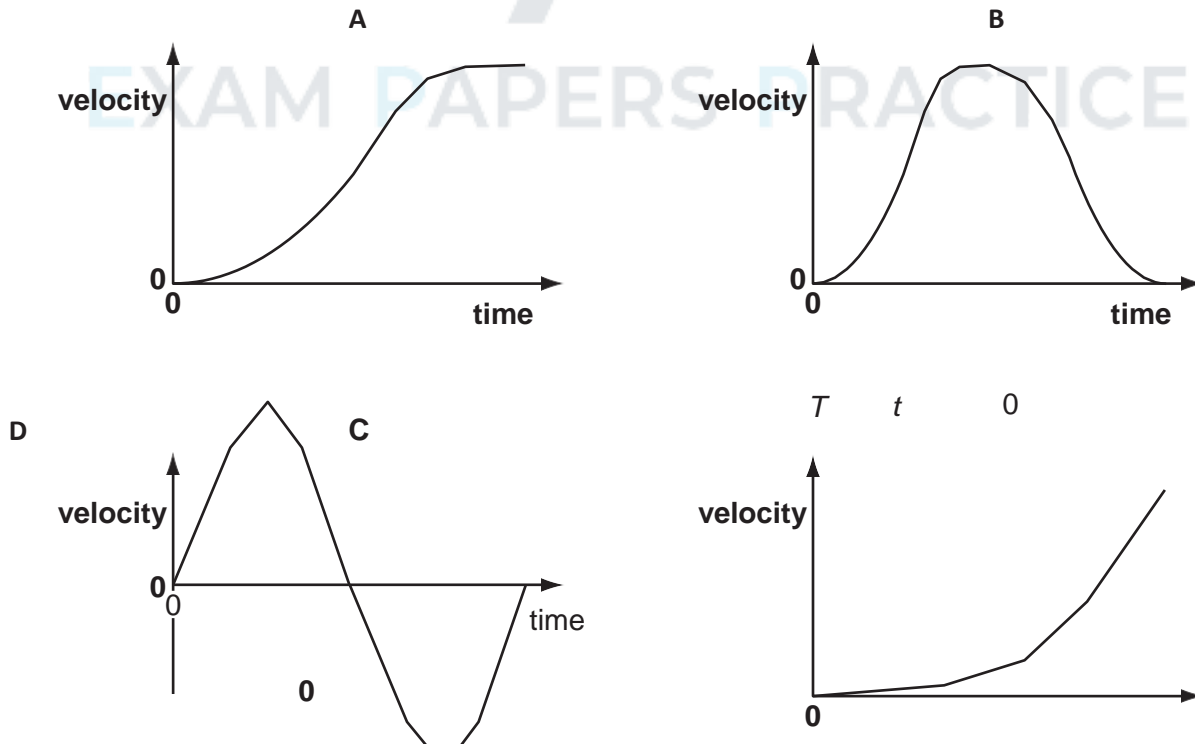

e  
0

t  
i  
m

37. A ball is released from rest at time zero. After 1.0 s it bounces inelastically from a horizontal surface and rebounds, reaching the top of its first bounce after 1.5 s.

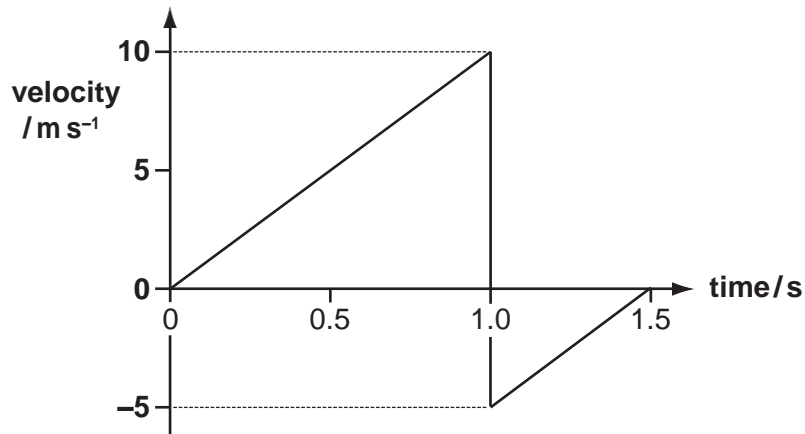

What is the total displacement of the ball from its original position after 1.5 s?

- A 1.25 m      B 3.75 m      C 5.00 m      D 6.25 m

38. A particle moves in the manner shown by the velocity-time graph.

The displacement of the particle has been measured so that it is zero at  $t = 0$ . Point Q refers to a point in its motion.

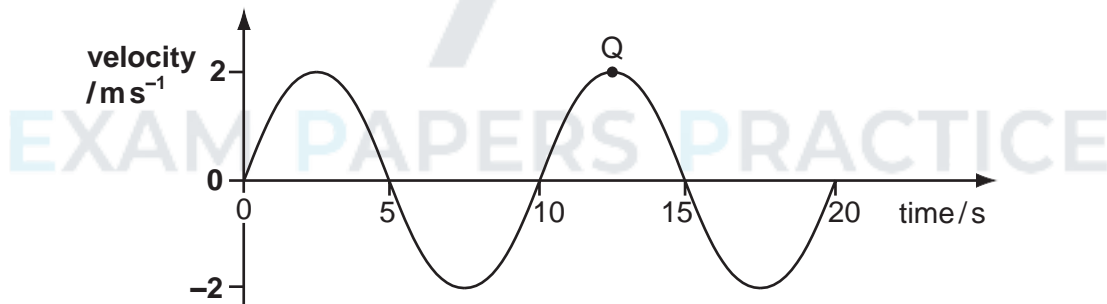

Which row of the table is correct?

	times for maximum displacement / s		acceleration at point Q / $\text{m s}^{-2}$
A	2.5	12.5	2
B	5	15	2
C	2.5	12.5	0
D	5	15	0

39. A tennis ball falls freely, in air, from the top of a tall building.

Which graph best represents the variation of distance  $s$  fallen with time  $t$ ?

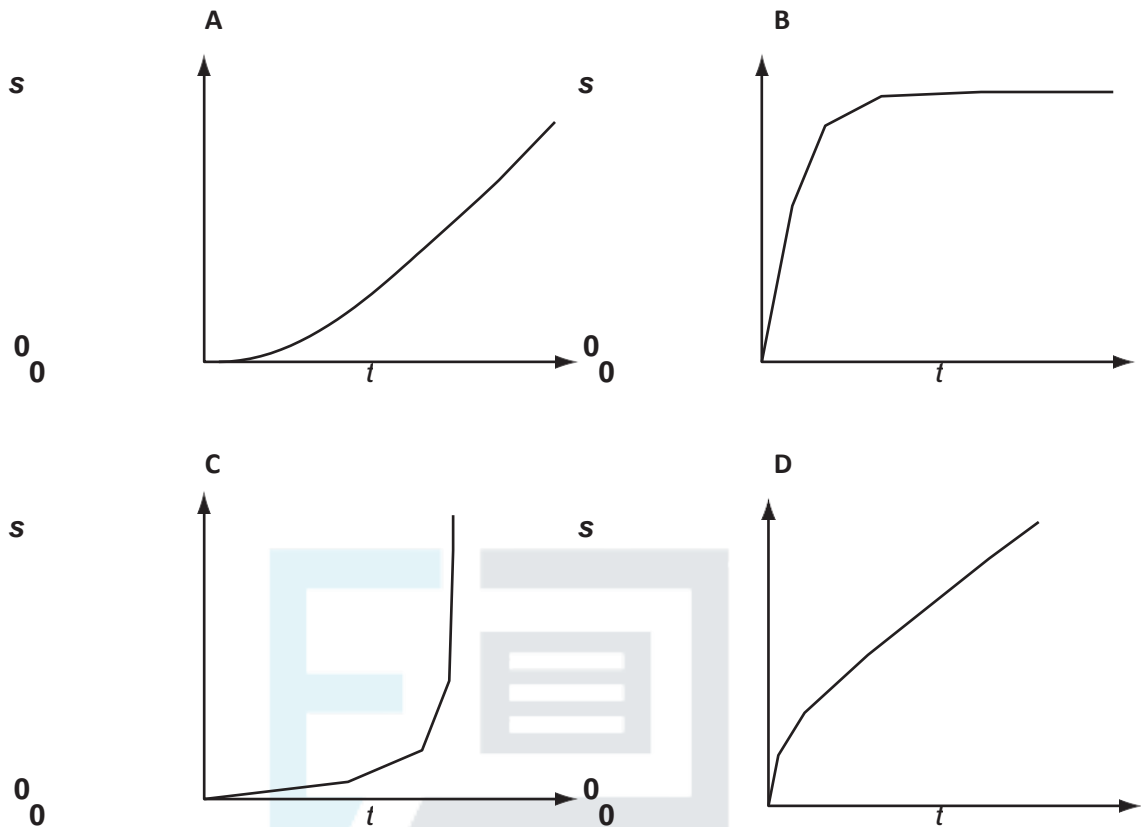

40. A small glider moves along a friction-free horizontal air track as shown below.

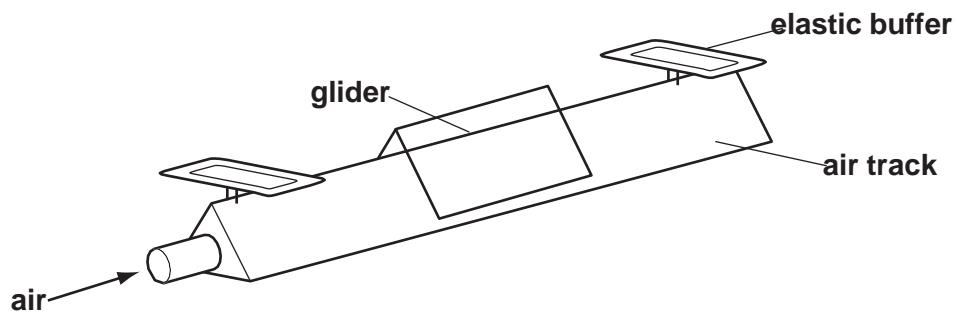

At each end of the air track there is a perfectly elastic buffer.

Which graph represents the variation with time  $t$  of the velocity  $v$  of the glider as it moves between the two buffers?

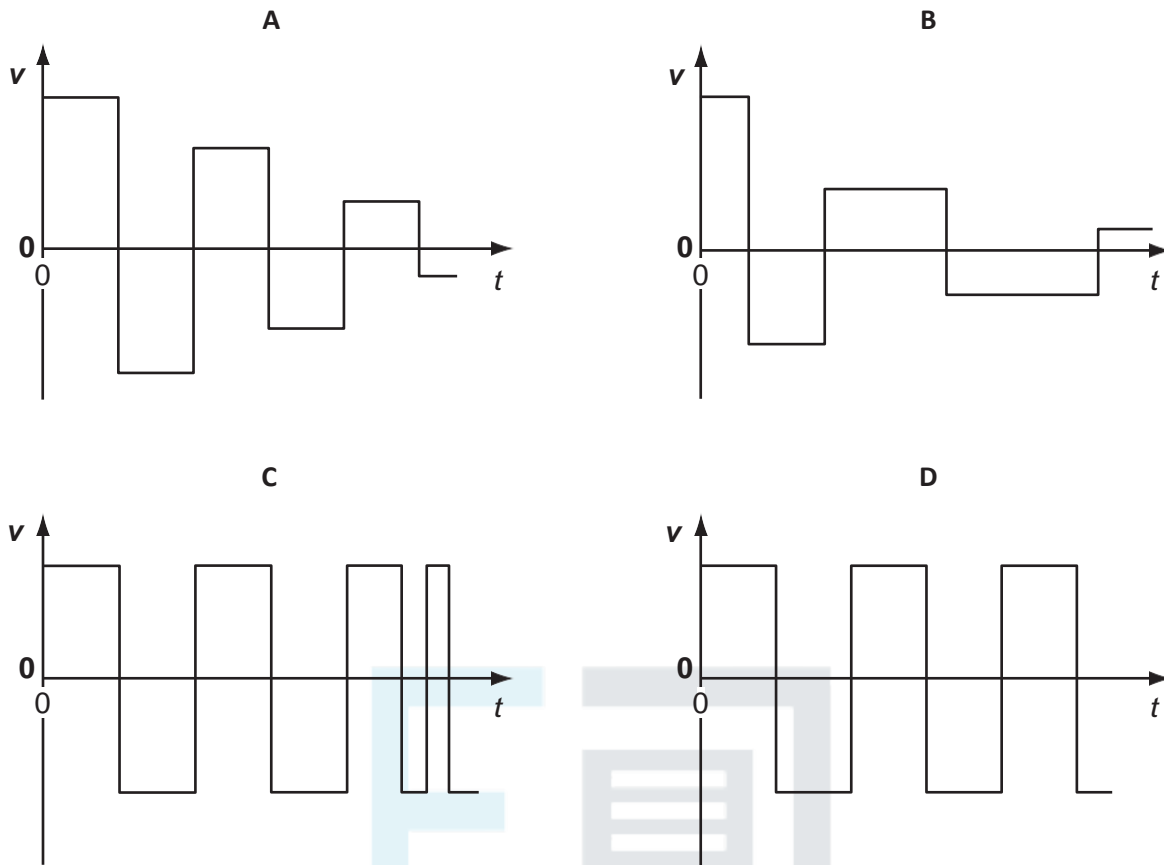

41. The diagram shows a velocity-time graph for a mass moving up and down on the end of a spring. Which point represents the velocity of the mass when at the lowest point of its motion?

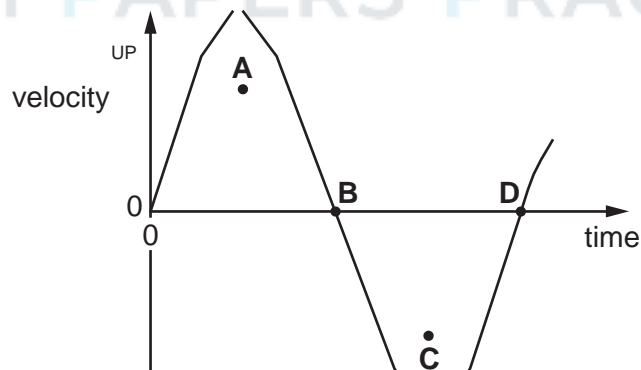

42. A ball is released from rest on a smooth slope XY.

It moves down the slope, along a smooth horizontal surface YZ and rebounds inelastically at Z. Then it moves back to Y and comes to rest momentarily somewhere on XY.

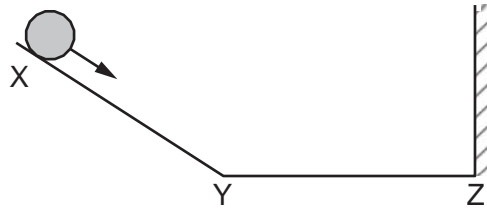

Which velocity-time graph represents the motion of the ball?

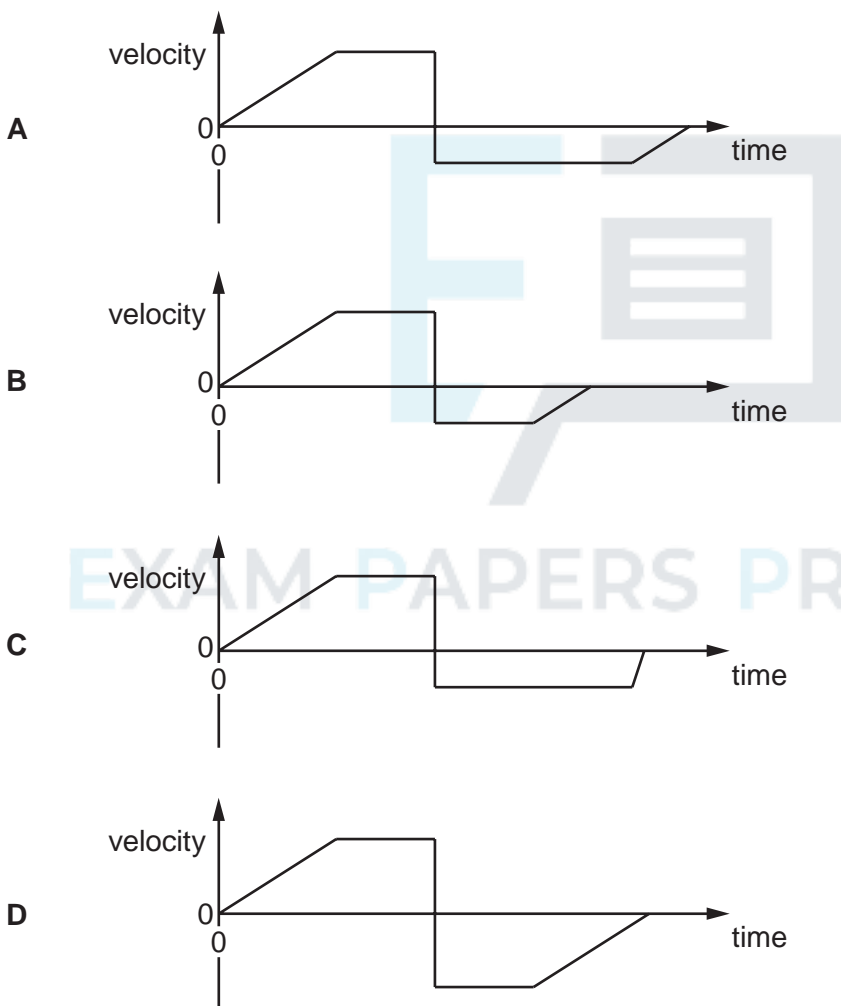



43. The graph shows how the acceleration of an object moving in a straight line varies with time.

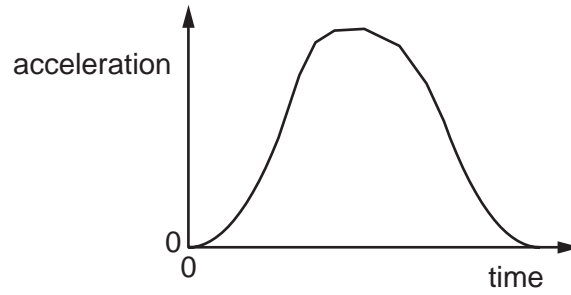

The object starts from rest.

Which graph shows the variation with time of the velocity of the object over the same time interval?

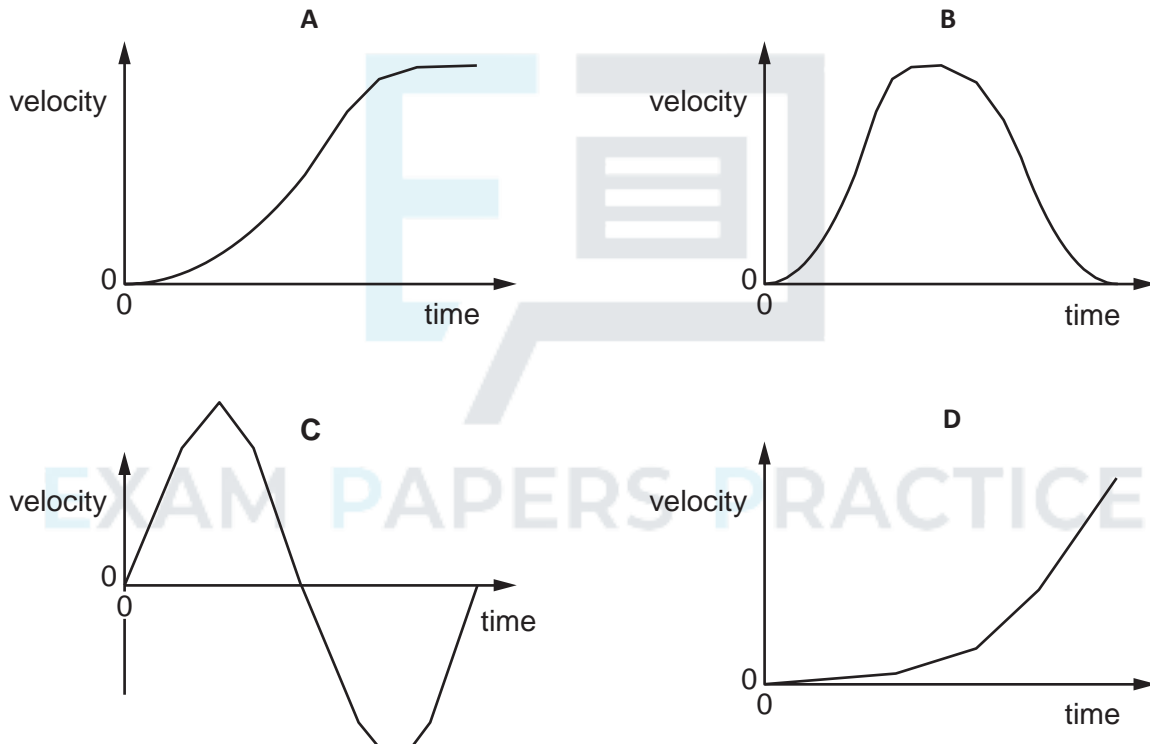

44. A radio-controlled toy car travels along a straight line for a time of 15 s.  
 The variation with time  $t$  of the velocity  $v$  of the car is shown below.

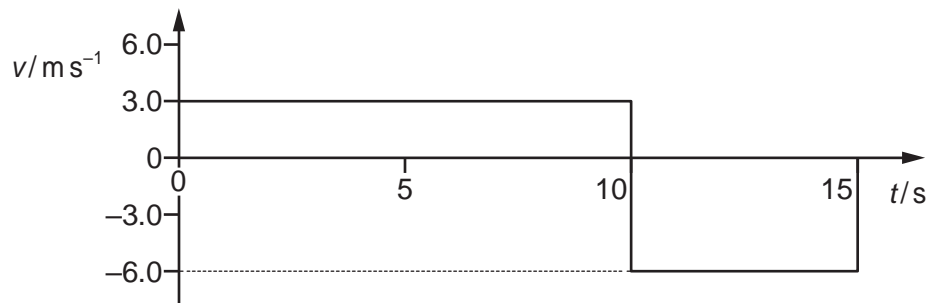

What is the average velocity of the toy car for the journey shown by the graph?

- A  $-1.5 \text{ms}^{-1}$     B  $0.0 \text{ms}^{-1}$     C  $4.0 \text{ms}^{-1}$     D  $4.5 \text{ms}^{-1}$

45. The graph shows how the speed  $v$  of a sprinter changes with time  $t$  during a 100 m race.

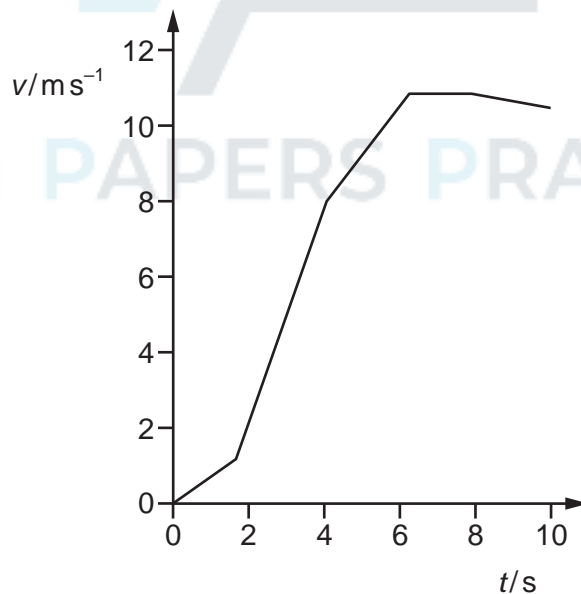

What is the best estimate of the maximum acceleration of the sprinter?

- A  $0.5\text{ms}^{-2}$       B  $1\text{ms}^{-2}$       C  $3\text{ms}^{-2}$       D  $10\text{ms}^{-2}$

46. A ball is released from rest above a horizontal surface. It bounces once and is caught.

Which graph represents the variation with time  $t$  of the velocity  $v$  of the ball?

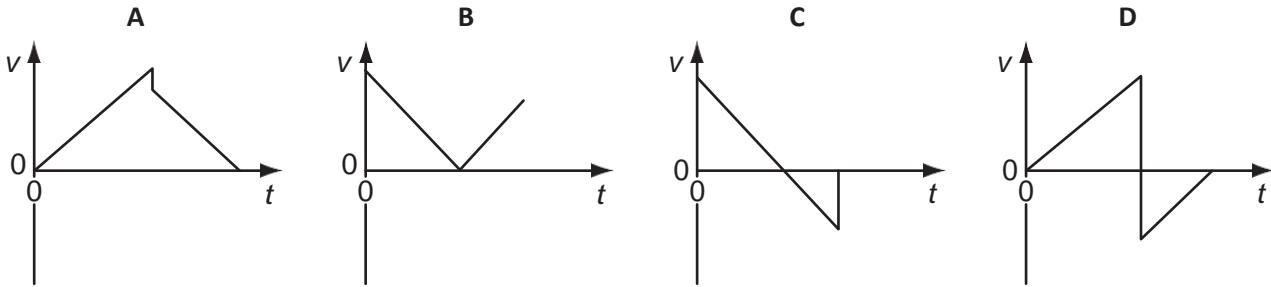

47. A mass on the end of a spring bounces up and down as shown, after being released at time  $t = 0$ .

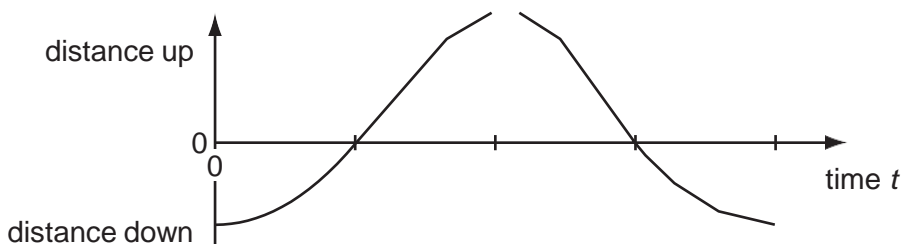

Which graph shows how the velocity varies with time?

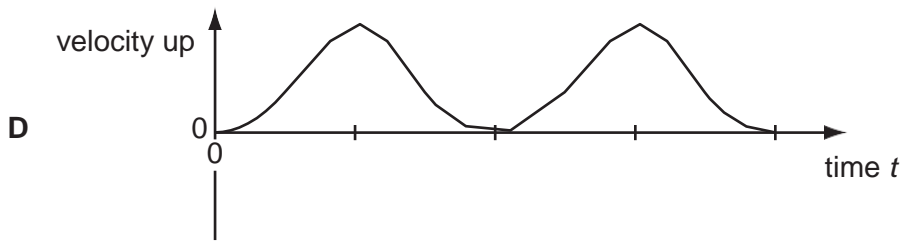
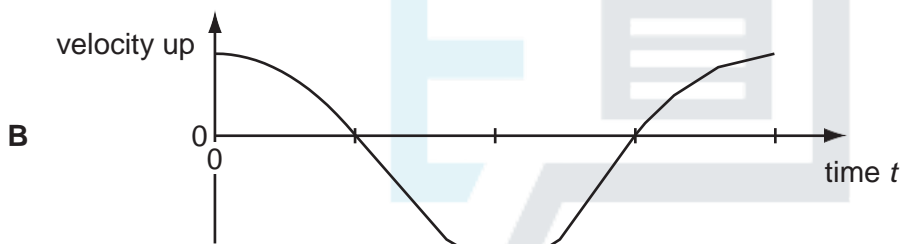
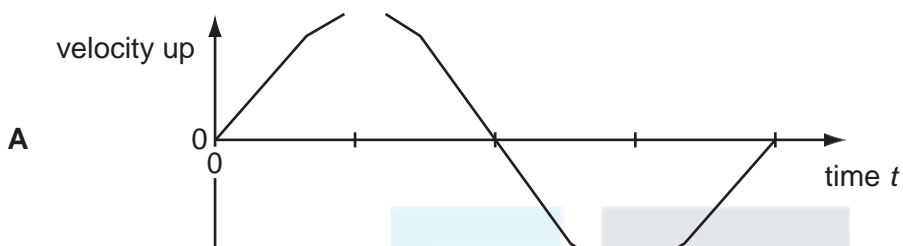

48. Which feature of a graph allows acceleration to be determined?
- the area under a displacement-time graph
  - the area under a velocity-time graph
  - the slope of a displacement-time graph
  - the slope of a velocity-time graph
49. The diagram shows a barrel suspended from a frictionless pulley on a building. The rope supporting the barrel goes over the pulley and is secured to a stake at the bottom of the building.

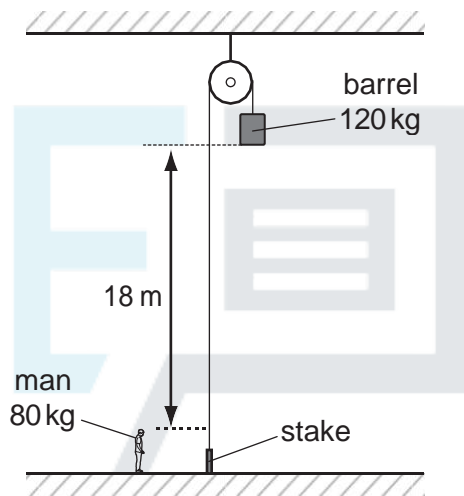

A man stands close to the stake. The bottom of the barrel is 18 m above the man's head. The mass of the barrel is 120 kg and the mass of the man is 80 kg.

The man keeps hold of the rope after untying it from the stake and is lifted upwards as the barrel falls.

What is the man's upward speed when his head is level with the bottom of the barrel? (Use  $g = 10 \text{ ms}^{-2}$ .)

- A  $6 \text{ ms}^{-1}$       B  $8 \text{ ms}^{-1}$       C  $13 \text{ ms}^{-1}$       D  $19 \text{ ms}^{-1}$

50. The graph shows how the velocity  $v$  of an object moving in a straight line varies over time  $t = 0$  to  $t = T$ .

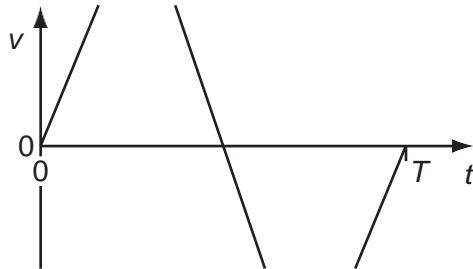

Which graph represents the displacement  $s$  of the object in the time  $t = 0$  to  $t = T$ ?

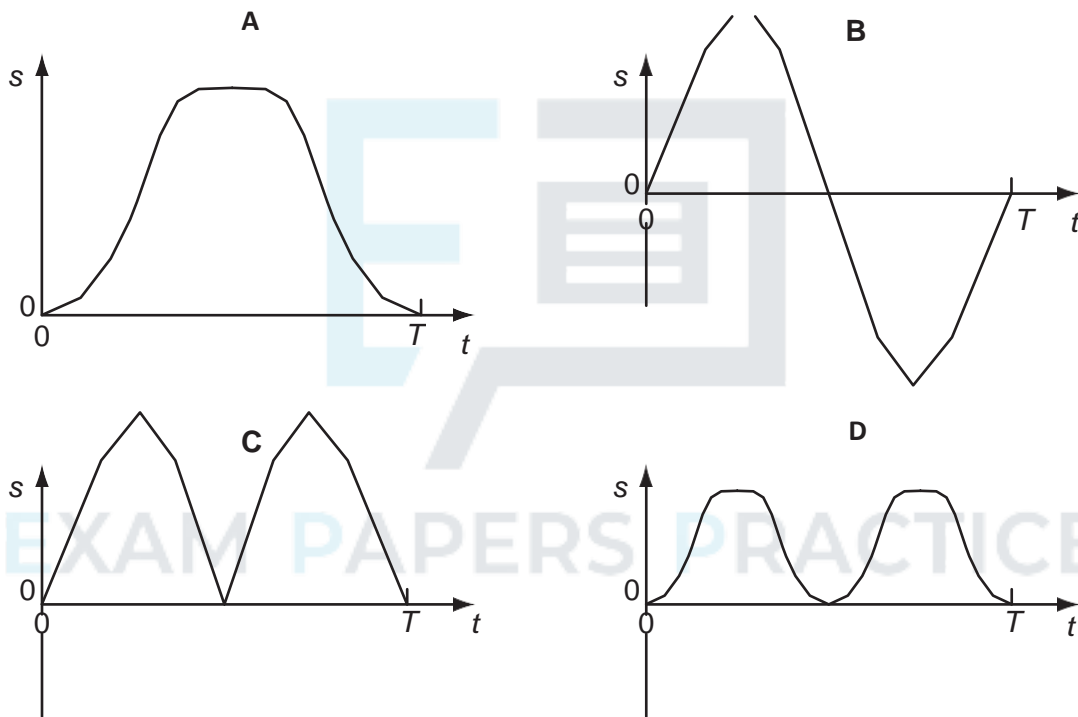

51. When a car driver sees a hazard ahead, she applies the brakes as soon as she can and brings the car to rest. The graph shows how the speed  $v$  of the car varies with time  $t$  after the hazard is seen.

For more help, please visit [www.exampaperspractice.co.uk](http://www.exampaperspractice.co.uk)

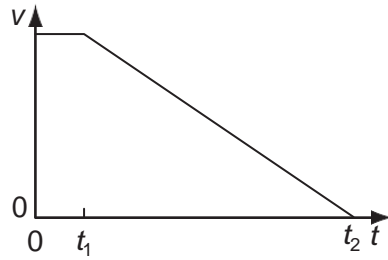

Which graph represents the variation with time  $t$  of the distance  $s$  travelled by the car after the hazard has been seen?

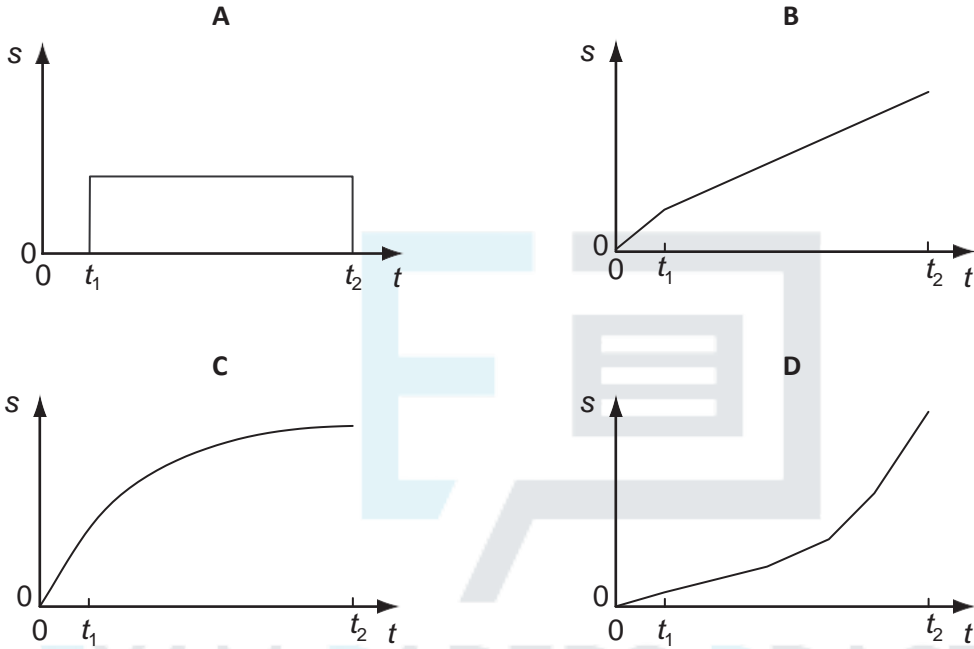

52. A tennis ball is released from rest at the top of a tall building.

Which graph best represents the variation with time  $t$  of the acceleration  $a$  of the ball as it falls, assuming that the effects of air resistance are appreciable?

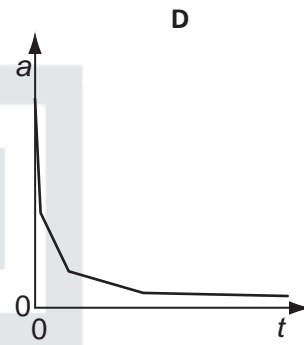
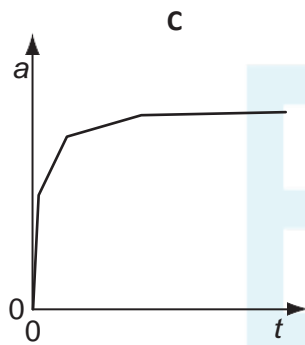
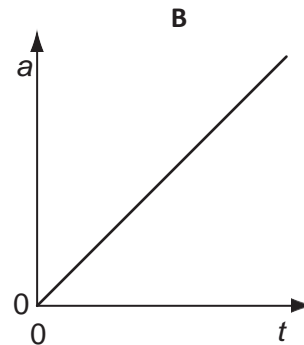
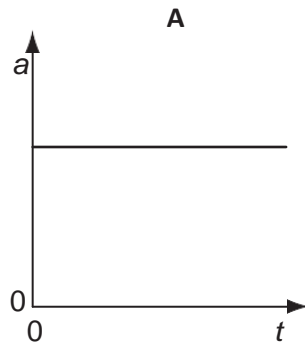



53. A car at rest in a traffic queue moves forward in a straight line and then comes to rest again. The graph shows the variation with time of its displacement.

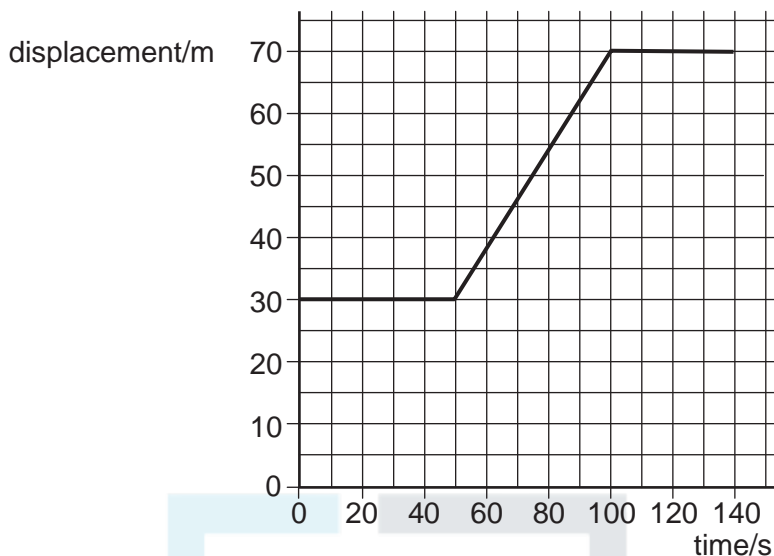

What is its speed while it is moving?

- A**  $0.70 \text{ m s}^{-1}$     
 **B**  $0.80 \text{ m s}^{-1}$     
 **C**  $1.25 \text{ m s}^{-1}$     
 **D**  $1.40 \text{ m s}^{-1}$
54. An object is dropped from a great height and falls through air of uniform density.

The acceleration of free fall is  $g$ .

Which graph could show the variation with time  $t$  of the acceleration  $a$  of the object?

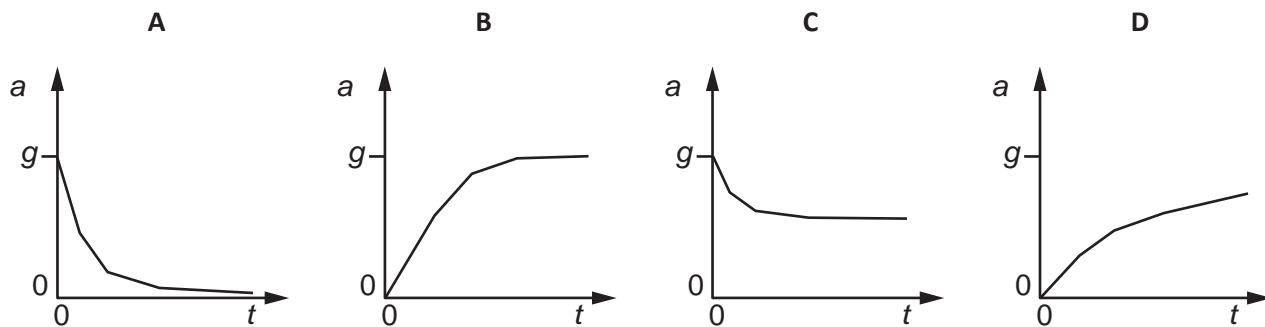

55. A car accelerates in a straight line.

A graph of the momentum of the car is plotted against time.

What is evaluated by finding the gradient of the graph at a particular time?

- A the acceleration of the car
- B the resultant force on the car
- C the kinetic energy of the car
- D the power supplied to the car

56. The dotted line shows the path of a competitor in a ski-jumping competition.

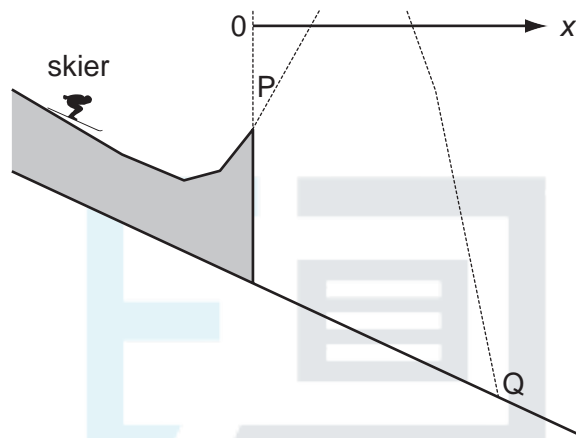

Ignoring air resistance, which graph best represents the variation of his speed  $v$  with the horizontal distance  $x$  covered from the start of his jump at P before landing at Q?

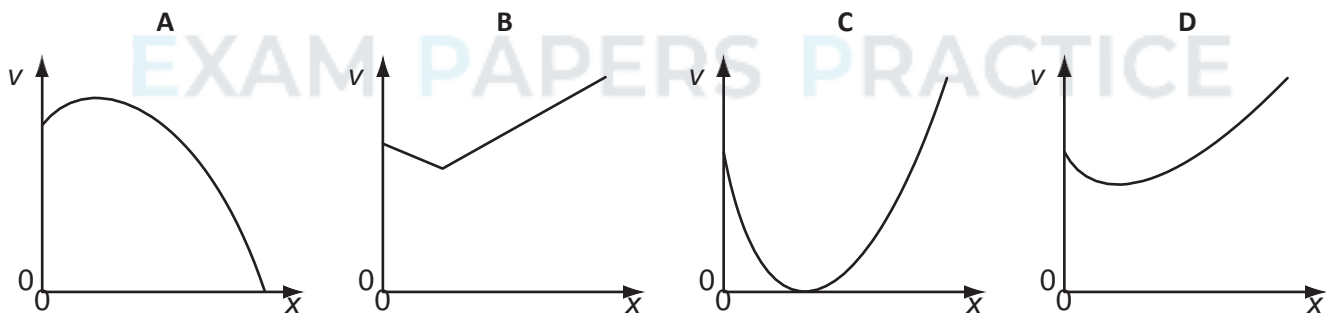

57. The velocity of a car changes as shown. At time  $t = 0$ , a body moves from rest with constant acceleration in a straight line. At time  $t$ , the body is distance  $s$  from its rest position.

A graph is drawn of  $s$  against  $t^2$ , as shown.

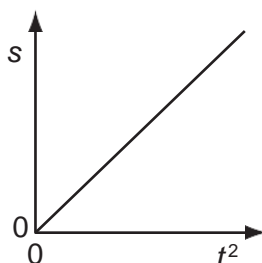

Which statement describes the acceleration of the body?

- A It is equal to half the value of the gradient of the graph.
- B It is equal to the value of the gradient of the graph.
- C It is equal to twice the value of the gradient of the graph.
- D It is equal to the reciprocal of the gradient of the graph.



EXAM PAPERS PRACTICE

58. The velocity of an electric car changes as shown.

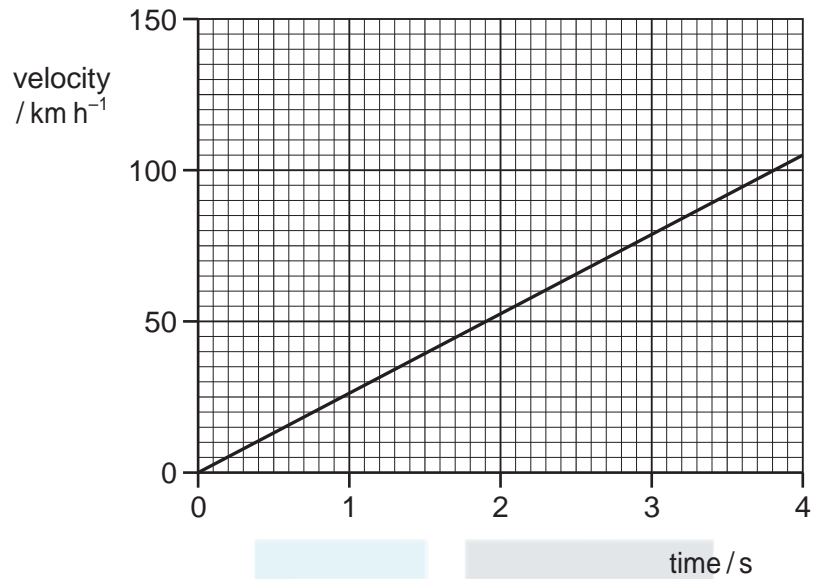

What is the acceleration of the car?

- A  $190 \text{ ms}^{-2}$       B  $53 \text{ ms}^{-2}$       C  $26 \text{ ms}^{-2}$       D  $7.3 \text{ ms}^{-2}$

59. A brick is dislodged from a building and falls vertically under gravity.

Which graph best represents the variation of its height  $h$  above the ground with time  $t$  if air resistance is negligible?

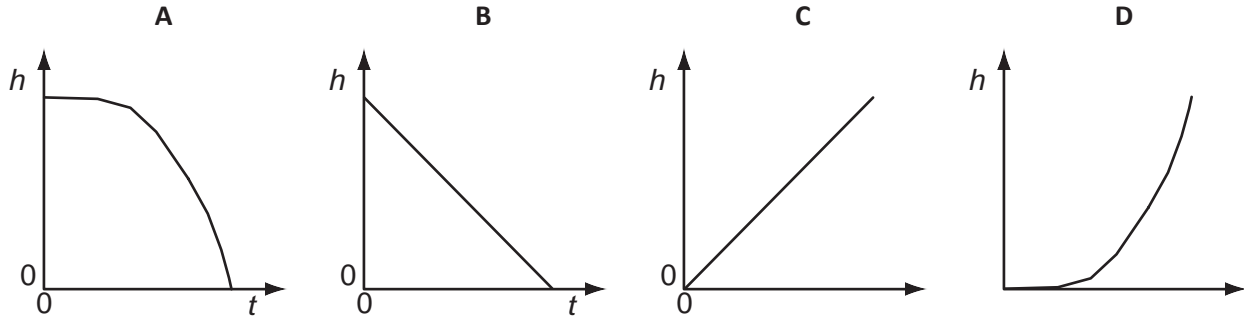

60. A ball is released from rest on a smooth slope XY.

It moves down the slope, along a smooth horizontal surface YZ and rebounds inelastically at Z. Then it moves back to Y and comes to rest momentarily somewhere on XY.

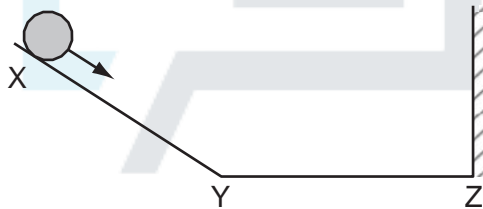

Which velocity-time graph represents the motion of the ball?

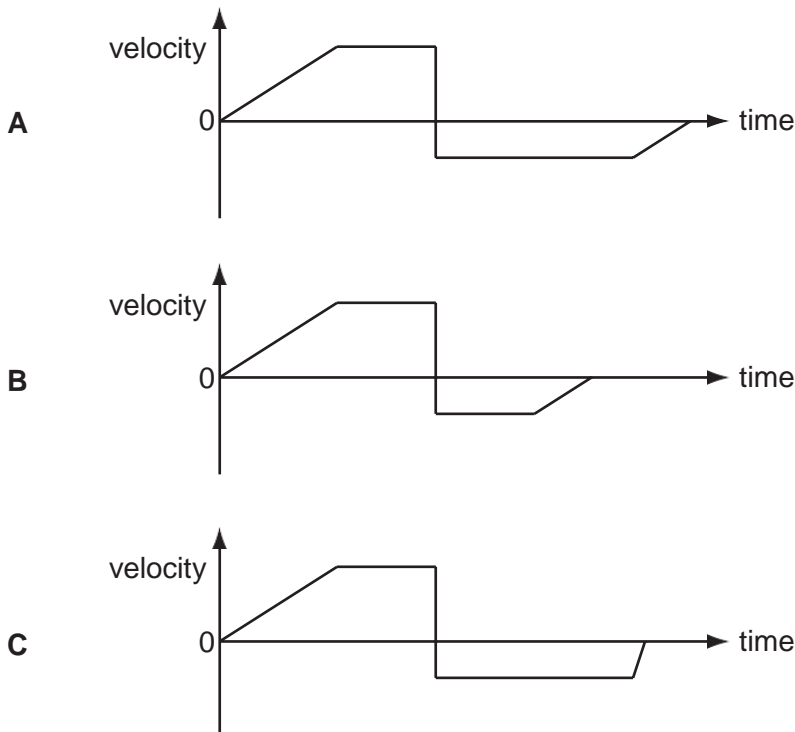

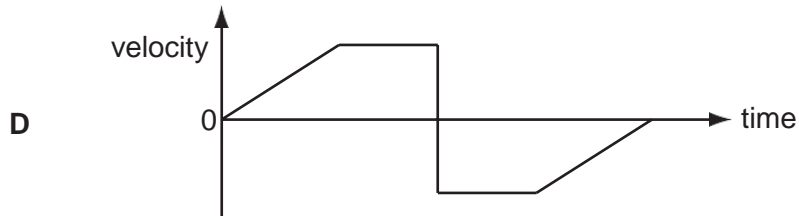

61. A tennis ball is released from rest at the top of a tall building.

Which graph best represents the variation with time  $t$  of the acceleration  $a$  of the ball as it falls, assuming that the effect of air resistance is not negligible?

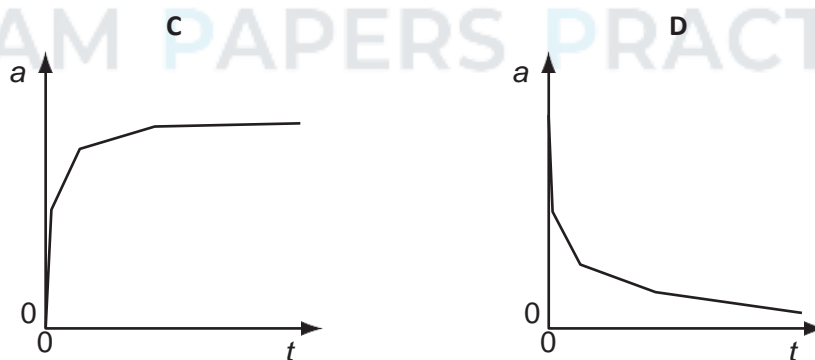
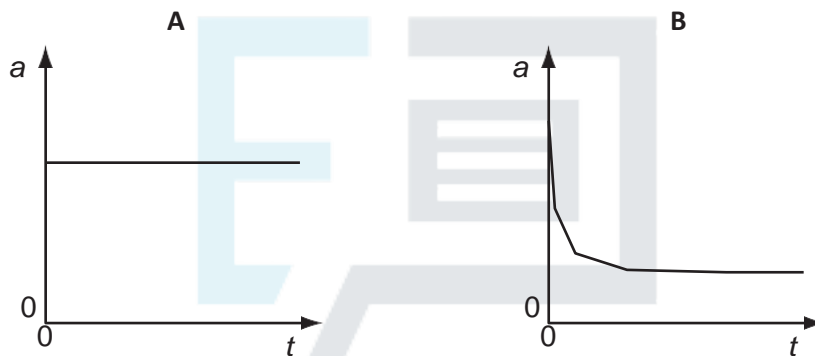

62. The velocity of an object during the first five seconds of its motion is shown on the graph.

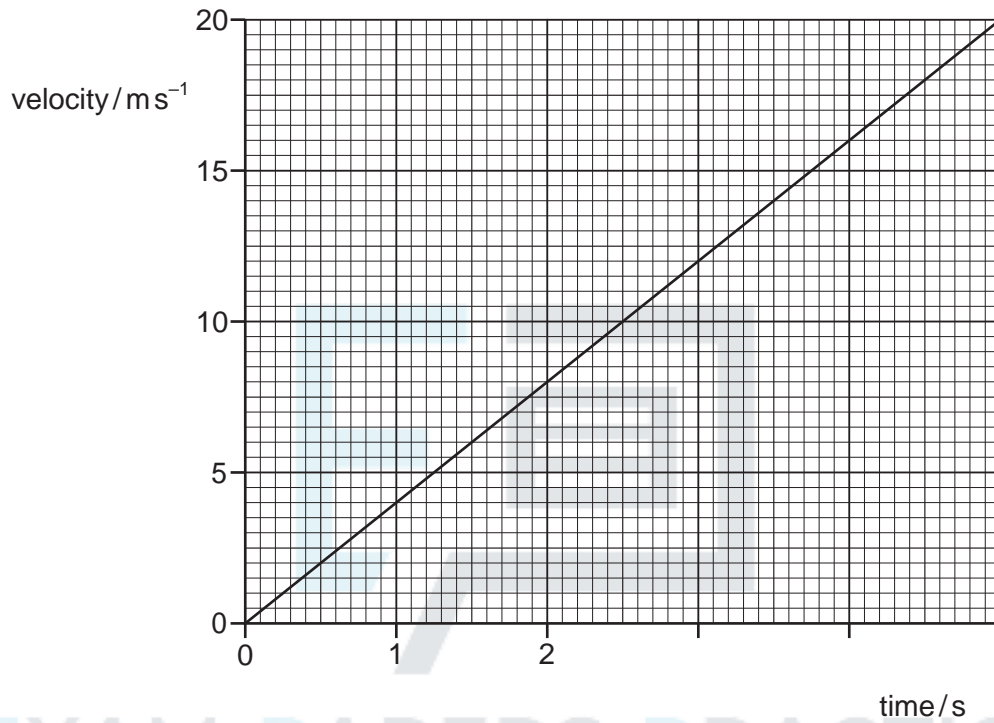

What is the distance travelled by the object in this time?

- A 4 m                      B 20 m                      C 50 m                      D 100 m

63. The variation with time  $t$  of the distance  $s$  moved by a body is shown below.

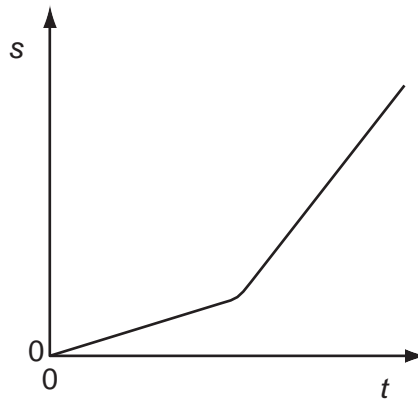

What can be deduced from the graph about the motion of the body?

For more help, please visit [www.exampaperspractice.co.uk](http://www.exampaperspractice.co.uk)

- A It accelerates continuously.
- B It starts from rest.
- C The distance is proportional to time.
- D The speed changes.



EXAM PAPERS PRACTICE





64. The velocity-time graph below is for a stone thrown vertically up into the air. Air resistance is negligible.

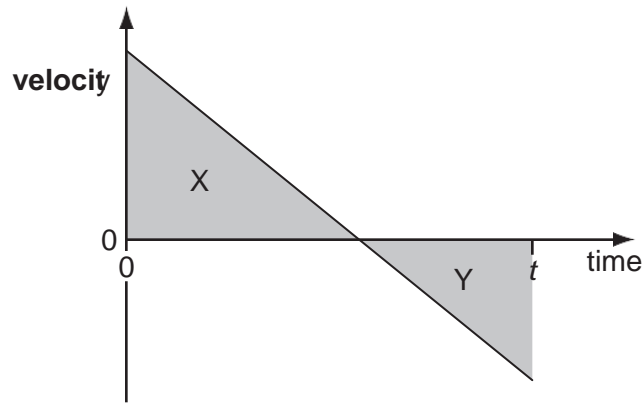

The stone is thrown up at time zero.

Area X represents a distance of 5 m. Area Y represents a distance of 3 m.

What is the displacement of the stone from its initial position at time  $t$ ?

- A 2 m                      B 3 m                      C 5 m                      D 8 m

65. A student throws a ball in the positive direction vertically upwards.

The ball makes an elastic collision with the ceiling, rebounds and accelerates back to the student's hand in a time of 1.2s.

Which graph best represents the acceleration of the ball from the moment it leaves the hand to the instant just before it returns to the hand?

