

1 Unstable nuclei can emit particles.

(a) Which of these particles has the largest charge? (1)

- A alpha particle
- B beta particle
- C neutron
- D proton

(b) Which of these particles has the largest mass? (1)

- A alpha particle
- B beta particle
- C neutron
- D proton

(c) The maximum range of a beta particle in air is about (1)

- A 50 mm
- B 50 cm
- C 50 m
- D 50 km

(d) When a nucleus emits a beta particle (1)

- A the nucleon number decreases by 1
- B the nucleon number increases by 1
- C the proton number decreases by 1
- D the proton number increases by 1

---

**(Total for Question 1 = 4 marks)**



2 The photograph shows an old camera lens that contains several pieces of glass.



One of the pieces of glass includes a radioactive isotope, thorium-232.

(a) Thorium-232 undergoes alpha decay and produces an isotope of radium, Ra.

Complete the equation for this decay.

(2)

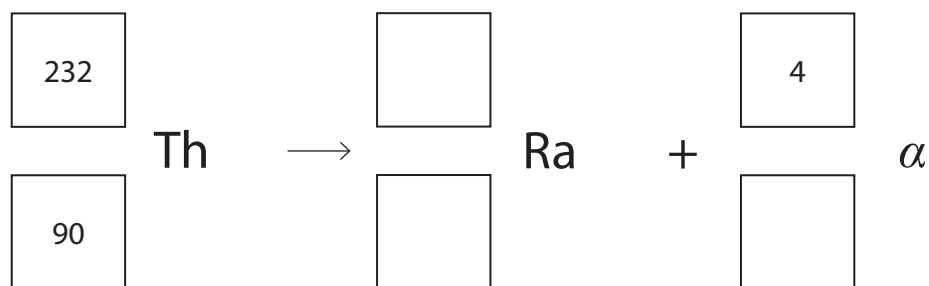



(b) The radioactive glass also emits beta particles from a different isotope.

The diagram shows the position of the radioactive glass in the camera.

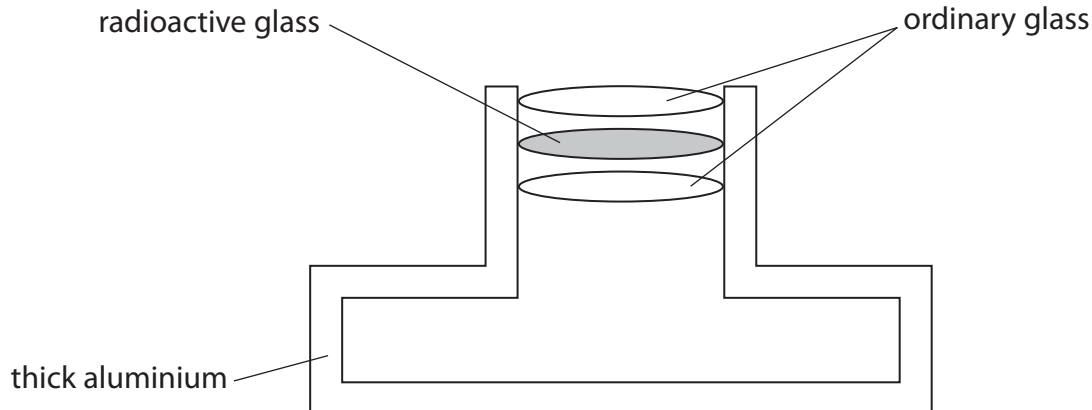

(i) Suggest why it is safe to use radioactive glass in the camera as shown.

(1)

.....

.....

.....

.....

(ii) Amateur astronomers sometimes remove an old camera lens to use as a lens in a homemade telescope.

Suggest why an astronomer should not use a lens with radioactive glass close to their eye.

(2)

.....

.....

.....

.....

.....

.....

**(Total for Question 2 = 5 marks)**

- 3 (a) Scientists use deflection in an electric field to help distinguish between different radiations.

The diagram shows a beam containing several types of radiation. This beam travels in a vacuum between two charged plates.

Some of the radiations are deflected upwards, some are deflected downwards and some are not deflected at all.

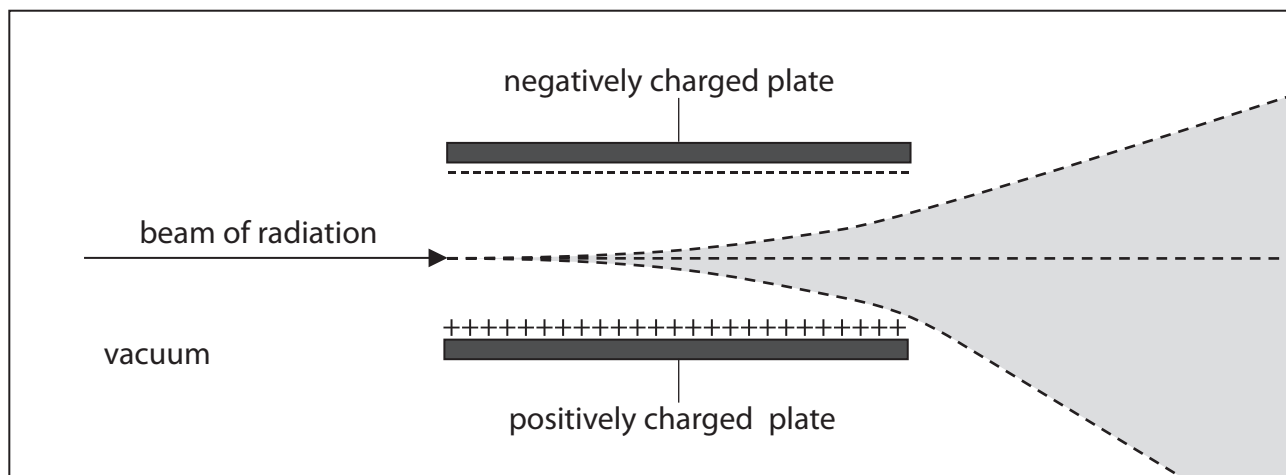

Put one tick in each row to show the correct deflection for each type of radiation.

One has been done for you.

(4)

Type of radiation	Deflected upwards	Deflected downwards	Not deflected
alpha	✓		
beta			
gamma			
neutrons			
protons			

(b) The diagram shows the apparatus Geiger and Marsden used to investigate the structure of an atom.

They aimed a beam of alpha particles at a very thin sheet of gold foil.

They used a zinc sulfide screen to detect the alpha particles.

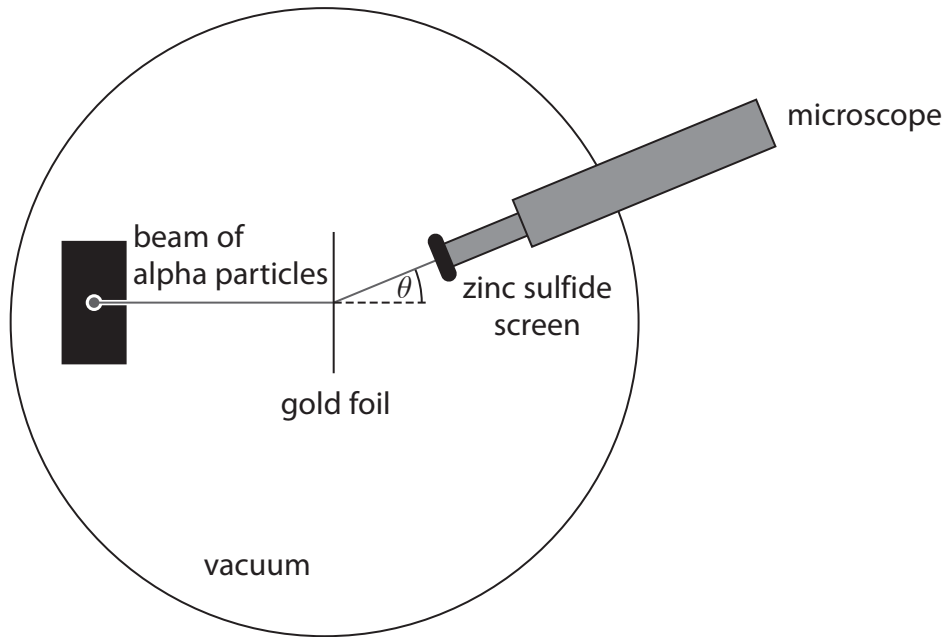

(i) Suggest why Geiger and Marsden removed the air from the apparatus.

(1)

.....

.....

.....

(ii) Describe Geiger and Marsden's results.

(2)

.....

.....

.....

.....

.....

.....



(c) Rutherford produced a model of the atom.

Describe how Rutherford’s model explains Geiger and Marsden’s results.

You may draw a diagram to help your answer.

(4)

.....

.....

.....

.....

.....

.....

.....

.....

.....

.....

.....

.....

.....

.....

.....

.....

.....

.....

.....

.....

.....

.....

**(Total for Question 3 = 11 marks)**

- 4 In 2013, the UK Government decided to build another nuclear power station at Hinckley Point. Hinckley Point is in Somerset, a major agricultural area of the UK. This will be the third nuclear power station at the site.



©guardian

Discuss the advantages and disadvantages of nuclear power stations and biomass power stations.

(6)

.....

.....

.....

.....

.....

.....

.....

.....

.....

.....

.....

.....

.....

.....

.....

.....

.....

.....

.....

.....

.....

.....

.....

.....

---

**(Total for Question 4 = 6 marks)**

5 Use the following information to help you answer the questions.

### The gold foil experiment

Scientists used to think that electrons were spread out through a positively charged atom.

They called this the 'plum pudding' model.

To test this idea, scientists aimed alpha particles at thin gold foil. They expected the alpha particles to pass straight through.

The results showed that **almost** all the alpha particles did pass straight through, but a few did not. About 1 in every 8000 was deflected away at a very large angle.

It was these 'anomalous' results that led to a new understanding of the atom.



(a) What was the prediction in this experiment?

EXAM PAPERS PRACTICE <sup>(1)</sup>

.....

.....

.....

(b) (i) What do scientists mean by **anomalous results**?

(1)

.....

.....

.....

(ii) How should scientists deal with anomalous results?

(1)

.....

.....

.....





(c) Describe how a teacher should measure the activity of a radioactive source using a Geiger-Muller detector.

(4)

.....

.....

.....

.....

.....

.....

.....

.....

.....

.....

.....

.....

.....

.....

.....

.....

.....

.....

.....

.....

.....

.....

**(Total for Question 6 = 7 marks)**