



1 (a) State the factors which completely describe a vector quantity.

.....  
..... [1]

(b) An aeroplane is flying towards the east in still air at 92m/s. A wind starts to blow at 24 m/s towards the north.

Draw a vector diagram to find the resultant velocity of the aeroplane. Use a scale of 1.0cm = 10m/s.

resultant speed = .....

angle between resultant and easterly direction = ..... [5]

[Total: 6]

2 (a) A stationary body is acted upon by a number of forces. State the two conditions which must apply for the body to remain at rest.

1. ....

2. ....

[2]

(b) Fig. 3.1 shows a device used for compressing crushed material.

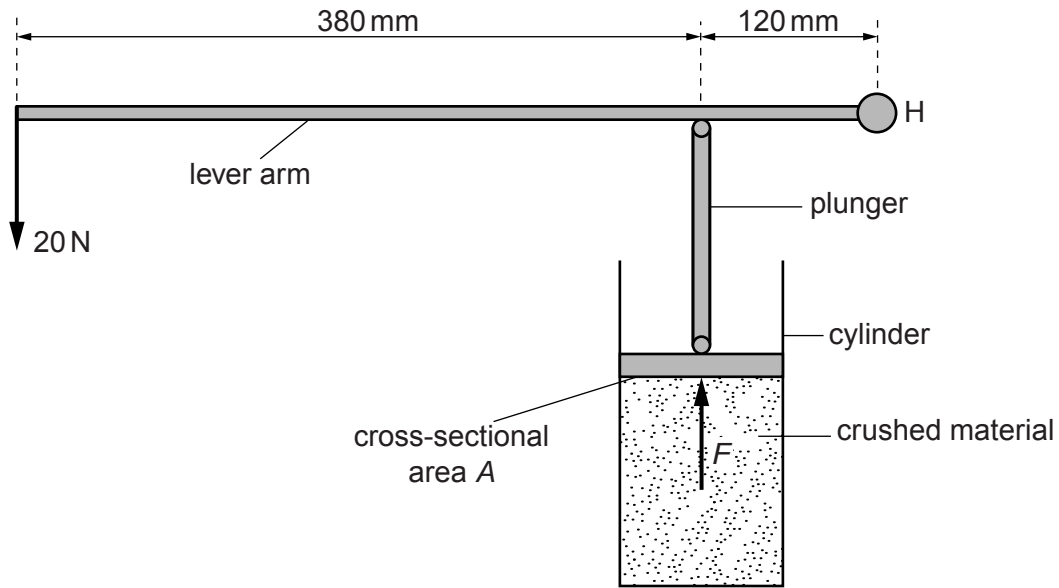

**Fig. 3.1**

The lever arm rotates about the hinge H at its right-hand end. A force of 20 N acts downwards on the left-hand end of the lever arm. The force  $F$  of the crushed material on the plunger acts upwards. Ignore the weight of the lever arm.

(i) Use the clockwise and anticlockwise moments about H to calculate the upward force  $F$  which the crushed material exerts on the plunger. The distances are shown on Fig. 3.1.

force  $F =$  ..... [3]



- (ii) The cross-sectional area  $A$  of the plunger in contact with the crushed material is  $0.0036 \text{ m}^2$ . Calculate the pressure exerted on the crushed material by the plunger.

pressure = ..... [2]

[Total: 7]

- 3 Fig. 2.1 is a head-on view of an airliner flying at constant speed in a circular horizontal path. The centre of the circle is to the left of the diagram.

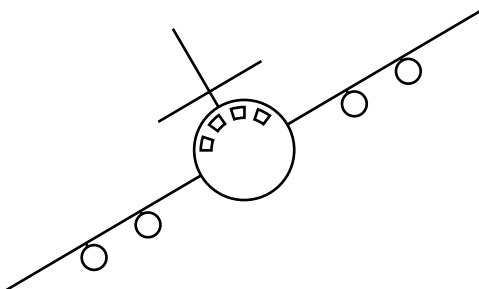

**Fig. 2.1**

- (a) On Fig. 2.1, draw the resultant force acting on the airliner. Explain your answer.

.....  
.....  
..... [3]

- (b) The weight of the airliner is  $1.20 \times 10^6$  N and there is an aerodynamic lift force of  $1.39 \times 10^6$  N acting at  $30^\circ$  to the left of the vertical.

By drawing a scale vector diagram, or otherwise, show that the resultant of these two forces is in the same direction as the resultant force you drew in (a).

(c) The speed is constant as the airliner flies in this circular path.

State and explain what is happening to the velocity.

.....

.....

.....

..... [2]

[Total: 8]

- 4 Fig. 3.1 shows an aeroplane of mass  $3.4 \times 10^5 \text{ kg}$  accelerating uniformly from rest along a runway.

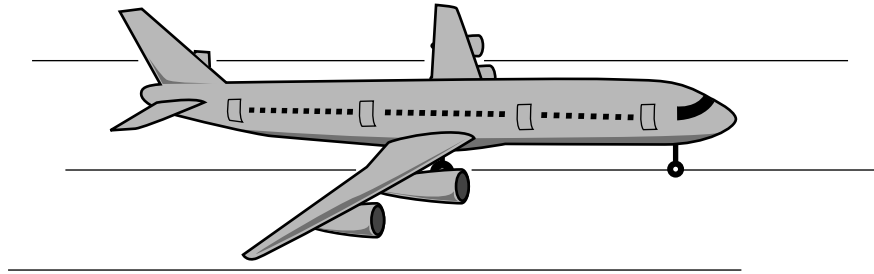

**Fig. 3.1**

After 26 s it reaches a speed of 65 m/s.

**(a)** Calculate

- (i)** the acceleration of the aeroplane,

acceleration = ..... [2]

- (ii)** the resultant force on the aeroplane.

force = ..... [2]

**(b)** Just after taking off, the aeroplane continues to accelerate as it gains height.

- (i)** State **two** forms of energy that increase during this time.

1. ....

2. .... [2]

- (ii)** State **one** form of energy that decreases during this time.

..... [1]

(iii) State why the total energy of the aeroplane decreases during this time.

.....  
..... [1]

(c) When the aeroplane reaches its maximum height, it starts to follow a curved path at a constant speed.

State the direction of the resultant force on the aeroplane.

..... [1]

[Total: 9]

5 (a) Complete the following statement:

The moment of a force about a point is .....

multiplied by .....[1]

(b) Fig. 3.1 shows a uniform iron bar B of weight 30 N and length 1.40 m. The bar is being used to lift one edge of a concrete slab S. A stone, placed 0.20 m from one end of B, acts as a pivot. A force of 40 N pushing down at the other end of B is just enough to lift the slab and hold it as shown.

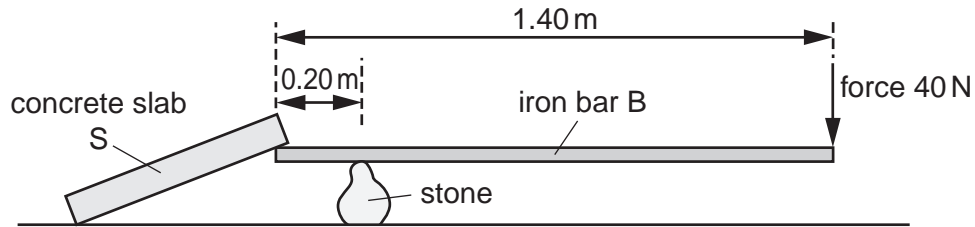

**Fig. 3.1**

(i) On Fig. 3.1, draw an arrow to show the weight of bar B acting from its centre of mass. [1]

(ii) State the distance  $d$  of the centre of mass of bar B from the pivot.

$d =$  .....[1]

(iii) Calculate the total clockwise moment, about the pivot, of the forces acting on bar B.

total clockwise moment = .....[3]



(iv) Calculate the downward force which the slab S exerts on the end of bar B.

force = .....[2]

(v) Suggest a change to the arrangement in Fig. 3.1 that would reduce the force required to lift the slab.

.....

.....[1]

[Total: 9]