



EXAM PAPERS PRACTICE

Reproduction

Level: GCSE AQA 8461

Subject: Biology

Exam Board: Suitable for all boards

Topic: Reproduction

Level: Hard

This is to be used by all students preparing for AQA Biology 8461 foundation or higher tier but it is also suitable for students of other boards



EXAM PAPERS PRACTICE

For more help please visit <https://www.exampaperspractice.co.uk/>

Q1. CADASIL is an inherited disorder caused by a dominant allele.

CADASIL leads to weakening of blood vessels in the brain.

The diagram shows the inheritance of CADASIL in one family.

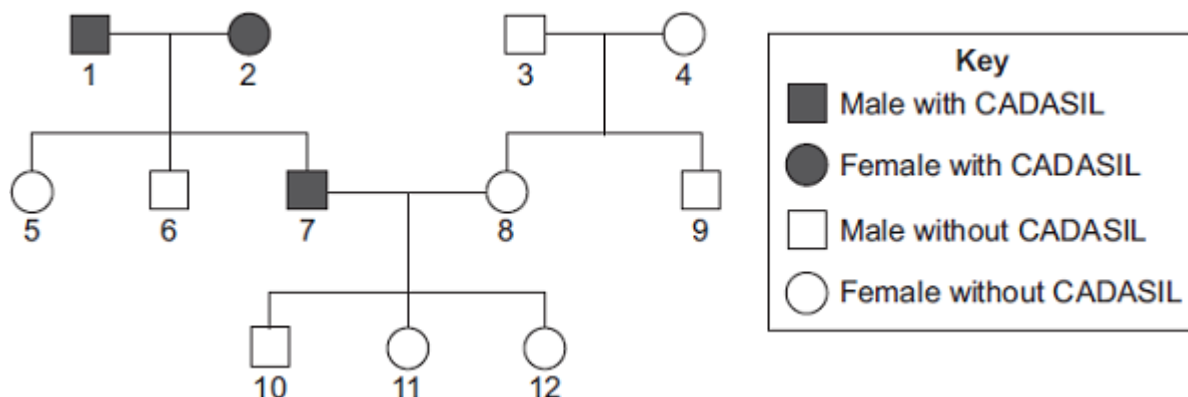

(a) CADASIL is caused by a *dominant allele*.

(i) What is a *dominant allele*?

.....
.....

(1)

(ii) What is the evidence in the diagram that CADASIL is caused by a dominant allele?

.....
.....

(1)

(iii) Person 7 has CADASIL.

Is person 7 homozygous or heterozygous for the CADASIL allele?

Give evidence for your answer from the diagram.

.....
.....

(1)



EXAM PAPERS PRACTICE

For more help please visit <https://www.exampaperspractice.co.uk/>

- (b) Persons **7** and **8** are planning to have another baby.
Use a genetic diagram to find the probability that the new baby will develop into a person with CADASIL.

Use the following symbols to represent alleles.

D = allele for CADASIL

d = allele for not having CADASIL

Probability =

(4)

- (c) Scientists are trying to develop a treatment for CADASIL using stem cells.
Specially treated stem cells would be injected into the damaged part of the brain.

- (i) Why do the scientists use stem cells?

.....
.....
.....
.....

(2)

- (ii) Embryonic stem cells can be obtained by removing a few cells from a human embryo. In 2006, scientists in Japan discovered how to change adult skin cells into stem cells. Suggest **one** advantage of using stem cells from adult skin cells.

.....
.....

(1)

(Total 10 marks)



EXAM PAPERS PRACTICE

For more help please visit <https://www.exampaperspractice.co.uk/>

Q2. Diagram 1 shows a cell from the pancreas.

Diagram 2 shows part of the cell seen under an electron microscope.

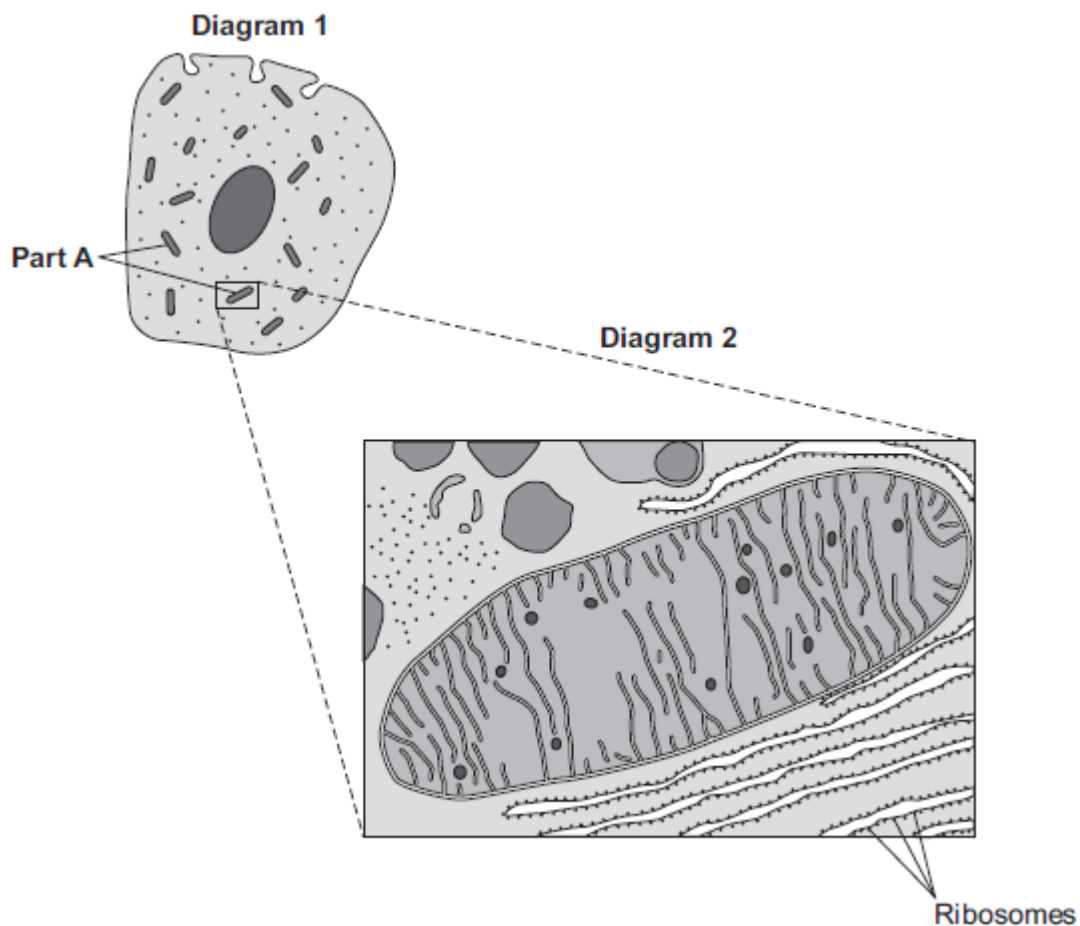

Part **A** is where most of the reactions of aerobic respiration happen.

(a) (i) Name part **A**.

.....

(1)

(ii) Complete the equation for aerobic respiration.

glucose + oxygen \longrightarrow + (+ energy)

(2)

(iii) Part **A** uses oxygen.



EXAM PAPERS PRACTICE

For more help please visit <https://www.exampaperspractice.co.uk/>

Explain how oxygen passes from the blood to part **A**.

.....

.....

.....

.....

.....

.....

.....

.....

.....

(3)

(b) The pancreas cell makes enzymes.

Enzymes are proteins.

Describe how the ribosomes and part **A** help the cell to make enzymes.

.....

.....

.....

.....

.....

.....

.....

.....

.....

(3)

(Total 9 marks)



EXAM PAPERS PRACTICE

For more help please visit <https://www.exampaperspractice.co.uk/>

Q3. In 1866, Gregor Mendel published the results of his investigations into inheritance in garden pea plants.

The diagram below shows the results Mendel obtained in one investigation with purple-flowered and white-flowered pea plants.

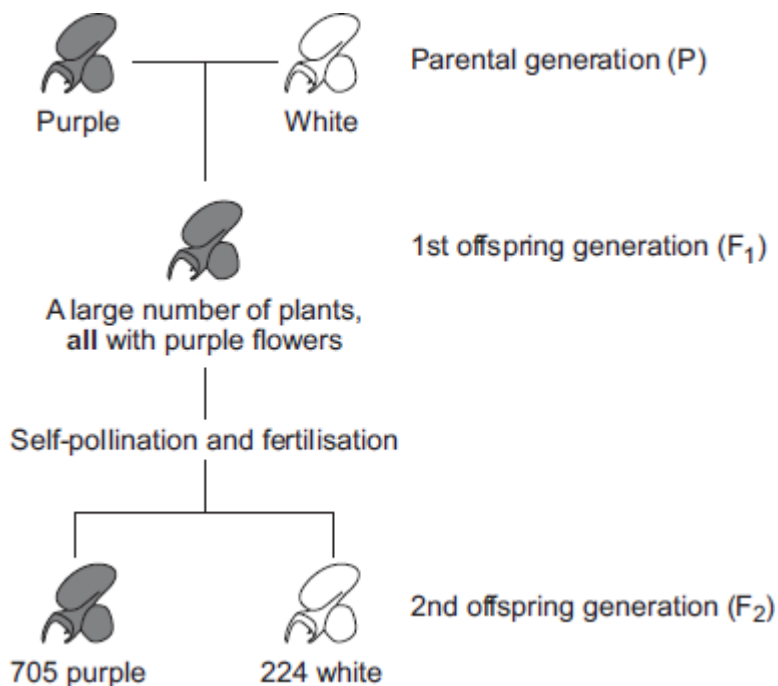

- (a) (i) Calculate the ratio of purple-flowered plants to white-flowered plants in the F₂ generation.

Ratio of purple : white =

(1)

- (ii) There was a total of 929 plants in the F₂ generation.

Mendel thought that the production of a large number of offspring plants improved the investigation.

Explain why.

.....

.....

.....

.....

(2)



EXAM PAPERS PRACTICE

For more help please visit <https://www.exampaperspractice.co.uk/>

- (b) (i) Some of the plants in the diagram are homozygous for flower colour and some are heterozygous.

Complete the table to show whether each of the plants is homozygous or heterozygous. For each plant, tick (✓) **one** box.

	Homozygous	Heterozygous
Purple-flowered plant in the P generation		
White-flowered plant in the P generation		
Purple-flowered plant in the F ₁ generation		

(2)

- (ii) Draw a genetic diagram to show how self-pollination of the F₁ purple-flowered plants produced mainly purple-flowered offspring in the F₂ generation together with some white-flowered offspring.

Use the following symbols:

N = allele for purple flower colour

n = allele for white flower colour

(3)

- (c) When Mendel published his work on genetics, other scientists at the time did not realise how important it was.

Suggest **two** reasons why.

1.....

.....

2.....

.....

(2)
(Total 10 marks)



EXAM PAPERS PRACTICE

For more help please visit <https://www.exampaperspractice.co.uk/>

Q4. Read the information.

Insects can be both useful and harmful to crop plants.
Insects such as bees pollinate the flowers of some crop plants. Pollination is needed for successful sexual reproduction of crop plants.
Some insects eat crops and other insects eat the insects that eat crops.

Corn borers are insects that eat maize plants.
A toxin produced by the bacterium *Bacillus thuringiensis* kills insects.
Scientists grow *Bacillus thuringiensis* in large containers. The toxin is collected from the containers and is sprayed over maize crops to kill corn borers.

A company has developed genetically modified (GM) maize plants. GM maize plants contain a gene from *Bacillus thuringiensis*. This gene changes the GM maize plants so that they produce the toxin.

- (a) Describe how scientists can transfer the gene from *Bacillus thuringiensis* to maize plants.

.....

.....

.....

.....

.....

.....

.....

(3)

- (b) Would you advise farmers to grow GM maize plants?

Justify your answer by giving advantages and disadvantages of growing GM maize plants.

Use the information from the box and your own knowledge to help you.

.....

.....

.....

.....



EXAM PAPERS PRACTICE

For more help please visit <https://www.exampaperspractice.co.uk/>

.....

.....

.....

.....

.....

.....

.....

.....

.....

(4)
(Total 7 marks)



EXAM PAPERS PRACTICE

For more help please visit <https://www.exampaperspractice.co.uk/>

Q5. **Figure 1** shows an image of a small section of DNA.

Figure 2 shows the structure of a small section of DNA.

Figure 1



© Svisio/iStock/Thinkstock

Figure 2

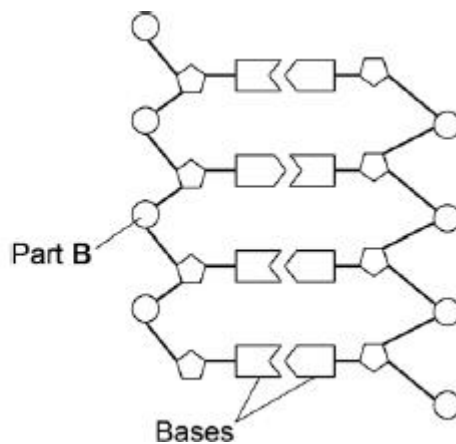

(a) What is **Part B**?

.....
.....

(1)

(b) In **Figure 1** the structure of DNA shows four different bases.

There are four different bases and they always pair up in the same pairs.

Which bases pair up together?

.....

(1)

(c) Syndrome H is an inherited condition.

People with syndrome H do **not** produce the enzyme IDUA.

Figure 3 shows part of the gene coding for the enzyme IDUA.

Figure 3



EXAM PAPERS PRACTICE

For more help please visit <https://www.exampaperspractice.co.uk/>

C T C A T T C A G C T C Strand **J** from a person **without** syndrome H

C T C A T T T A G C T C Strand **K** from a person **with** syndrome H

Strand **K** shows a mutation in the DNA which has caused syndrome H.

The enzyme IDUA helps to break down a carbohydrate in the human body.

The enzyme IDUA produced from Strand **K** will not work.

Explain how the mutation could cause the enzyme **not** to work.

.....

.....

.....

.....

.....

.....

.....

.....

.....

.....

(5)

(d) A recessive allele causes syndrome H.

A heterozygous woman and a homozygous recessive man want to have a child.

Draw a Punnett square diagram to determine the probability of the child having syndrome H.

Identify any children with syndrome H.

Use the following symbols:

A = dominant allele

a = recessive allele

Probability = %

(5)



EXAM PAPERS PRACTICE

For more help please visit <https://www.exampaperspractice.co.uk/>

(Total 12 marks)

Q6. The diagram shows one method of producing herbicide-resistant crop plants.

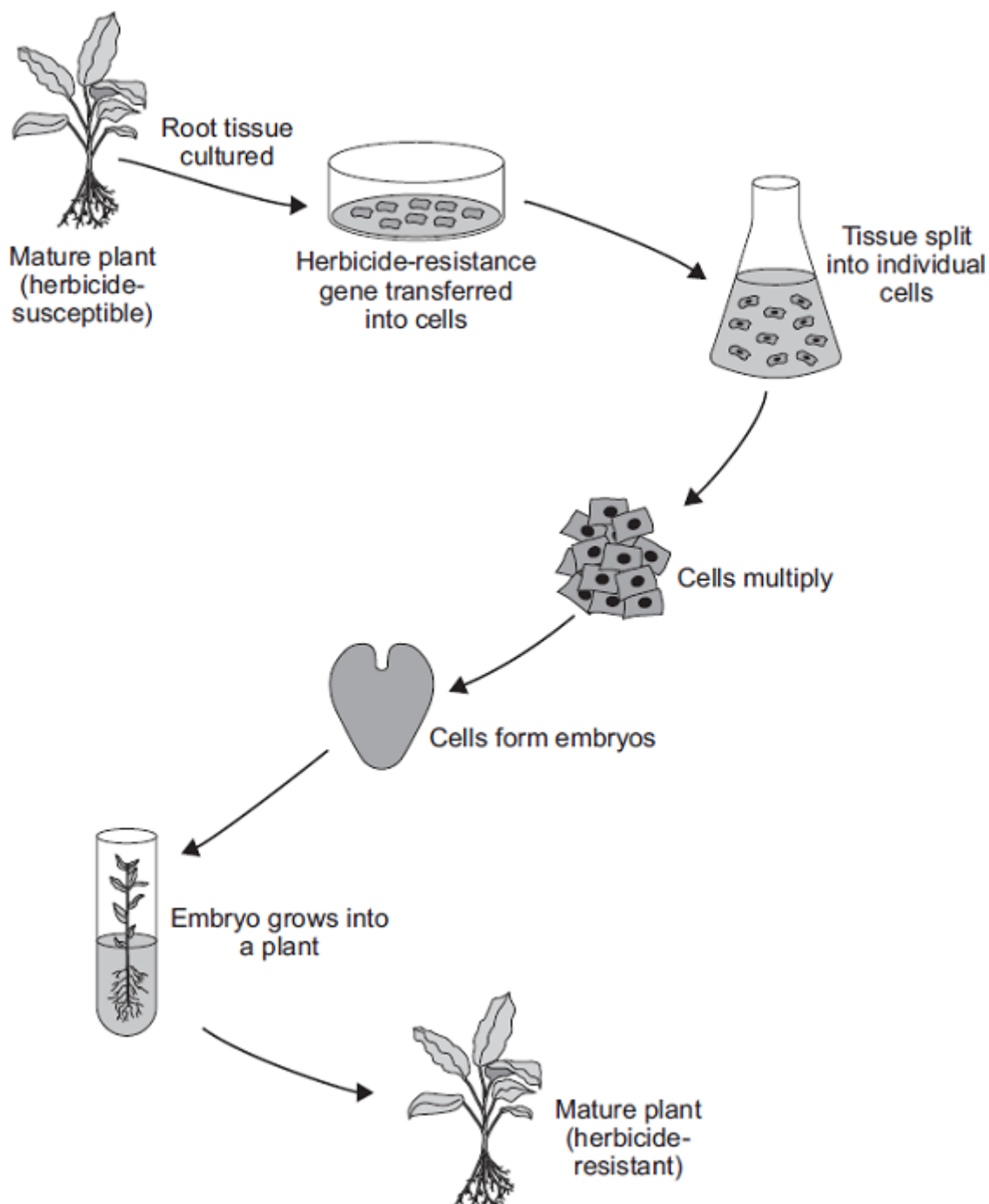

- (a) The herbicide-resistance gene is cut out of a chromosome of a herbicide-resistant plant.

How is the herbicide-resistance gene cut out of the chromosome?

.....



EXAM PAPERS PRACTICE

For more help please visit <https://www.exampaperspractice.co.uk/>

.....

(1)

- (b) Apart from having the herbicide-resistance gene, the herbicide-resistant plants are identical to the herbicide-susceptible plants.

Explain why.

.....
.....
.....
.....

(2)

- (c) Suggest **one** advantage to a farmer of growing herbicide-resistant crops.

.....
.....

(1)

- (d) Many people are opposed to the growing of herbicide-resistant crops produced in this way.

Suggest **one** reason why.

.....
.....

(1)

(Total 5 marks)