

© International Baccalaureate Organization 2025

All rights reserved. No part of this product may be reproduced in any form or by any electronic or mechanical means, including information storage and retrieval systems, without the prior written permission from the IB. Additionally, the license tied with this product prohibits use of any selected files or extracts from this product. Use by third parties, including but not limited to publishers, private teachers, tutoring or study services, preparatory schools, vendors operating curriculum mapping services or teacher resource digital platforms and app developers, whether fee-covered or not, is prohibited and is a criminal offense.

More information on how to request written permission in the form of a license can be obtained from <https://ibo.org/become-an-ib-school/ib-publishing/licensing/applying-for-a-license/>.

© Organisation du Baccalauréat International 2025

Tous droits réservés. Aucune partie de ce produit ne peut être reproduite sous quelque forme ni par quelque moyen que ce soit, électronique ou mécanique, y compris des systèmes de stockage et de récupération d'informations, sans l'autorisation écrite préalable de l'IB. De plus, la licence associée à ce produit interdit toute utilisation de tout fichier ou extrait sélectionné dans ce produit. L'utilisation par des tiers, y compris, sans toutefois s'y limiter, des éditeurs, des professeurs particuliers, des services de tutorat ou d'aide aux études, des établissements de préparation à l'enseignement supérieur, des fournisseurs de services de planification des programmes d'études, des gestionnaires de plateformes pédagogiques en ligne, et des développeurs d'applications, moyennant paiement ou non, est interdite et constitue une infraction pénale.

Pour plus d'informations sur la procédure à suivre pour obtenir une autorisation écrite sous la forme d'une licence, rendez-vous à l'adresse <https://ibo.org/become-an-ib-school/ib-publishing/licensing/applying-for-a-license/>.

© Organización del Bachillerato Internacional, 2025

Todos los derechos reservados. No se podrá reproducir ninguna parte de este producto de ninguna forma ni por ningún medio electrónico o mecánico, incluidos los sistemas de almacenamiento y recuperación de información, sin la previa autorización por escrito del IB. Además, la licencia vinculada a este producto prohíbe el uso de todo archivo o fragmento seleccionado de este producto. El uso por parte de terceros —lo que incluye, a título enunciativo, editoriales, profesores particulares, servicios de apoyo académico o ayuda para el estudio, colegios preparatorios, desarrolladores de aplicaciones y entidades que presten servicios de planificación curricular u ofrezcan recursos para docentes mediante plataformas digitales—, ya sea incluido en tasas o no, está prohibido y constituye un delito.

En este enlace encontrará más información sobre cómo solicitar una autorización por escrito en forma de licencia: <https://ibo.org/become-an-ib-school/ib-publishing/licensing/applying-for-a-license/>.

Chemistry

Higher level

Paper 1A

31 October 2025

Zone A afternoon | Zone B afternoon | Zone C afternoon

2 hours [Paper 1A and Paper 1B]

Instructions to candidates

- Do not open this examination paper until instructed to do so.
- Answer all questions.
- For each question, choose the answer you consider to be the best and indicate your choice on the answer sheet provided.
- A calculator is required for this paper.
- A clean copy of the **chemistry data booklet** is required for this paper.
- The maximum mark for paper 1A is **[40 marks]**.
- The maximum mark for paper 1A and paper 1B is **[75 marks]**.

Section A

1. Which methods for separating the given mixtures into their components are correct?

	Mixture	Method
I.	A mixture of solid in a liquid in which solubility of the solid varies with temperature	Crystallization
II.	A mixture of a solid in a liquid in which the solid is not dissolved	Filtration
III.	A mixture of two miscible liquids with different boiling points	Distillation

- A. I and II only
 B. I and III only
 C. II and III only
 D. I, II and III
2. Chlorine is a diatomic molecule that contains 75% of ^{35}Cl and 25% of ^{37}Cl .

Which graph shows the full mass spectrum of chlorine?

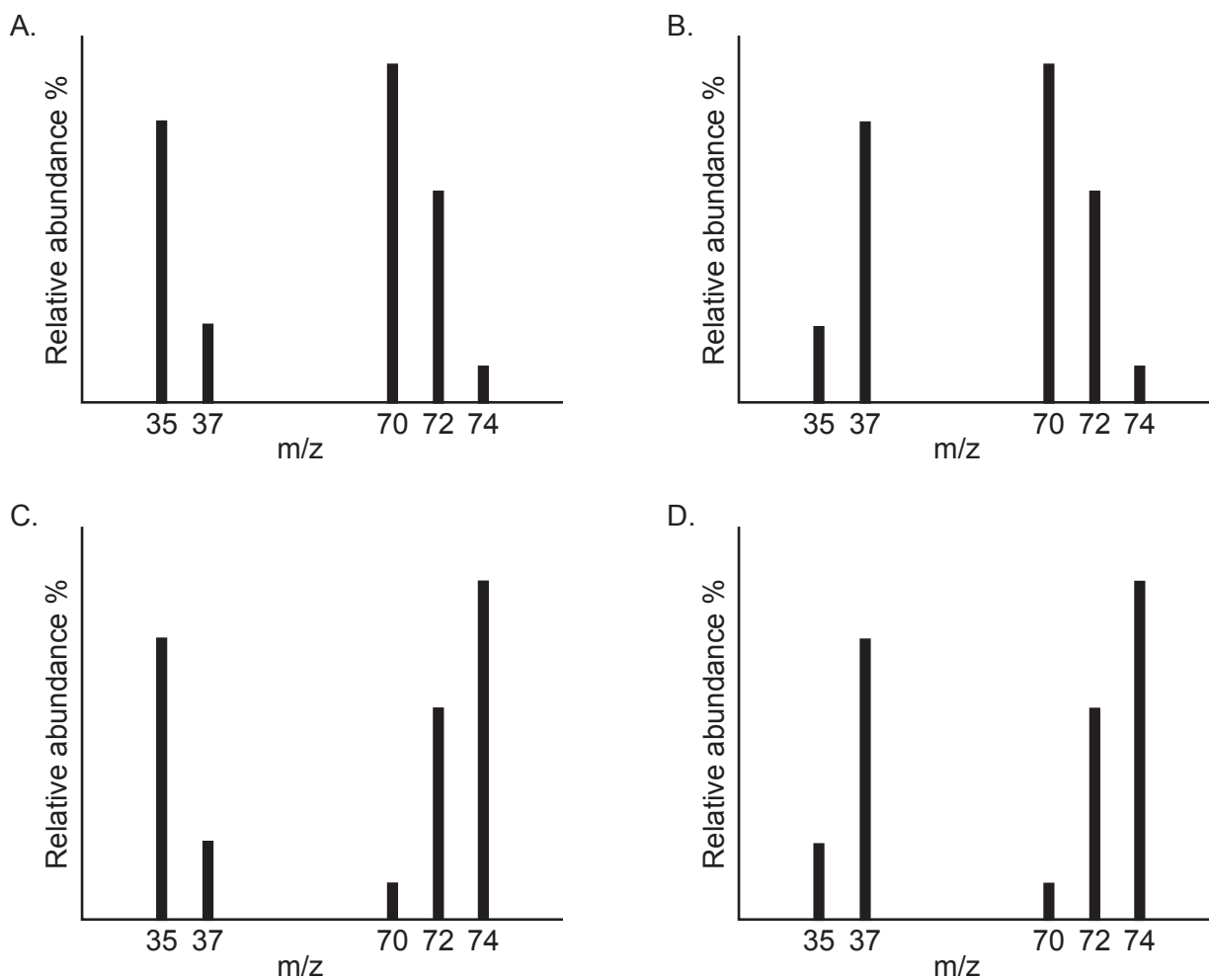

3. Which orbital diagram represents a correct ground state electron configuration based on the Pauli exclusion principle and Hund's rule?

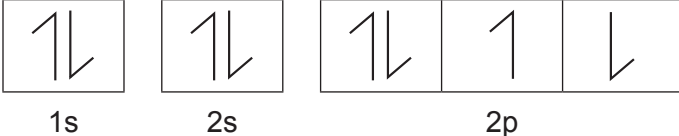
A. 

 1s 2s 2p

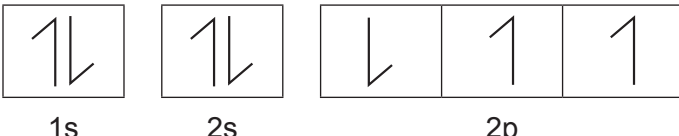
B. 

 1s 2s 2p

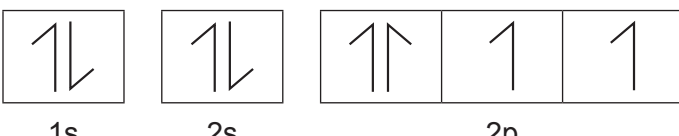
C. 

 1s 2s 2p

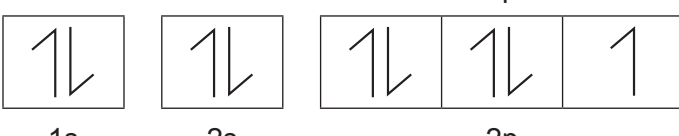
D. 

 1s 2s 2p

4. 5.72 g of $\text{Na}_2\text{CO}_3 \cdot 10\text{H}_2\text{O}$ ($M_r = 286 \text{ g mol}^{-1}$) is dissolved in water to prepare 0.4 dm^3 of aqueous solution.

What is the concentration of sodium ions, in mol dm^{-3} , in the resulting solution?

- A. 0.02
- B. 0.04
- C. 0.05
- D. 0.10
5. In which of the following sets of conditions does the gas exhibit behaviour closest to an ideal gas ?

	Gas	Pressure / kPa	Temperature / K
A.	H_2	100	273
B.	NH_3	50	473
C.	H_2	50	473
D.	NH_3	100	273

6. An expanded view of the NaCl lattice is given in the figure.

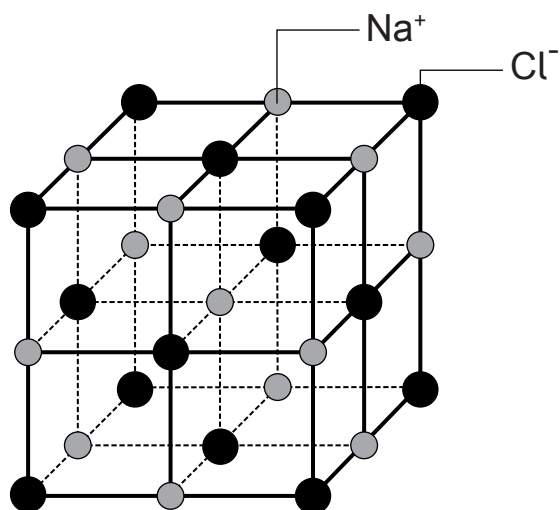

Which statement is correct for the lattice structure of NaCl?

- A. The ions are held together in the lattice by covalent bonds.
- B. The forces of attraction in the lattice are very weak.
- C. Each sodium ion is surrounded by four chloride ions.
- D. The structure breaks apart when dissolved in water.
7. What are the electron domain and molecular geometries of IF_4^+ ion?

	Electron domain geometry	Molecular geometry
A.	Trigonal bipyramidal	Seesaw
B.	Tetrahedral	Tetrahedral
C.	Tetrahedral	Seesaw
D.	Trigonal bipyramidal	Tetrahedral

8. Which orbitals overlap to form σ -bond and π -bond between carbon and oxygen in methanal?

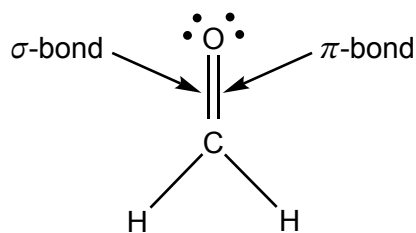

	σ -bond	π -bond
A.	sp^2 and sp^3	p and p
B.	sp^2 and sp^2	p and sp^2
C.	sp^2 and sp^2	p and p
D.	sp^2 and sp^3	p and sp^2

9. Which species contain a coordination bond?

- I. O_3
 - II. CO_2
 - III. NO_3^-
- A. I and II only
 - B. I and III only
 - C. II and III only
 - D. I, II and III

10. What is the preferred Lewis formula for chlorate(VII), ClO_4^- , ion based on formal charges?

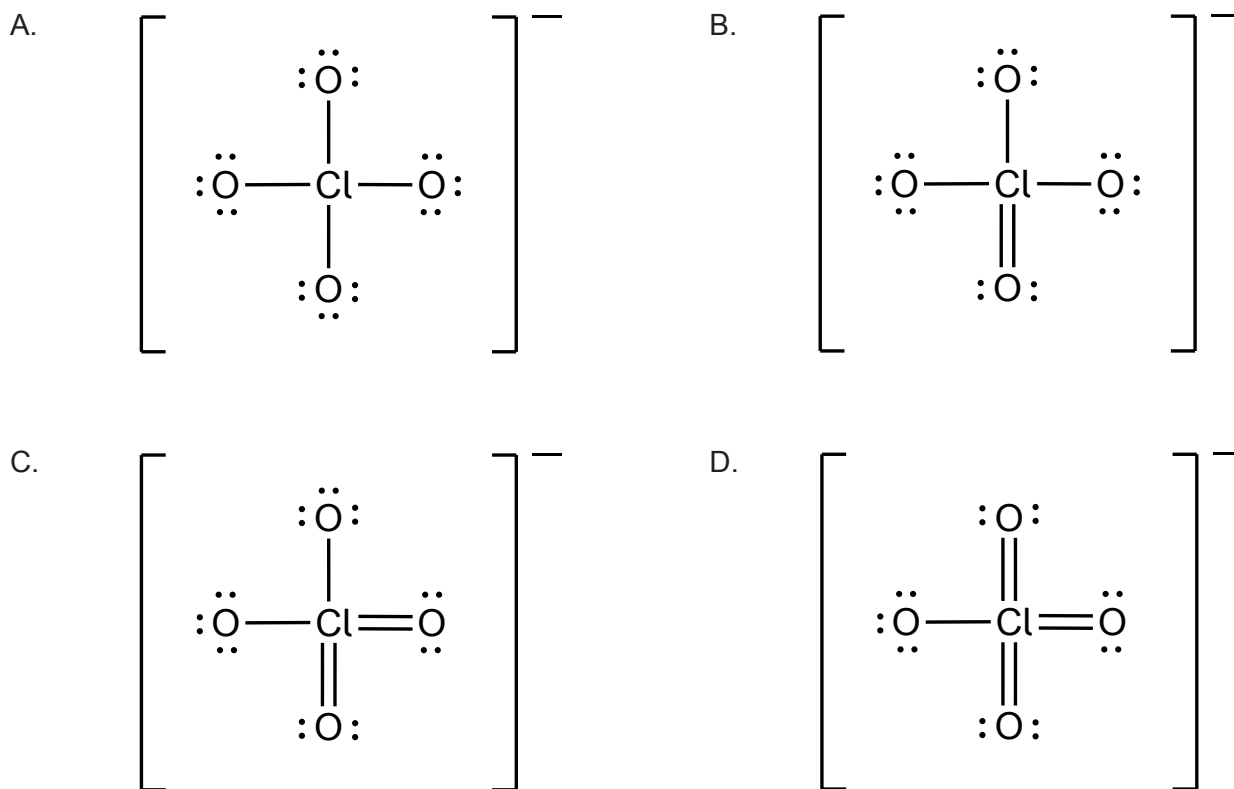

11. Which statement best explains the malleability of magnesium metal?

- A. The metal lattice is held together by the attraction between magnesium ions.
- B. The outer shell electrons of magnesium are free to move.
- C. The layers of magnesium ions can slide relative to each other.
- D. There are strong attractions between the magnesium ions and the free moving electrons.

12. Which material is a good electrical conductor?

- A. Diamond
- B. Graphite
- C. Fullerene
- D. Silicon

13. What is the IUPAC name of the molecule below?

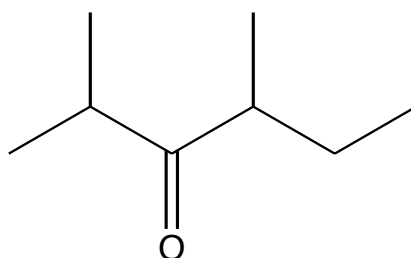

- A. 2-ethyl-4-methylpentan-3-one
B. 4-ethyl-2-methylpentan-3-one
C. 2,4-dimethylhexan-3-one
D. 3,5-dimethylhexan-4-one
14. What are the oxidation states of the elements in Na_2CrO_4 ?

	Sodium	Chromium	Oxygen
A.	+1	+6	-1
B.	+2	+3	-1
C.	+1	+6	-2
D.	+2	+3	-2

15. Which statement is correct for the group 17 elements from fluorine to iodine?
- A. The elements become more volatile.
B. The hydrides of the elements become more acidic.
C. The elements become more reactive.
D. The bond between the halogen atoms becomes less polar.

16. Which aqueous solution of an ion is likely to be coloured based on the electron configuration of that ion?

- A. Ni^{2+}
- B. Sc^{3+}
- C. Cu^+
- D. Zn^{2+}

17. Which molecule contains a chiral centre?

- A. $\text{CH}_3\text{CH}(\text{CH}_3)\text{CHO}$
- B. $\text{CH}_3\text{CHClCH}_2\text{CH}_3$
- C. $\text{CH}_3\text{C}(\text{CH}_3)_2\text{OH}$
- D. $\text{ClCH}_2\text{CH}_2\text{COOH}$

18. What is the low-resolution ^1H NMR spectrum of ethanal?

A.

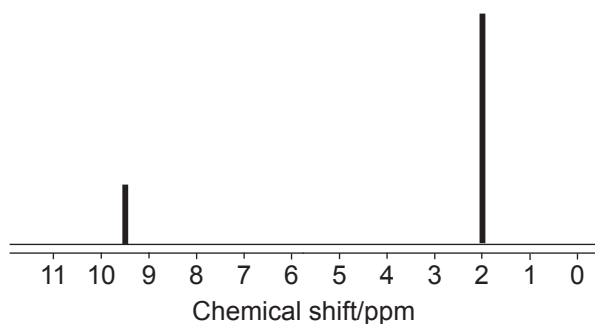

B.

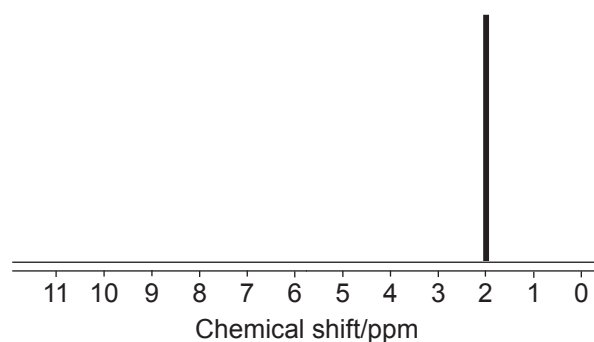

C.

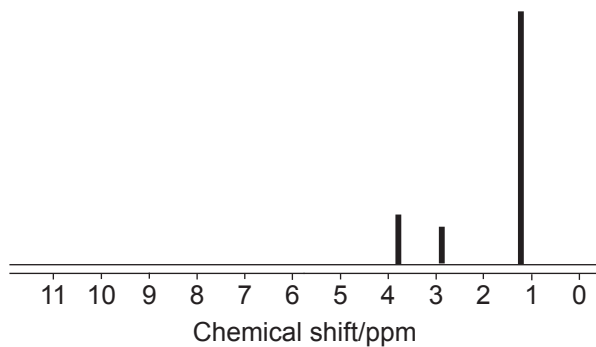

D.

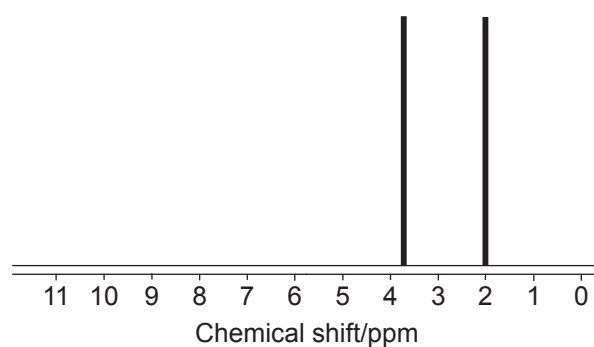

19. Which pair of compounds represents the correct type of isomerism?

Type of isomerism	Pair of compounds
A. Chain	$\text{H}_3\text{C}-\text{CH}_2-\text{CH}_2-\text{CH}_3$ and $\begin{array}{c} \text{CH}_3 \\ \\ \text{H}_2\text{C}-\text{CH}_2 \\ \\ \text{CH}_3 \end{array}$
B. Functional group	$\text{H}_3\text{C}-\text{O}-\text{CH}_2-\text{CH}_2-\text{CH}_3$ and $\begin{array}{c} \text{OH} \\ \\ \text{H}_3\text{C}-\text{CH}-\text{CH}_2-\text{CH}_3 \end{array}$
C. Positional	$\text{H}_3\text{C}-\text{O}-\overset{\text{O}}{\parallel}{\text{C}}-\text{CH}_2-\text{CH}_3$ and $\text{H}-\text{O}-\overset{\text{O}}{\parallel}{\text{C}}-\text{CH}_2-\text{CH}_2-\text{CH}_3$
D. <i>Cis-trans</i>	$\begin{array}{c} \text{H} \quad \text{H} \\ \diagdown \quad / \\ \text{C}=\text{C} \\ / \quad \diagdown \\ \text{H}_3\text{C} \quad \text{CH}_3 \end{array}$ and $\begin{array}{c} \text{H}_3\text{C} \quad \text{H} \\ \diagdown \quad / \\ \text{C}=\text{C} \\ / \quad \diagdown \\ \text{H}_3\text{C} \quad \text{H} \end{array}$

20. The potential energy profile of a reaction is shown.

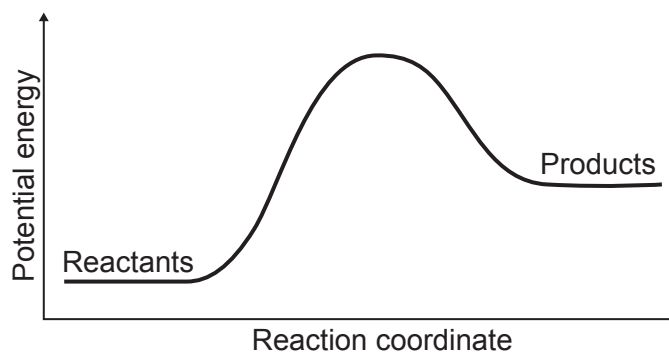

Which reaction has this energy profile?

- A. $\text{N}_2(\text{g}) + \text{O}_2(\text{g}) \rightarrow 2\text{NO}(\text{g})$
- B. $2\text{H}(\text{g}) \rightarrow \text{H}_2(\text{g})$
- C. $\text{NaOH}(\text{aq}) + \text{HCl}(\text{aq}) \rightarrow \text{NaCl}(\text{aq}) + \text{H}_2\text{O}(\text{l})$
- D. $\text{CH}_4(\text{g}) + 2\text{O}_2(\text{g}) \rightarrow \text{CO}_2(\text{g}) + 2\text{H}_2\text{O}(\text{l})$

21. What is the enthalpy change for the reaction in kJ mol^{-1} ?

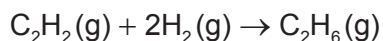

	$\Delta H_c^\theta / \text{kJ mol}^{-1}$
$\text{C}_2\text{H}_2(\text{g})$	-1301
$\text{H}_2(\text{g})$	-286
$\text{C}_2\text{H}_6(\text{g})$	-1561

- A. $-1561 - 2(-286) - 1301$
- B. $-1561 + 2(-286) - 1301$
- C. $-1301 + 2(-286) + 1561$
- D. $-1301 - 2(-286) + 1561$
22. Which equation represents the enthalpy change of atomisation, ΔH_{at}^θ , of bromine?
- A. $\text{Br}_2(\text{l}) \rightarrow \text{Br}_2(\text{g})$
- B. $1/2\text{Br}_2(\text{g}) \rightarrow \text{Br}(\text{g})$
- C. $1/2\text{Br}_2(\text{l}) \rightarrow \text{Br}(\text{g})$
- D. $\text{Br}_2(\text{g}) \rightarrow 2\text{Br}(\text{g})$
23. Which of the following statements best describes an environmental implication associated with the use of fossil fuels?
- A. Increased biodiversity due to the establishment of habitats through mining
- B. Decreased emission of greenhouse gases leading to global cooling
- C. Enhanced soil fertility due to the deposition of coal dust
- D. Acid rain formation from the release of sulfur dioxide and nitrogen oxides

24. Which reaction is predicted to occur with the largest decrease in entropy?

- A. $\text{N}_2(\text{g}) + 3\text{H}_2(\text{g}) \rightarrow 2\text{NH}_3(\text{g})$
- B. $\text{N}_2(\text{g}) + 2\text{O}_2(\text{g}) \rightarrow 2\text{NO}_2(\text{g})$
- C. $6\text{CO}_2(\text{g}) + 6\text{H}_2\text{O}(\text{g}) \rightarrow \text{C}_6\text{H}_{12}\text{O}_6(\text{s}) + 6\text{O}_2(\text{g})$
- D. $\text{CO}(\text{g}) + 2\text{H}_2(\text{g}) \rightarrow \text{CH}_3\text{OH}(\text{l})$

25. Equal volumes of X_2 and Y_2 gases are allowed to react in a sealed container to form XY_3 gas. After completion of the reaction, the volume of XY_3 is measured to be 40 cm^3 .

What was the volume, in cm^3 , of X_2 gas at the beginning?

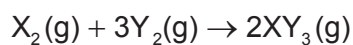

- A. 20
- B. 40
- C. 60
- D. 120

26. What is the volume of nitrogen dioxide, in cm^3 , produced at STP when 1.28 g of copper reacts with excess nitric acid?



Molar volume of an ideal gas at STP is $22.7\text{ dm}^3\text{ mol}^{-1}$

- A. 227
- B. 456
- C. 684
- D. 914

27. The dotted line represents the volume of carbon dioxide evolved when excess calcium carbonate is added into 100 cm^3 of 1.0 mol dm^{-3} of hydrochloric acid.

Which graph represents the production of carbon dioxide when excess calcium carbonate is added to the 200 cm^3 of 0.25 mol dm^{-3} of hydrochloric acid?

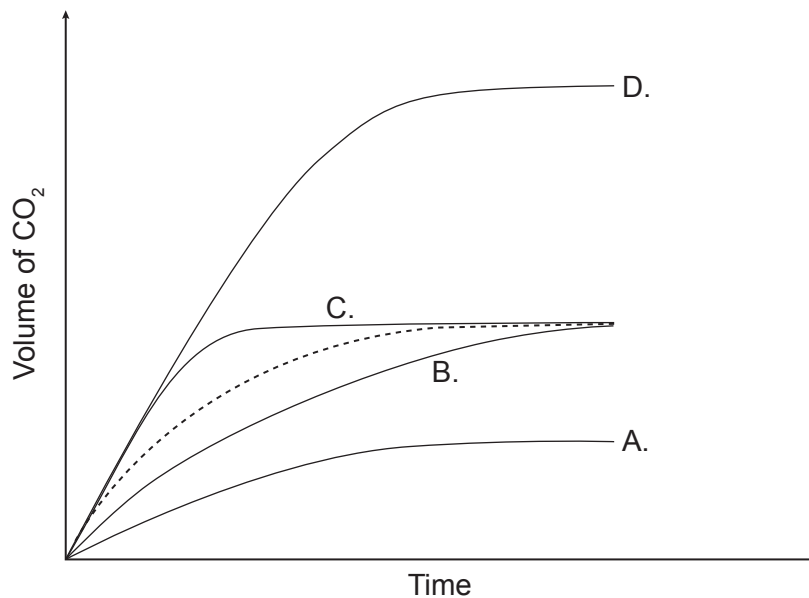

28. Which reaction has the lowest activation energy?

- A. $\text{Cl}_2(\text{g}) \rightarrow 2\text{Cl}(\text{g})$
- B. $\text{HCl}(\text{g}) \rightarrow \text{H}(\text{g}) + \text{Cl}(\text{g})$
- C. $\text{HCl}(\text{g}) \rightarrow \text{H}^+(\text{g}) + \text{Cl}^-(\text{g})$
- D. $2\text{H}(\text{g}) \rightarrow \text{H}_2(\text{g})$

29. Consider the following equation:

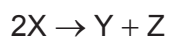

Which graph shows that the reaction is first order with respect to X?

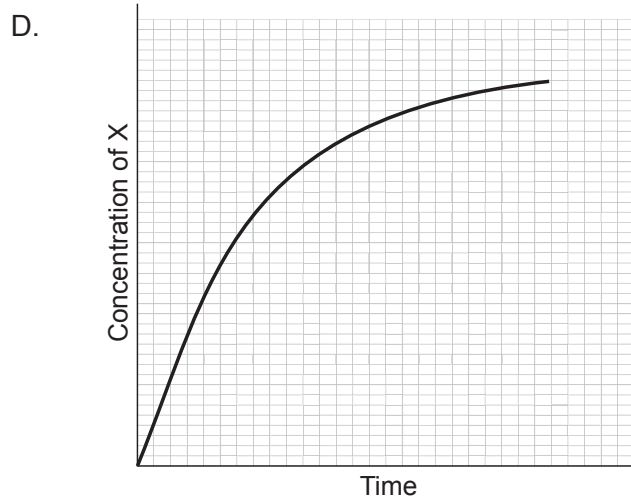
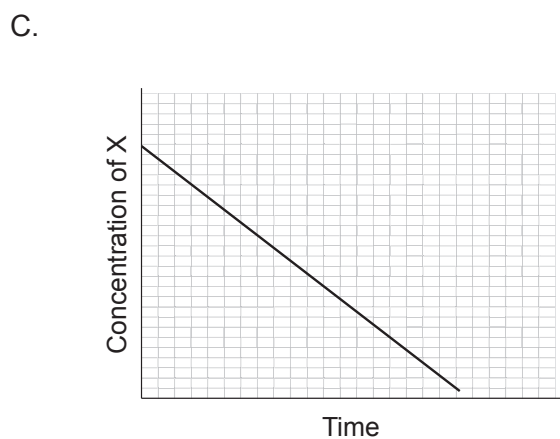
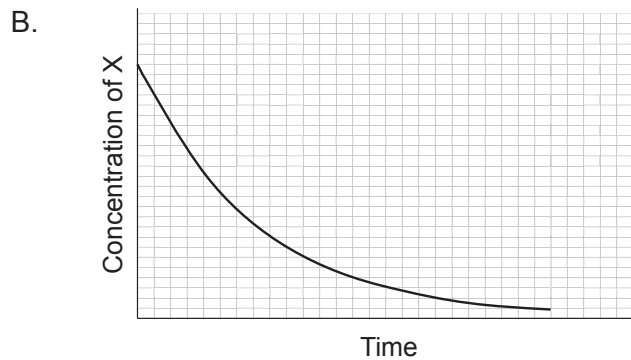
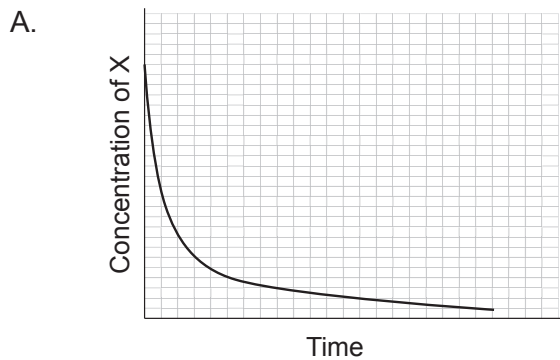

30. Which statement regarding the chemical equilibrium explains why it is described as dynamic?

- A. There is a continuous shift in the equilibrium position.
- B. The reactants and products continue to react.
- C. The concentrations of reactants and products continue to change.
- D. The rates of forward and reverse reactions continue to change.

31. SO_2 reacts with O_2 to produce SO_3 .

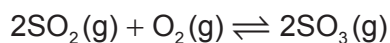

A mixture of 1.10 mol of $\text{SO}_2(\text{g})$ and 1.95 mol of $\text{O}_2(\text{g})$ was placed into a 1 dm^3 container at a certain temperature. When the equilibrium was reached, the mixture contained 0.18 mol of $\text{SO}_2(\text{g})$.

What is the value of the equilibrium constant, K , for this reaction?

- A. $\frac{0.92^2}{0.92^2 \times 0.46}$
- B. $\frac{0.46}{0.18 \times 1.03}$
- C. $\frac{0.92}{0.18 \times 1.49}$
- D. $\frac{0.92^2}{0.18^2 \times 1.49}$
32. In which of the following reactions does ammonia behave as a Brønsted–Lowry base?
- A. $4\text{NH}_3 + 5\text{O}_2 \rightarrow 4\text{NO} + 6\text{H}_2\text{O}$
- B. $\text{NH}_3 + \text{H}_2\text{O} + \text{CO}_2 \rightarrow (\text{NH}_4)\text{HCO}_3$
- C. $\text{NH}_3 + \text{CH}_3\text{CH}_2\text{Cl} \rightarrow \text{CH}_3\text{CH}_2\text{NH}_2 + \text{HCl}$
- D. $2\text{NH}_3 + 2\text{K} \rightarrow 2\text{KNH}_2 + \text{H}_2$
33. Which aqueous solution has the lowest pH?
- A. $0.01 \text{ mol dm}^{-3} \text{NH}_4\text{Cl}$
- B. $0.01 \text{ mol dm}^{-3} \text{NaCl}$
- C. $0.01 \text{ mol dm}^{-3} \text{NH}_4\text{HCO}_3$
- D. $0.01 \text{ mol dm}^{-3} \text{NaHCO}_3$

34. What is the half equation for the reduction of nitric acid to nitrogen(II) oxide in acidic medium?
- A. $\text{HNO}_3 + 3\text{H}^+ + 3\text{e}^- \rightarrow \text{NO} + 2\text{H}_2\text{O}$
- B. $\text{HNO}_3 + 4\text{H}^+ + 4\text{e}^- \rightarrow \text{NO} + 2\text{H}_2\text{O}$
- C. $\text{HNO}_3 + 2\text{H}_2\text{O} \rightarrow \text{NO} + 4\text{H}^+ + 4\text{e}^-$
- D. $\text{HNO}_3 + 2\text{H}_2\text{O} \rightarrow \text{NO} + 3\text{H}^+ + 3\text{e}^-$

35. Which compound undergoes oxidation when heated with acidified potassium dichromate?

- I. $\text{CH}_3\text{CH}_2\text{CH}_2\text{CH}_2\text{OH}$
- II. $\text{CH}_3\text{C}(\text{CH}_3)_2\text{OH}$
- III. $\text{CH}_3\text{CH}(\text{OH})\text{CH}_2\text{CH}_3$

- A. I and II only
- B. I and III only
- C. II and III only
- D. I, II and III
36. A student performed displacement reactions using metals X, Y, Z and solutions of their ions, X^{2+} , Y^{2+} , Z^{2+} . The results are shown.

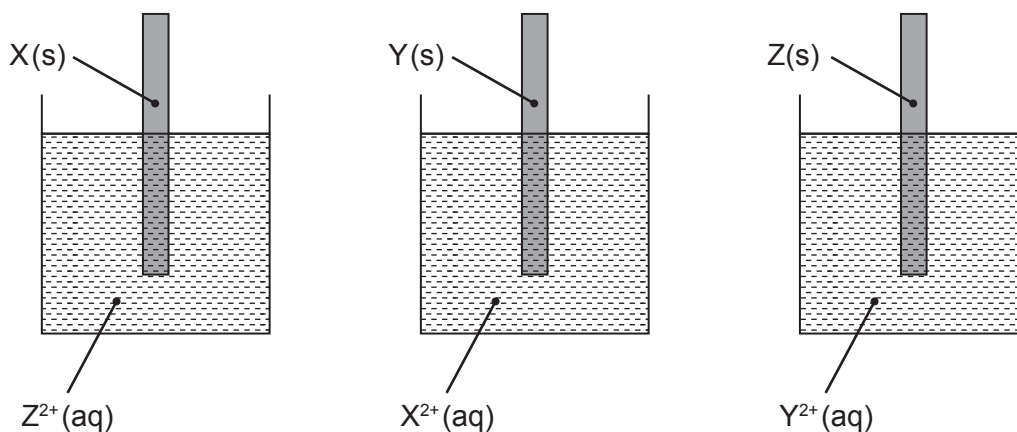

Results: No reaction No reaction Reaction occurs

What is the increasing order of the reactivity of X, Y and Z metals?

- A. X, Y, Z
- B. Y, X, Z
- C. Z, X, Y
- D. Y, Z, X

37. Which radical is most likely to form during the breakdown of one covalent bond of dichlorofluoromethane, CHCl_2F , in the upper atmosphere?

- A. $\cdot\text{CHClF}$
- B. $\cdot\text{CCl}_2\text{F}$
- C. $\cdot\text{CHCl}_2$
- D. $\cdot\text{CHCl}_2\text{F}$

38. But-2-ene undergoes a variety of addition reactions.

Which of the following is correct?

	Reagent added	Product
A.	H_2	But-1-ene
B.	H_2O	Butan-1-ol
C.	HBr	2-bromobutane
D.	Br_2	2,2-dibromobutane

39. Which statements are correct for the complex ion $[\text{FeCl}_4]^{2-}$?

- I. Chloride ions are behaving as ligands.
 - II. The oxidation state of iron is +3.
 - III. Iron ion forms coordination bonds with chloride ions.
- A. I and II only
 - B. I and III only
 - C. II and III only
 - D. I, II and III

40. Which statement is correct about an $\text{S}_{\text{N}}2$ mechanism?

- A. Two molecules are involved in the rate-determining step of the mechanism.
 - B. Two steps are involved in the mechanism.
 - C. A nucleophile is substituted by an electrophile.
 - D. The mechanism involves formation of an intermediate carbocation.
-