

1. A shaded shape is shown on the grid of centimetre squares.

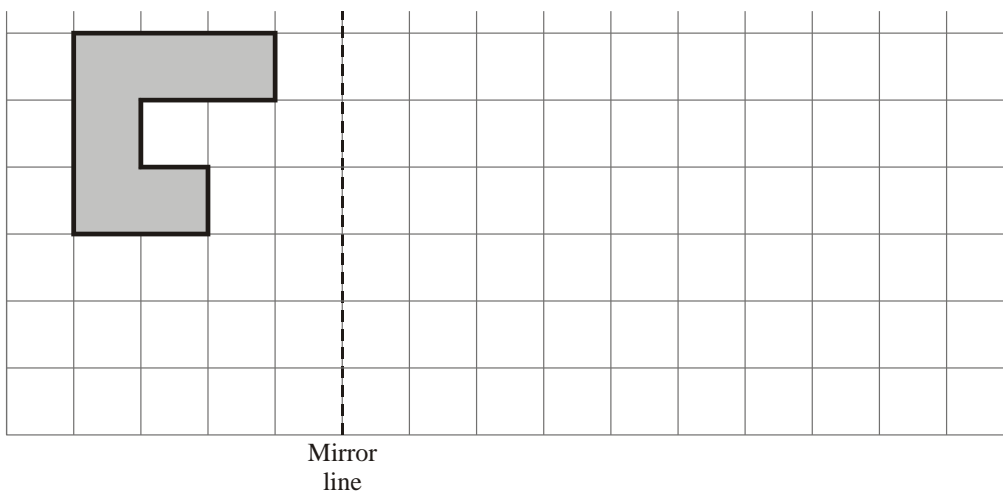

(a) Work out the perimeter of the shaded shape.

.....cm (1)

(b) Work out the area of the shaded shape.

.....cm² (1)

(c) Reflect the shaded shape in the mirror line.

(2)
(4 marks)

2.

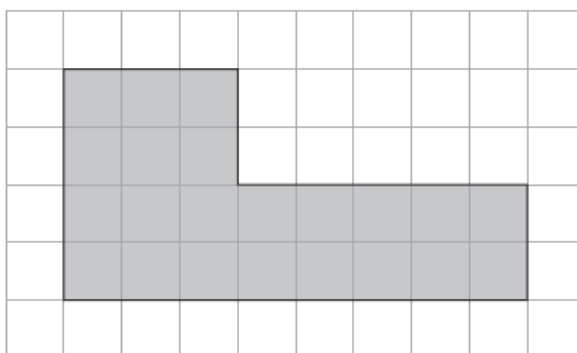

The shaded shape is drawn on a grid of centimetre squares.

(a) Find the perimeter of the shaded shape. cm (1)

(b) Find the area of the shaded shape. cm² (1)

(2 marks)

3.

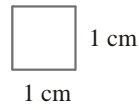
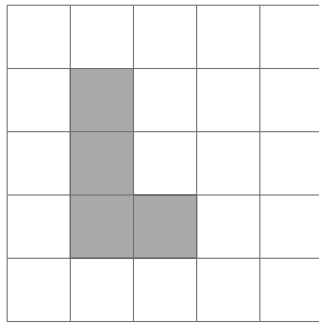

- (a) (i) Find the area of the shaded shape. cm²
- (ii) Find the perimeter of the shaded shape. cm
- (2)**

Here is a solid prism made from centimetre cubes.

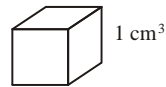
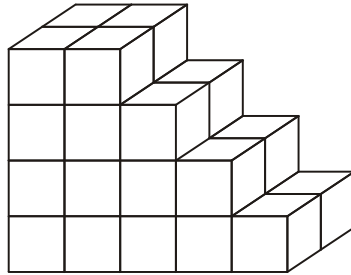

- (b) Find the volume of the solid prism. cm³
- (2)**
-
- (4 marks)**

4.

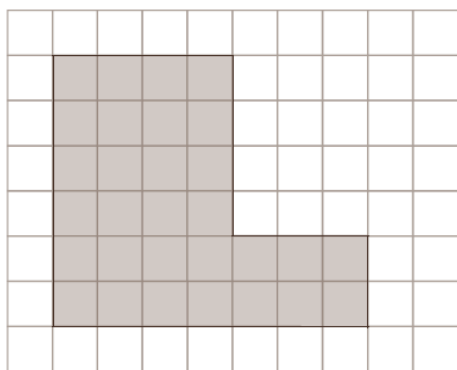

A shaded shape is shown on the grid of centimetre squares.

- (a) Find the perimeter of the shaded shape.cm
- (1)**
- (b) Find the area of the shaded shape.cm²
- (1)**
-
- (2 marks)**

5. A shaded shape has been drawn on a grid of centimetre squares.

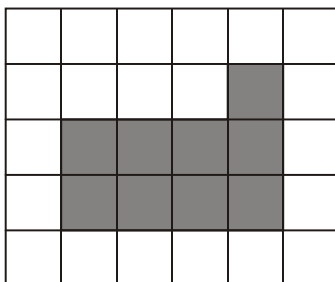

(a) Find the perimeter of the shaded shape.cm (1)

Another shaded shape has been drawn on a grid of centimetre squares.

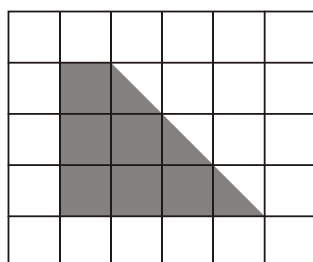

(b) Find the area of the shaded shape. cm² (2)
(3 marks)

6. This shaded shape is drawn on a centimetre grid.

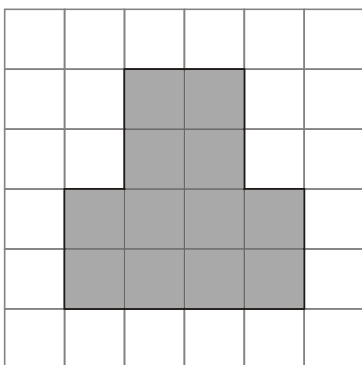

(a) Work out the perimeter of the shaded shape. cm (1)

(b) Work out the area of the shaded shape. cm² (1)
(2 marks)



7.

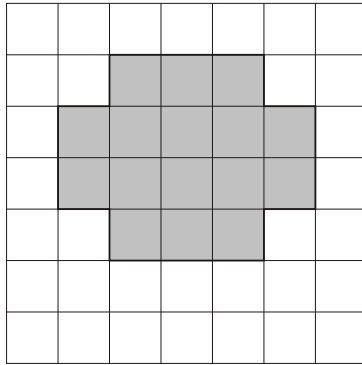

The diagram shows a shaded shape drawn on a centimetre grid.

- (a) Find the area of the shaded shape.
State the units of your answer. (2)
- (b) Find the perimeter of the shaded shape.cm (1)

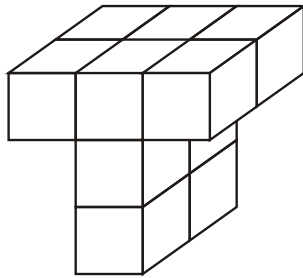

The diagram shows a prism made of centimetre cubes.

- (c) Find the volume of the prism.cm³ (2)
-
- (5 marks)**

8.

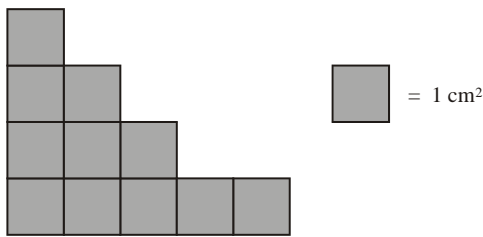

- (a) Find the area of the shape. cm² (1)
 - (b) Find the perimeter of the shape. (2)
-
- (3 marks)**

9.

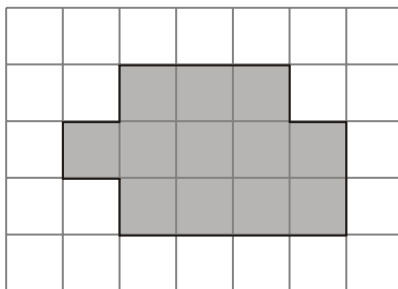

The diagram shows a shaded shape drawn on a centimetre grid.

(a) Work out the perimeter of the shaded shape. cm (1)

(b) Work out the area of the shaded shape.
State the units of your answer. (2)

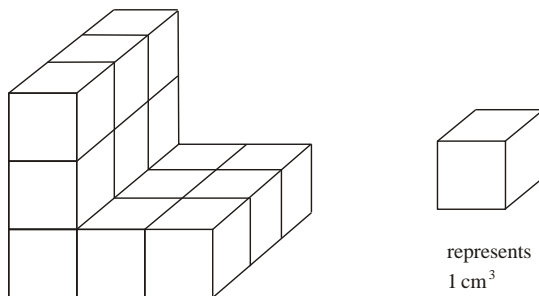

Here is a solid prism made of centimetre cubes.

(c) Find the volume of the solid prism. cm³ (2)

(5 marks)

10. This shaded shape is drawn on a grid of centimetre squares.

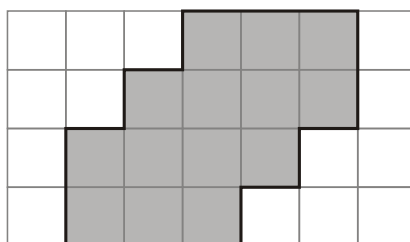

(a) Find the perimeter of the shaded shape. cm (1)

(b) Find the area of the shaded shape. cm² (1)

(2 marks)

11. Here is a shaded shape on a centimetre grid.

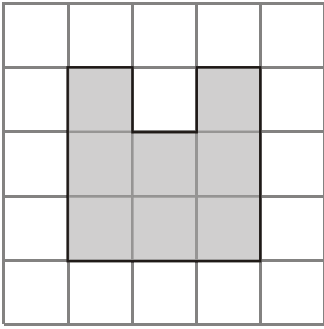

- (a) Find the area of the shaded shape. cm² (1)
- (b) Find the perimeter of the shaded shape. cm (2)

Here is a solid prism made of centimetre cubes.

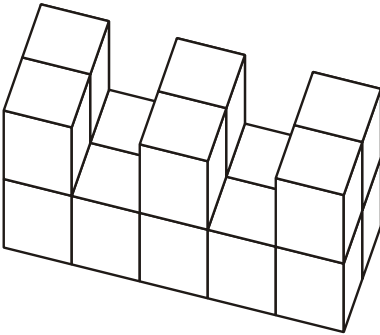

- (c) Find the volume of the solid prism. cm³ (2)
- (5 marks)**
-

12. A shaded shape has been drawn on the centimetre grid.

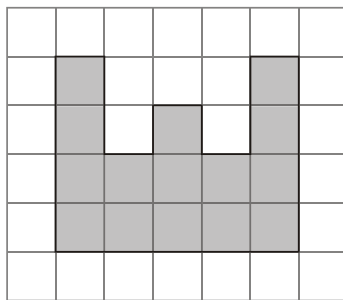

- (a) Find the perimeter of the shaded shape. cm (1)
- (b) Find the area of the shaded shape. cm² (1)
- (2 marks)**
-

13. This shaded shape is drawn on a grid of centimetre squares.

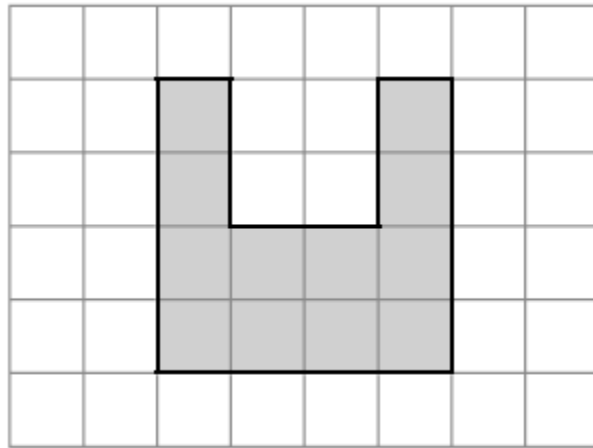

(a) (i) Find the perimeter of the shaded shape.

..... cm

(ii) Find the area of the shaded shape.

..... cm²
(2)

This solid prism is made from centimetre cubes.

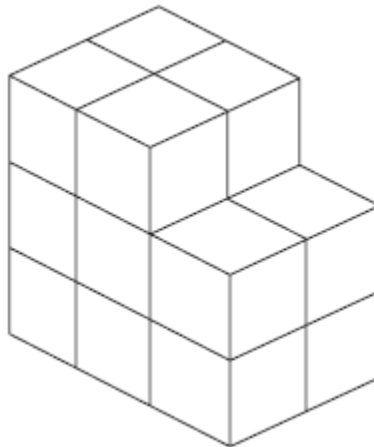

(b) Find the volume of the prism.

..... cm³
(1)

(Total 3 marks)

1. Here are 5 diagrams and 5 labels.
In each diagram the centre of the circle is marked with a cross (×).

Match each diagram to its label.
One has been done for you.

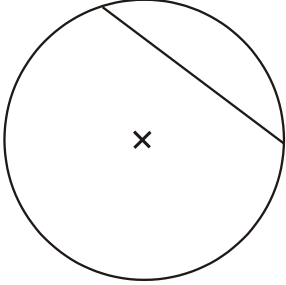
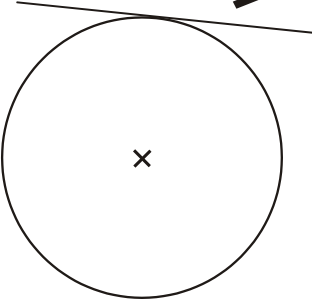
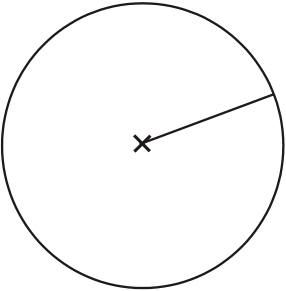
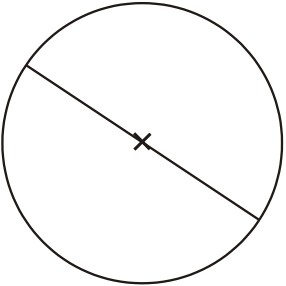
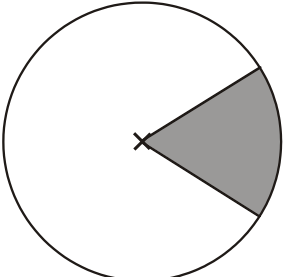
| Diagram | Label |
|---|---|
|  | <div style="border: 1px solid black; padding: 5px; width: fit-content; margin: 0 auto;">Circle and tangent</div> |
|  | <div style="border: 1px solid black; padding: 5px; width: fit-content; margin: 0 auto;">Circle and radius</div> |
|  | <div style="border: 1px solid black; padding: 5px; width: fit-content; margin: 0 auto;">Circle and chord</div> |
|  | <div style="border: 1px solid black; padding: 5px; width: fit-content; margin: 0 auto;">Circle and sector</div> |
|  | <div style="border: 1px solid black; padding: 5px; width: fit-content; margin: 0 auto;">Circle and diameter</div> |

(3 marks)

2. Here are some diagrams relating to a circle.

Draw an arrow from each of the diagrams to its mathematical name.
The arrow showing an arc is drawn for you.

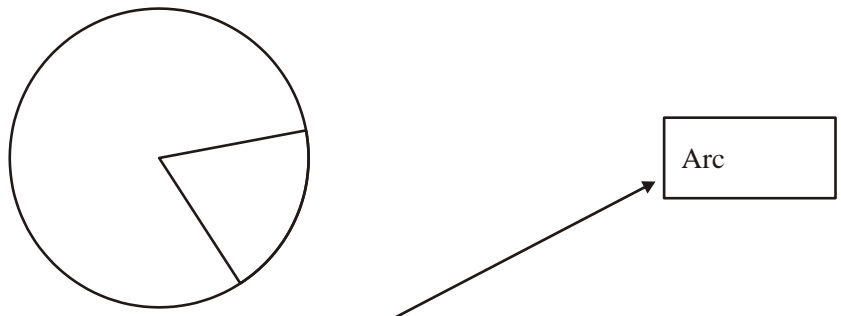

Arc



Circle and diameter

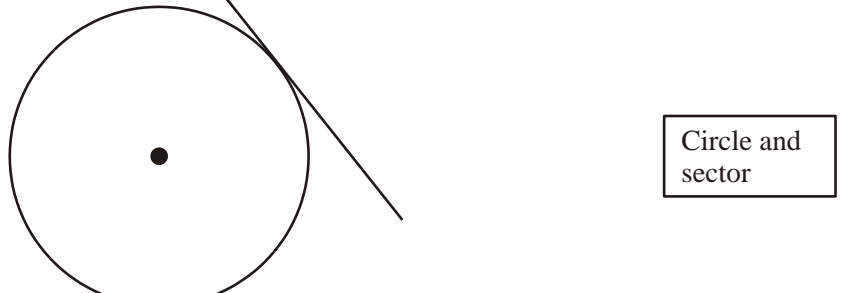

Circle and sector

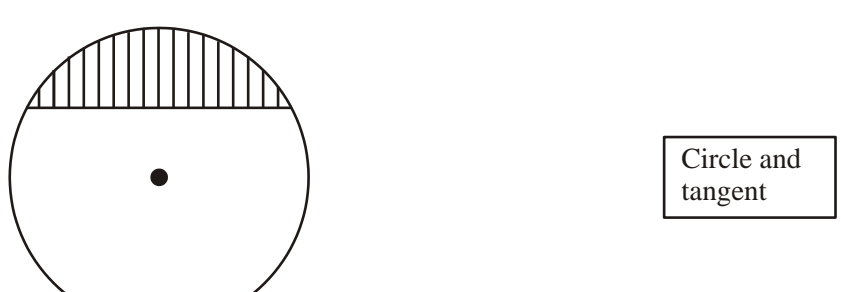

Circle and tangent

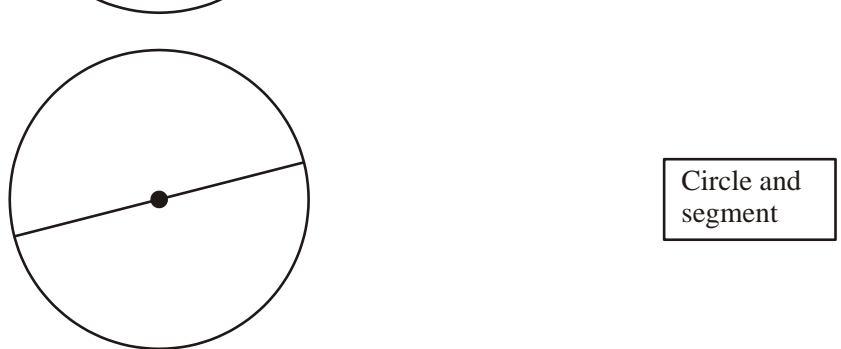

Circle and segment

(3 marks)

3. The radius of a circle is 3.60 m.

Work out the area of the circle.
Give your answer correct to 3 significant figures.

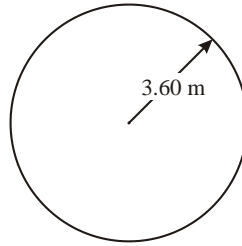

Diagram **NOT**
accurately drawn

.....

(3 marks)

4. The diameter of a wheel on Harry's bicycle is 0.65 m.

Calculate the circumference of the wheel.
Give your answer correct to 2 decimal places.

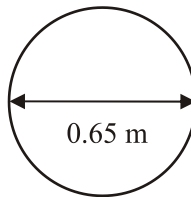

Diagram **NOT**
accurately drawn

.....

(3 marks)

- 5.

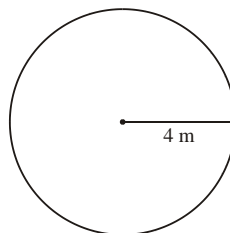

Diagram **NOT**
accurately drawn

The radius of a circle is 4 m.

Work out the area of the circle.
Give your answer correct to 3 significant figures.

.....

(3 marks)

6. A circle has a radius of 6.1 cm.
Work out the circumference of the circle.

Give your answer correct to 3 significant figures.

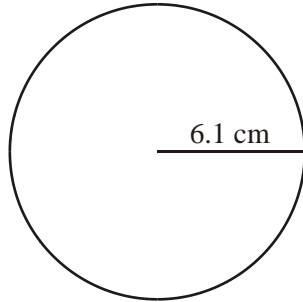

Diagram NOT
accurately drawn

.....

(3 marks)

7. The radius of a circle is 6.4 cm.
Work out the circumference of this circle.

Give your answer correct to 1 decimal place.

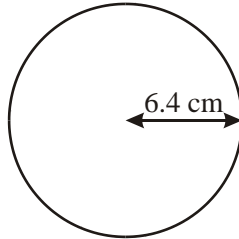

Diagram NOT
accurately drawn

.....

(3 marks)

- 8.

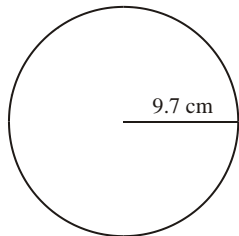

Diagram NOT
accurately drawn

The radius of the circle is 9.7 cm.
Work out the area of the circle.
Give your answer to 3 significant figures.

.....

(3 marks)

9. The diameter of a circle is 12 centimetres.

- (a) Work out the circumference of the circle.
Give your answer, in centimetres, correct to 1 decimal place.

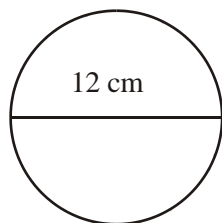

Diagram **NOT**
drawn accurately

.....

(3 marks)

10. Here is a tile in the shape of a semicircle.

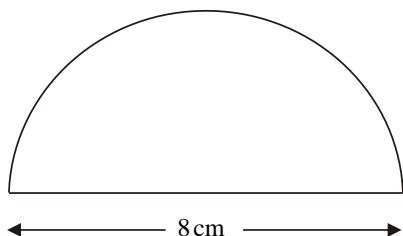

Diagram **NOT**
accurately drawn

The diameter of the semicircle is 8 cm.

Work out the perimeter of the tile.
Give your answer correct to 2 decimal places.

..... cm

(3 marks)

11.

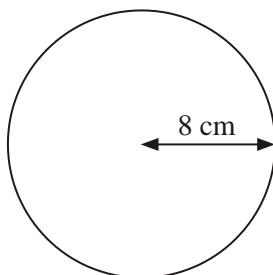

Diagram **NOT**
accurately drawn

The radius of this circle is 8 cm.

Work out the circumference of the circle.
Give your answer correct to 2 decimal places.

..... cm

(3 marks)

12.

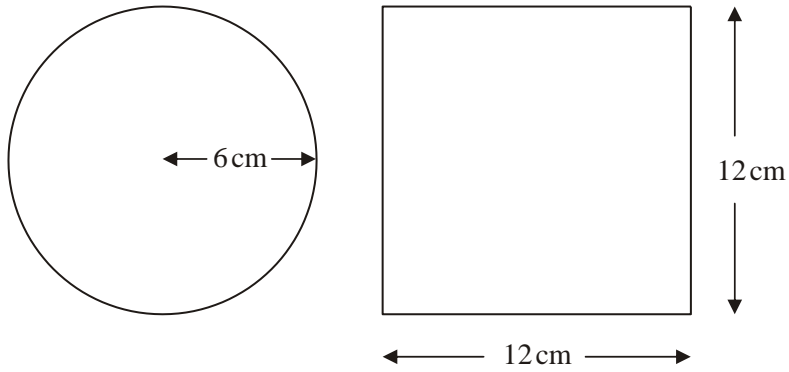

Diagram **NOT** accurately drawn

A circle has a radius of 6 cm.

A square has a side of length 12 cm.

Work out the difference between the area of the circle and the area of the square.
Give your answer correct to one decimal place.

.....

(4 marks)

13. The top of a table is a circle.
The radius of the top of the table is 50 cm.



- (a) Work out the area of the top of the table.

.....cm²

(2)

The base of the table is a circle.
The diameter of the base of the table is 40 cm.

- (b) Work out the circumference of the base of the table.

.....cm

(2)

(4 marks)

14.

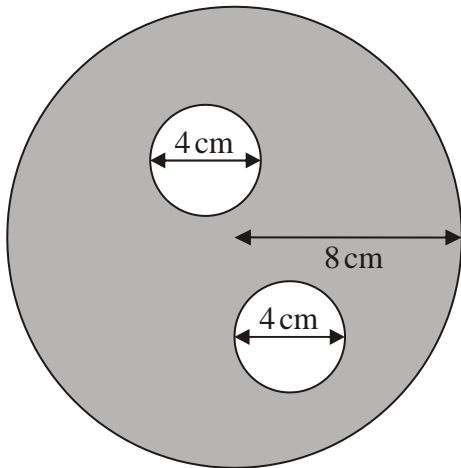

Diagram **NOT** accurately drawn

The diagram shows two small circles inside a large circle.
 The large circle has a radius of 8 cm.

Each of the two small circles has a diameter of 4 cm.

(a) Write down the radius of each of the small circles.

..... cm

(1)

(b) Work out the area of the region shown shaded in the diagram.
 Give your answer correct to one decimal place.

..... cm²

(4)

(5 marks)

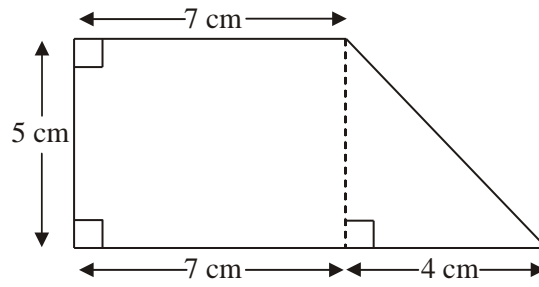

Diagram **NOT** accurately drawn

Work out the area of the shape.

..... cm²
(Total 3 marks)

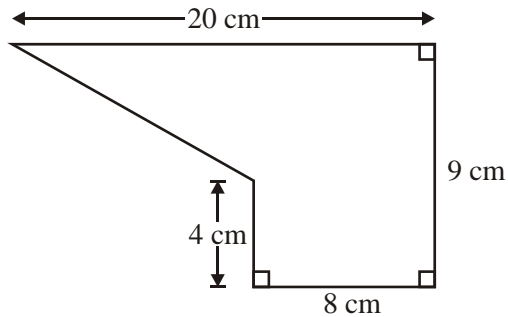

Diagram **NOT**
accurately drawn

The diagram shows a shape.
Work out the area of the shape.

..... cm²
(Total 4 marks)

Here is a trapezium.

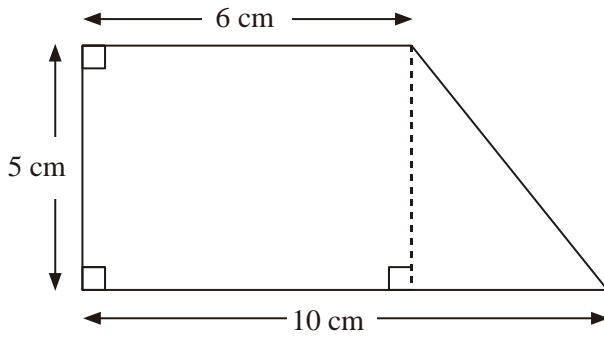

Diagram **NOT** accurately drawn

Work out the area of the trapezium.

..... cm²
(Total 2 marks)

The diagram shows a wall with a door in it.

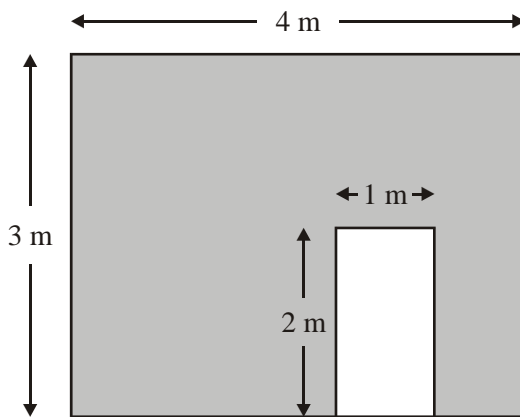
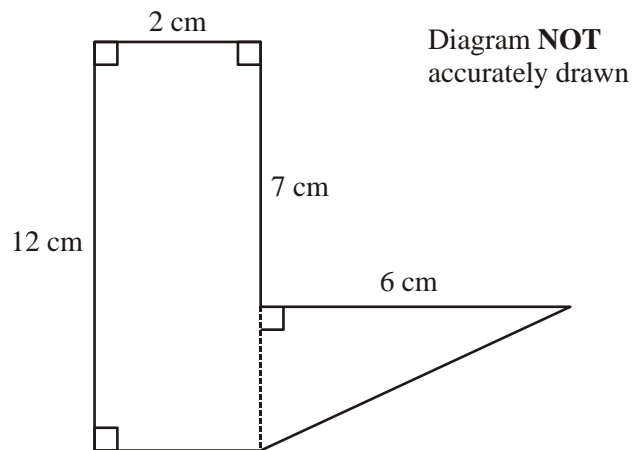

Diagram **NOT** accurately drawn

Work out the shaded area.

.....m²
(3)
(Total 3 marks)

The diagram shows a 6-sided shape made from a rectangle and a right-angled triangle.



Work out the total area of the 6-sided shape.

.....cm²
(Total 3 marks)

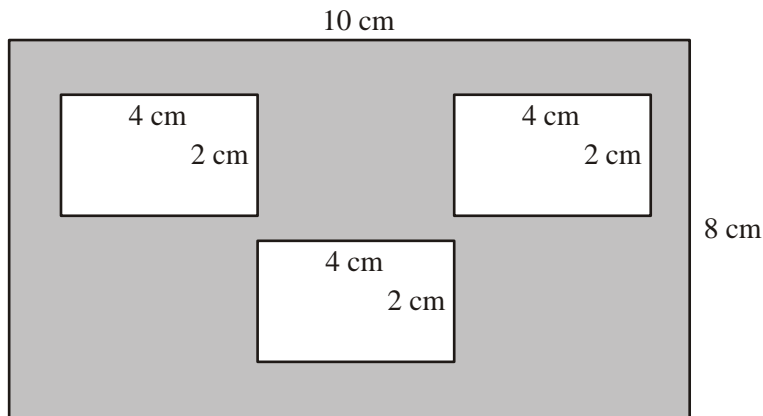

Diagram **NOT**
accurately drawn

The diagram shows 3 small rectangles inside a large rectangle.
The large rectangle is 10 cm by 8 cm.
Each of the 3 small rectangles is 4 cm by 2 cm.

Work out the area of the region shown shaded in the diagram.

.....cm²
(Total 3 marks)

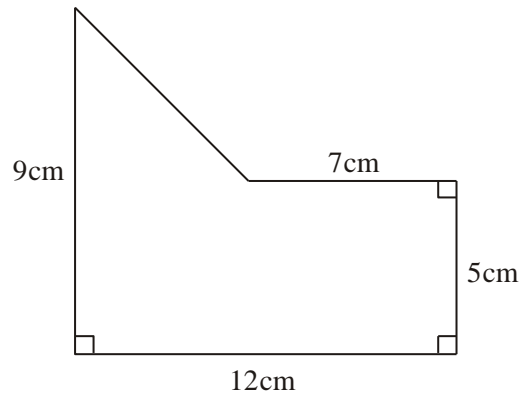

Diagram **NOT** accurately drawn

Work out the area of the shape.

..... cm²
(Total 4 marks)

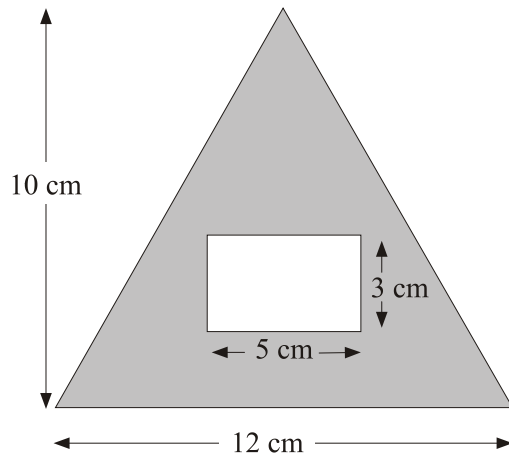

Diagram **NOT** accurately drawn

The diagram shows a rectangle inside a triangle.

The triangle has a base of 12 cm and a height of 10 cm.
The rectangle is 5 cm by 3 cm.

Work out the area of the region shown shaded in the diagram.

..... cm²
(Total 3 marks)

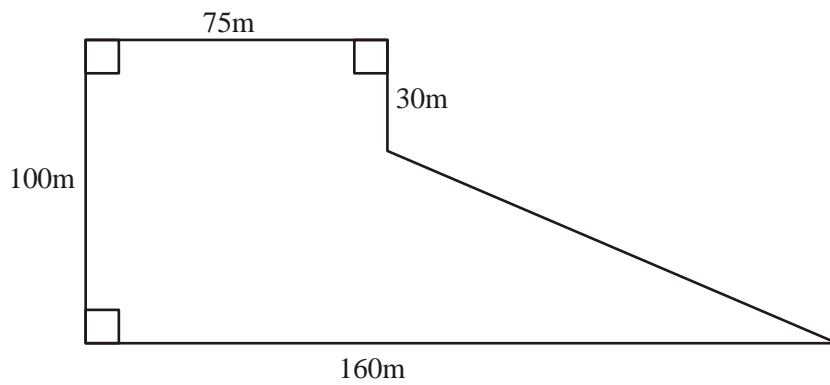

Diagram **NOT** accurately drawn

The diagram shows the plan of a field.
The farmer sells the field for £3 per square metre.

Work out the total amount of money the farmer should get.

£
(Total 5 marks)