

# Proteins and enzymes 4

Level: AQA AS 7401

Subject: Biology

Exam Board: Suitable for all boards

Topic: Proteins and enzymes 4

Type: Questionnaire

To be used by all students preparing for AQA AS Biology 7401 foundation or higher tier but also suitable for students of other boards.



**1** The diagram shows part of the metabolic pathway involved in the clotting of blood in response to an injury.

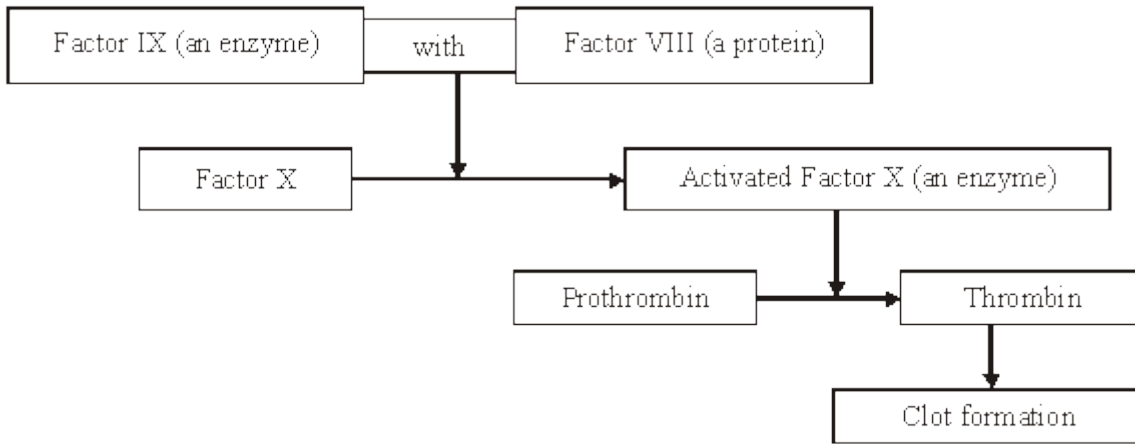

Haemophilia is a condition in which blood fails to clot. This is usually because of a mutant allele of the gene for Factor VIII.

(a) Explain how mutation could lead to faulty Factor VIII.

---

---

---

---

(2)

(b) Use information in the diagram to explain how faulty Factor VIII causes haemophilia.

---

---

---

---

(2)



- (c) A boy had haemophilia caused by faulty Factor IX. When his blood was mixed with blood from a haemophiliac with faulty Factor VIII, the mixture clotted. Suggest an explanation for clotting of the mixture.

---

---

---

---

(2)

(Total 6 marks)

2

This question should be written in continuous prose, where appropriate.

- (a) Explain how a resting potential is maintained in a neurone.

---

---

---

---

---

---

---

---

---

---

(4)



(b) In an investigation, an impulse was generated in a neurone using electrodes. During transmission along the neurone, an action potential was recorded at one point on the neurone. When the impulse reached the neuromuscular junction, it stimulated a muscle cell to contract. The force generated by the contraction was measured. The results are shown in the graph.

The distance between the point on the neurone where the action potential was measured and the neuromuscular junction was exactly 18 mm.

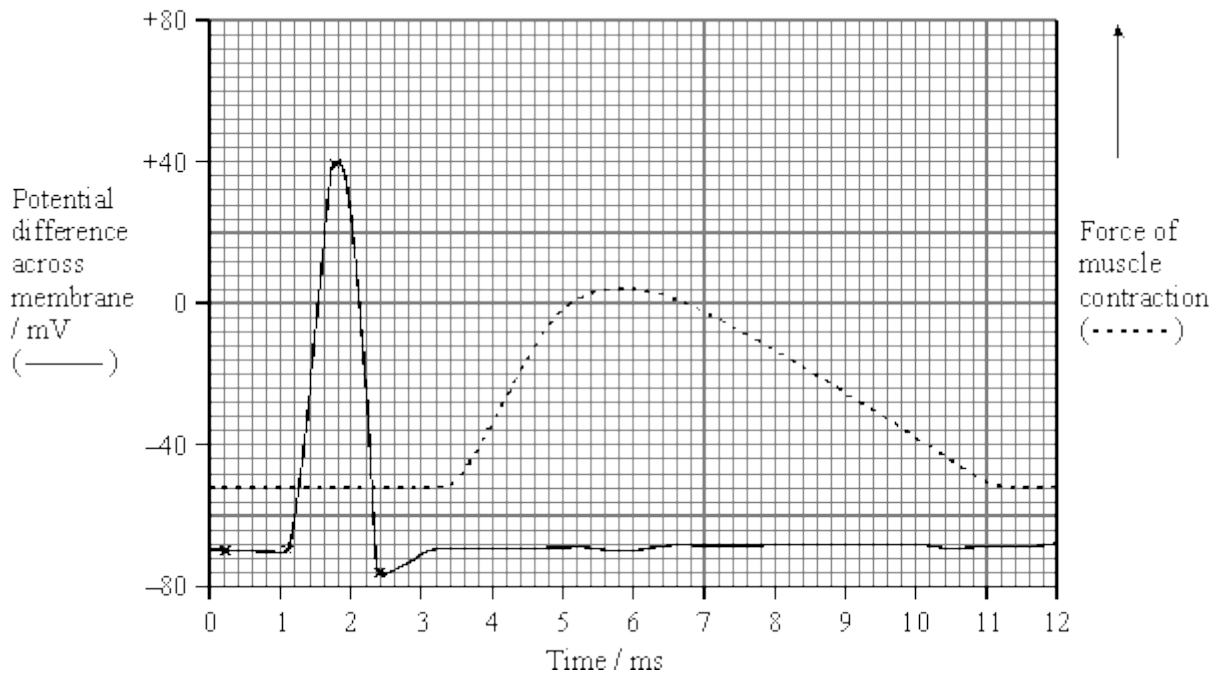

(i) Use the graph to estimate the time between the maximum depolarisation and the start of contraction by the muscle cell.

Time \_\_\_\_\_ ms

(1)

(ii) Use your answer to part (i) to calculate the speed of transmission along this neurone to the muscle cell. Give your answer in mm per second.

Show your working.

Speed \_\_\_\_\_ mm s<sup>-1</sup>

(2)



- (iii) Give **one** reason why the value calculated in part (ii) would be an underestimate of the speed of transmission of an impulse along a neurone.

---

---

(1)

Acetylcholine is the neurotransmitter at neuromuscular junctions.

- (c) Describe how the release of acetylcholine into a neuromuscular junction causes the cell membrane of a muscle fibre to depolarise.

---

---

---

---

---

---

---

(3)

- (d) Use your knowledge of the processes occurring at a neuromuscular junction to explain each of the following.

- (i) The cobra is a very poisonous snake. The molecular structure of cobra toxin is similar to the molecular structure of acetylcholine. The toxin permanently prevents muscle contraction.

---

---

---

---

(2)



- (ii) The insecticide DFP combines with the active site of the enzyme acetylcholinesterase. The muscles stay contracted until the insecticide is lost from the neuromuscular junction.

---

---

---

---

(2)

(Total 15 marks)

3

- (a) What is an enzyme?

---

---

---

---

(2)



The diagram shows stages during an enzyme-catalysed reaction.

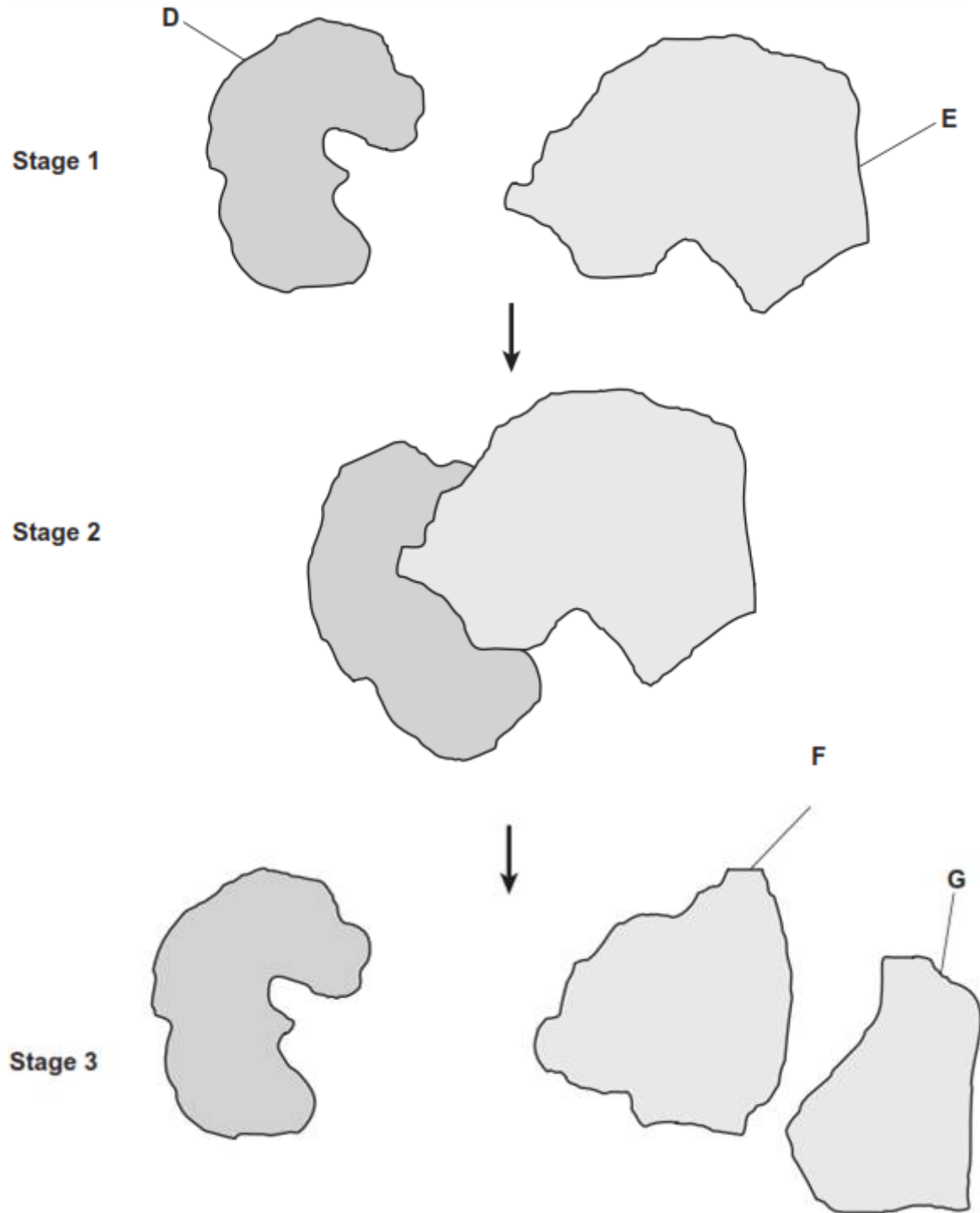



(b) Using the letters in the diagram, describe what is happening in this reaction.

---

---

---

---

---

---

---

---

*(Extra space)* \_\_\_\_\_

---

---

---

---

**(3)**  
**(Total 5 marks)**





**4** Alpha-1-antitrypsin is a protein that reduces the activity of enzymes that can damage lung tissue. Cigarette smoke contains hydrogen peroxide. Hydrogen peroxide reduces the activity of alpha-1-antitrypsin. Scientists investigated the effect of different concentrations of hydrogen peroxide on the activity of alpha-1-antitrypsin. The graph shows their results.

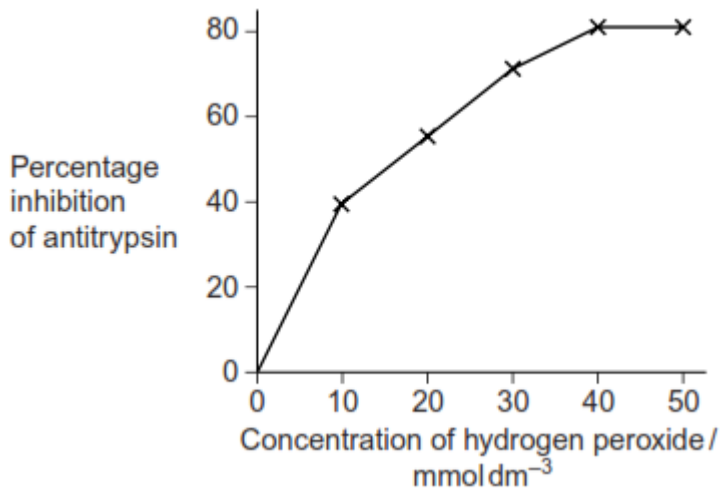

(a) (i) Hydrogen peroxide reacts with two amino acids in alpha-1-antitrypsin. Explain how this reduces activity of the protein.

---

---

---

---

(2)

(ii) Explain the results shown in the graph.

---

---

---

---

(2)

(b) Long-term smokers are often short of breath. Use this information to explain why.

---

---

---

---

(2)

(Total 6 marks)



5

Lactose is a disaccharide found in milk. In the small intestine, it is digested into glucose and galactose by the enzyme lactase. Molecules of lactase are located in the plasma membranes of cells lining the small intestine.

(a) What evidence in the paragraph suggests that galactose is a monosaccharide?

---

---

(1)

(b) (i) Name **one** other digestive enzyme that is located in the plasma membranes of cells lining the small intestine.

---

(1)

(ii) Give an advantage of lactase and other digestive enzymes being located in the plasma membranes of cells lining the small intestine, rather than being secreted into the lumen of the small intestine.

---

---

(1)

(c) The absorption of galactose from the small intestine is reduced if the absorbing cells are treated with a respiratory inhibitor, such as cyanide. Suggest an explanation for this.

---

---

---

---

(2)

(Total 5 marks)



**6** The diagram represents an enzyme molecule and three other molecules that could combine with it.

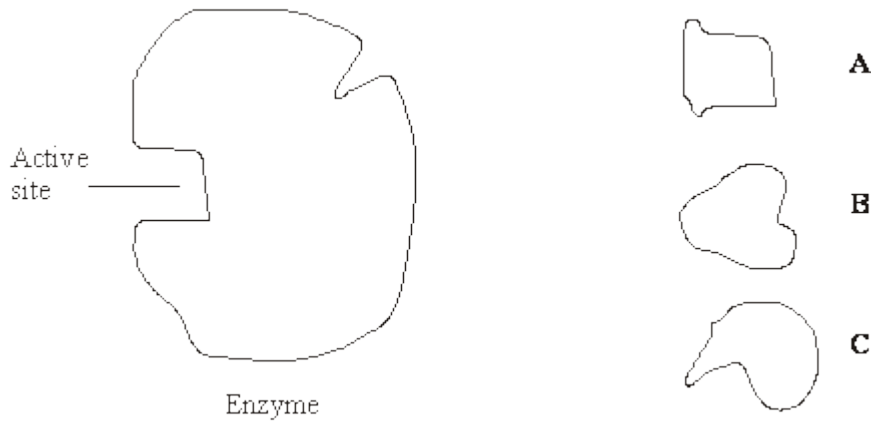

(a) Which molecule is the substrate for the enzyme? Give a reason for your answer.

---

---

---

(1)

(b) Use the diagram to explain how a **non-competitive** inhibitor would decrease the rate of the reaction catalysed by this enzyme.

---

---

---

---

---

---

(3)

(c) Lysozyme is an enzyme. A molecule of lysozyme is made up of 129 amino acid molecules joined together. In the formation of its active site, the two amino acids that are at positions 35 and 52 in the amino acid sequence need to be close together.

(i) Name the bonds that join amino acids in the primary structure.

---

(1)



- (ii) Suggest how the amino acids at positions 35 and 52 are held close together to form the active site.

---

---

---

---

(2)

(Total 7 marks)

7

The diagram shows the structure of the amino acid serine.

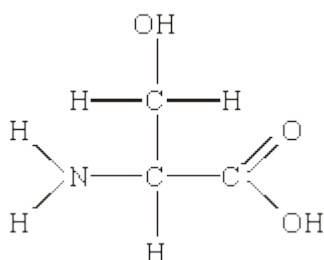

- (a) (i) Draw a box on the diagram around the R group of serine and label the box with the letter **R**.

(1)

- (ii) Draw a circle around each of the parts of the serine molecule which would be removed when **two** other amino acid molecules join directly to it.

(1)

- (b) (i) Which **two** substances are formed when two amino acid molecules join together?

1. \_\_\_\_\_

2. \_\_\_\_\_

(1)

- (ii) Name the type of bond formed between the joined pair of amino acid molecules.

\_\_\_\_\_

(1)



(c) Explain how a change in the primary structure of a globular protein may result in a different three-dimensional structure.

---

---

---

---

---

---

---

(3)  
(Total 7 marks)

**8** Pea plants are leguminous and have nodules on their roots which contain bacteria that are able to fix nitrogen. The diagram shows some of the processes involved in nitrogen fixation by these bacteria.

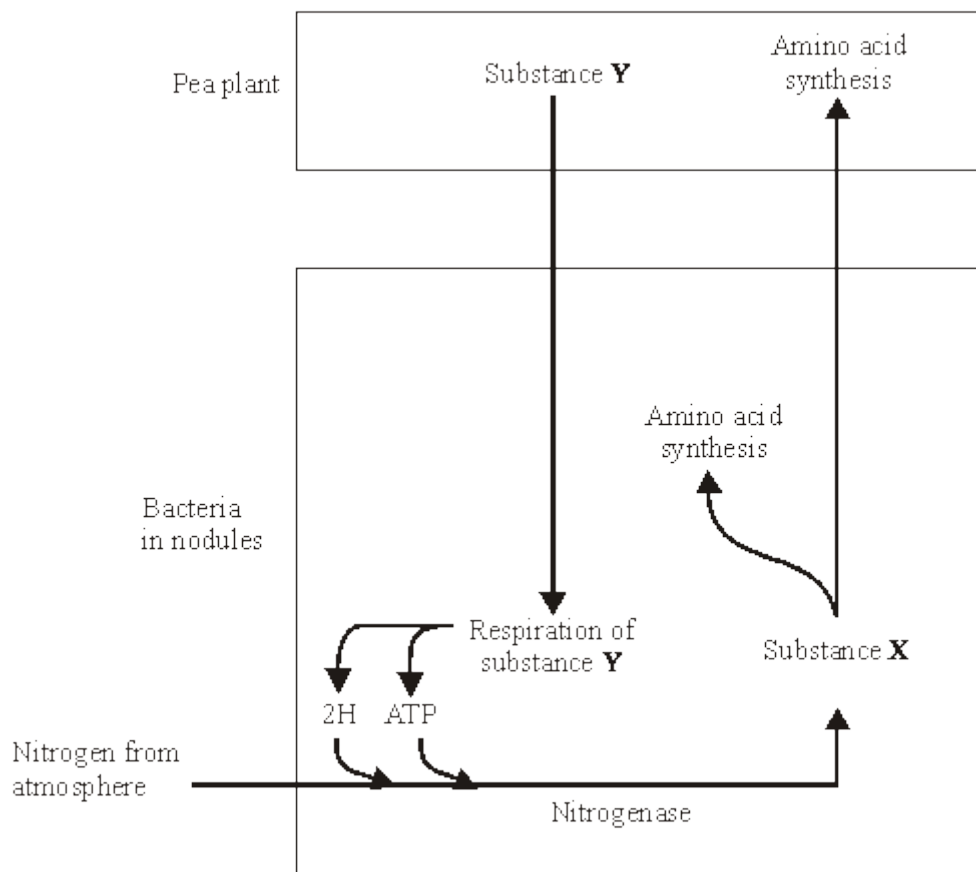



(a) Name

(i) substance X;

\_\_\_\_\_

(1)

(ii) substance Y.

\_\_\_\_\_

(1)

**S** (b) Pea plants respire aerobically, producing ATP which can be used for amino acid synthesis. Describe the role of oxygen in aerobic respiration.

\_\_\_\_\_  
\_\_\_\_\_  
\_\_\_\_\_  
\_\_\_\_\_

(2)

**S** (c) The bacteria respire anaerobically. This produces hydrogen and ATP used in nitrogen fixation. The hydrogen comes from reduced NAD. Explain how the regeneration of NAD in this way allows ATP production to continue.

\_\_\_\_\_  
\_\_\_\_\_  
\_\_\_\_\_  
\_\_\_\_\_

(2)

**S** (d) The enzyme nitrogenase is specific to the reaction shown. Explain how **one** feature of the enzyme would contribute to this specificity.

Feature

\_\_\_\_\_

Explanation

\_\_\_\_\_  
\_\_\_\_\_  
\_\_\_\_\_

(2)



- S (e) Sodium ions act as a non-competitive inhibitor of the enzyme nitrogenase. Explain how the presence of a non-competitive inhibitor can alter the rate of the reaction catalysed by nitrogenase.

---

---

---

---

---

---

(3)

(Total 11 marks)

- 9 Sucrose is a disaccharide. It is formed from two monosaccharides **P** and **Q**. The diagram shows the structure of molecules of sucrose and monosaccharide **P**.

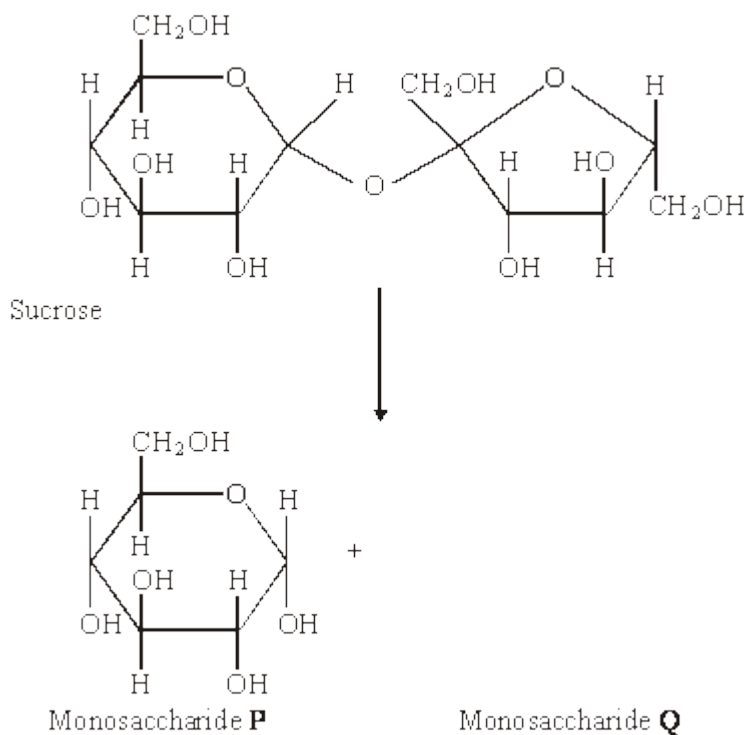

- (a) (i) Name monosaccharide **Q**.

---

(1)

- (ii) Draw the structure of a molecule of monosaccharide **Q** in the space above.

(1)



- (b) The enzyme sucrase catalyses the breakdown of sucrose into monosaccharides. What type of reaction is this breakdown?

---

(1)

- (c) The diagram shows apparatus used in breaking down sucrose. The enzyme sucrase is fixed to inert beads. Sucrose solution is then passed through the column.

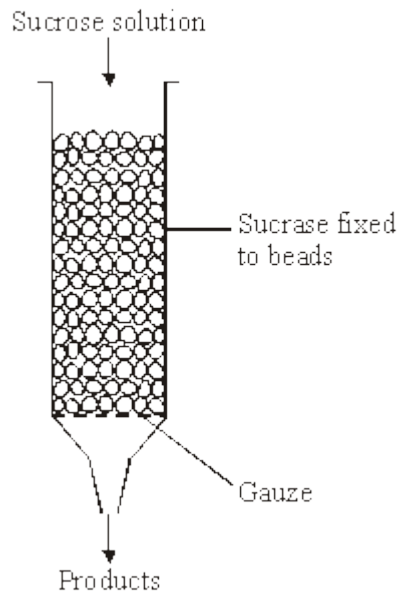

Describe a biochemical test to find out if the solution collected from the apparatus contains

- (i) the products;

---

---

---

---

(2)

- (ii) the enzyme.

---

---

---

---

(2)

(Total 7 marks)





**10** The diagrams show four types of linkage, **A** to **D**, which occur in biological molecules.

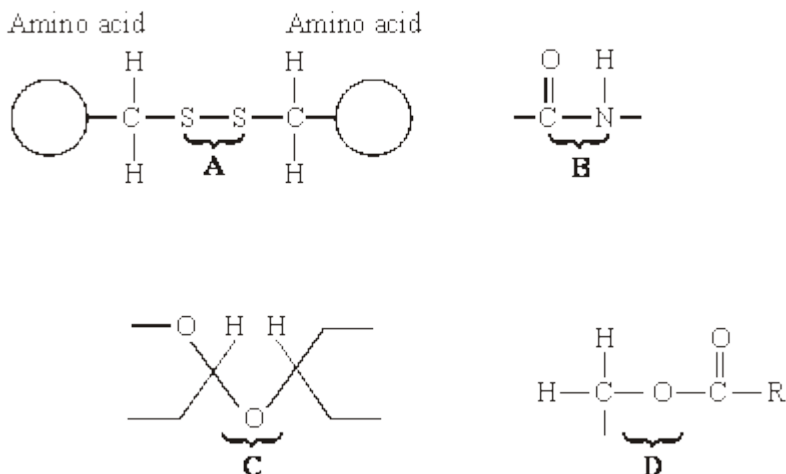

- (a) Name the chemical process involved in the formation of linkage **B**.
- \_\_\_\_\_ (1)
- (b) Give the letter of the linkage which
- (i) occurs in a triglyceride molecule;
- \_\_\_\_\_ (1)
- (ii) might be broken down by the enzyme amylase;
- \_\_\_\_\_ (1)
- (iii) may occur in the tertiary, but not the primary structure of protein.
- \_\_\_\_\_ (1)
- (c) Describe how a saturated fatty acid differs in molecular structure from an unsaturated fatty acid.
- \_\_\_\_\_
- \_\_\_\_\_
- \_\_\_\_\_
- \_\_\_\_\_ (2)

**(Total 6 marks)**



11

(a) Explain how the shape of an enzyme molecule is related to its function.

---

---

---

---

---

---

---

(3)

(b) Bacteria produce enzymes which cause food to decay. Explain how vinegar, which is acidic, can prevent the action of bacterial enzymes in some preserved foods.

---

---

---

---

---

---

---

(3)

(Total 6 marks)

12

Glaciers are masses of moving ice. When glaciers shrink, the thick covering of ice gradually disappears to leave behind bare land. Land exposed by a shrinking glacier in Alaska became covered by dense forest in 150 years.

(a) Explain how succession resulted in the formation of the forest.

---

---

---

---

---

---

---

---

---

---

(4)



(b) In areas of poor drainage the soil is waterlogged. In these areas the climax community is bog dominated by the moss, *Sphagnum*. Explain why bog is described as the climax community.

---

---

(1)

(c) Waterlogged soils lack oxygen. Suggest why trees are unable to survive in waterlogged soils.

---

---

---

---

(2)

(d) The water and soil in *Sphagnum* bogs are usually acidic. Suggest why *Sphagnum* is not fully decomposed after it dies.

---

---

---

---

---

---

---

---

(3)

(Total 10 marks)



13

(a) CFTR is a transmembrane regulator protein. Its molecules have 1480 amino acids. People with cystic fibrosis produce defective CFTR protein which is missing one amino acid from its structure.

(i) What is the minimum number of bases on DNA which would code for the normal CFTR protein? Explain your answer.

Number of bases \_\_\_\_\_

---

---

---

---

(2)

(ii) Which type of gene mutation produced the cystic fibrosis allele? Explain your answer.

---

---

---

---

(2)

(b) The diagram shows part of the process of making normal and defective CFTR in a cell. A normal CFTR protein molecule has sugar molecules attached to it which make it functional.

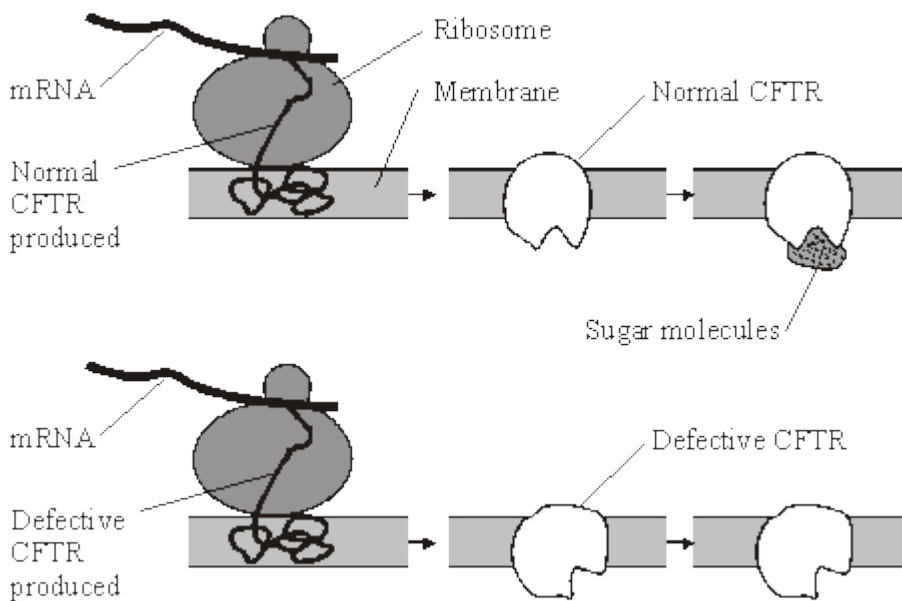



Describe how the information on mRNA is translated into CFTR at the ribosome.

---

---

---

---

---

---

---

---

---

---

(4)  
(Total 8 marks)



14 (a) The diagrams represent an enzyme, its substrate and two other molecules, **A** and **B**.

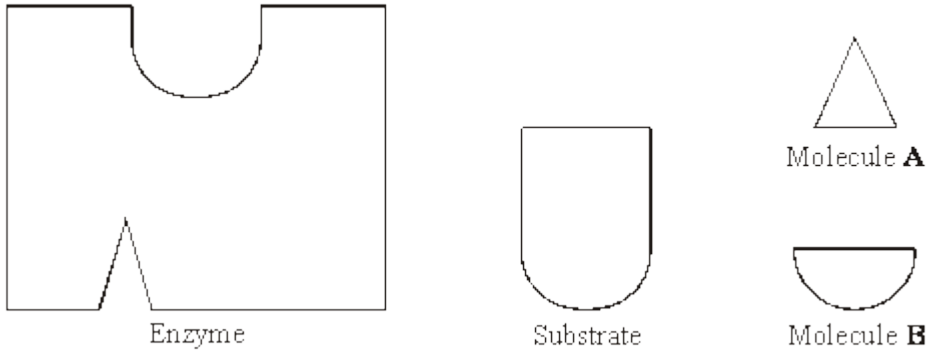

The addition of a non-competitive inhibitor will prevent the formation of an enzyme-substrate complex. Draw a labelled diagram based on relevant molecules selected from the diagram above to explain how this occurs.

(2)

(b) A decrease in temperature decreases the kinetic energy of molecules in a solution. Explain how a decrease in temperature decreases the rate of an enzyme-controlled reaction.

---

---

---

---

(2)



- (c) Urea breaks hydrogen bonds. Explain how the addition of urea would affect the rate of an enzyme-controlled reaction.

---

---

---

---

---

---

---

(3)

(Total 7 marks)

15

- (a) Describe how you would use a biochemical test to show that a solution contained protein.

---

---

---

---

(2)

The diagram shows the structure of two amino acid molecules, tyrosine and phenylalanine.

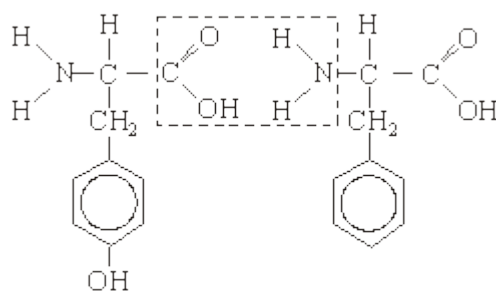

Tyrosine

Phenylalanine

- (b) Copy from the diagram the R group in the phenylalanine molecule.

(1)



- (c) (i) In the space below, draw the chemical bond formed when these two amino acids are joined by condensation. You need only draw the parts of the molecules shown in the box.

(2)

- (ii) Name this bond.

\_\_\_\_\_

(1)

- (d) Tyrosine can be made in the body by hydroxylating phenylalanine. Use the diagram to explain the meaning of *hydroxylating*.

\_\_\_\_\_  
\_\_\_\_\_

(1)

**(Total 7 marks)**

- 16** (a) Haemoglobin is a protein with a quaternary structure. What is meant by a *quaternary* structure?

\_\_\_\_\_  
\_\_\_\_\_

(1)

- (b) Explain how oxygen in a red blood cell is made available for respiration in active tissues.

\_\_\_\_\_  
\_\_\_\_\_  
\_\_\_\_\_  
\_\_\_\_\_  
\_\_\_\_\_  
\_\_\_\_\_

(3)





- (c) Haemoglobin is broken down in the liver. One product of this breakdown is amino acids. Give **one** use in the body of these amino acids.

---

---

(1)  
(Total 5 marks)

17

Homeostatic mechanisms maintain a constant environment in the body.

- (a) The graph shows changes in plasma glucose concentration that occurred in a person who went without food for some time.

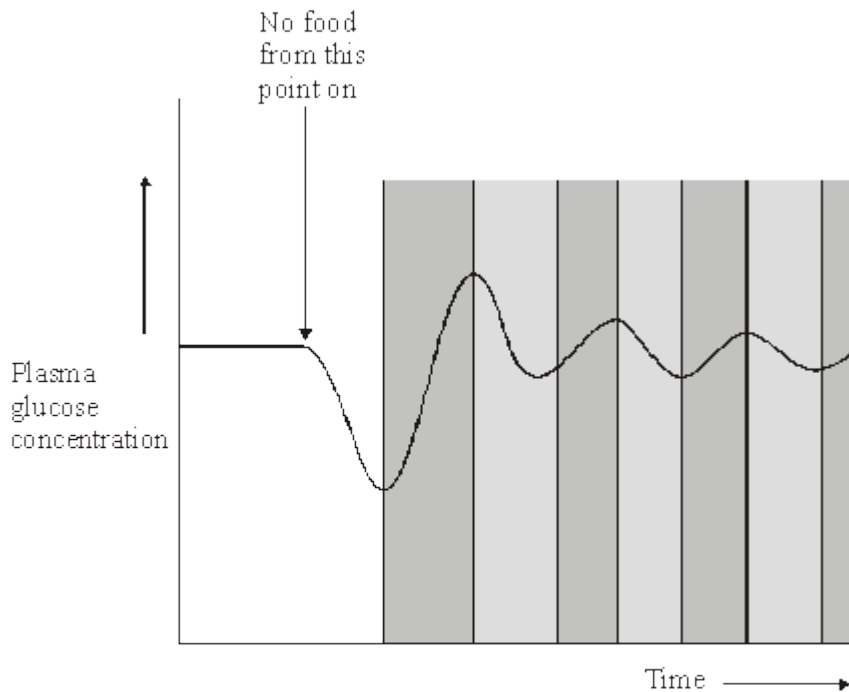

- Key
- Change in this period due to glucagon
  - Change in this period due to insulin



Use evidence from the graph to explain the role of negative feedback in the control of plasma glucose concentration.

---

---

---

---

---

---

---

---

---

---

---

---

---

---

---

---

---

---

---

---

---

---

---

---

(5)

(b) How does maintaining a constant body temperature allow metabolic reactions in cells to proceed with maximum efficiency?

---

---

---

---

---

---

---

---

---

---

---

---

---

---

---

---

---

---

---

---

---

---

---

---

(5)

(Total 10 marks)