

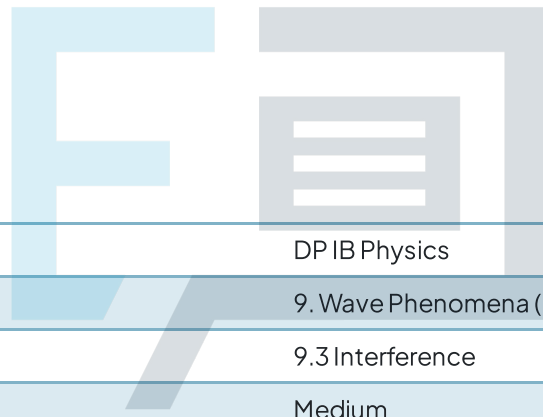

9.3 Interference

Question Paper



Course	DP IB Physics
Section	9. Wave Phenomena (HL only)
Topic	9.3 Interference
Difficulty	Medium

Exam Papers Practice

To be used by all students preparing for DP IB Physics HL
Students of other boards may also find this useful

Question 1

Waves emitted from sources V and W are initially in phase and have equal wavelengths. Point A is not equidistant between V and W. The waves interfere destructively at point A, where the path difference is 0.30 m.

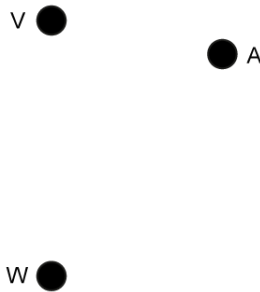

What is the maximum possible value of the wavelength of the waves?

- A. 0.60 m
- B. 0.30 m
- C. 0.20 m
- D. 0.12 m



[1 mark]

Exam Papers Practice

Question 2

The diagram below shows an arrangement for a two-slit interference experiment. Coherent light of frequency f is incident on two narrow parallel slits S_1 and S_2 . An interference pattern is observed on a screen a distance away. The central bright fringe is at O and the next bright fringe is at P . The speed of light is c .

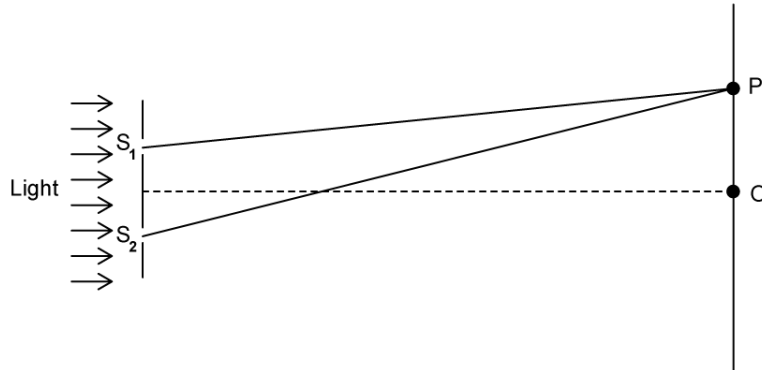

The distance $S_2P - S_1P$ is equal to

- A. $\frac{f}{c}$
- B. $\frac{c}{2f}$
- C. $\frac{c}{f}$
- D. $\frac{f}{2c}$

Question 3

The interference of light waves is observed using a double-slit arrangement as shown below.

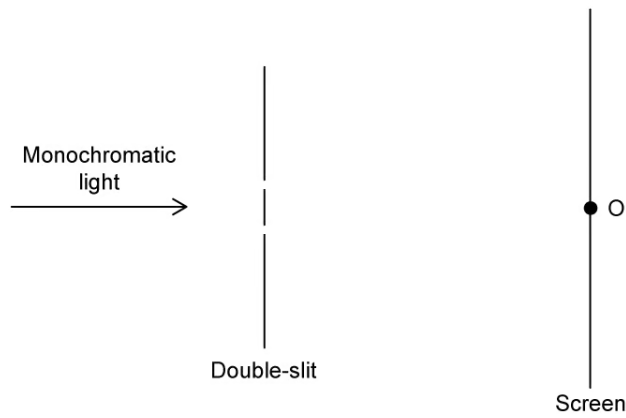

Which of the following best shows the intensity distribution of light at point O on the screen?

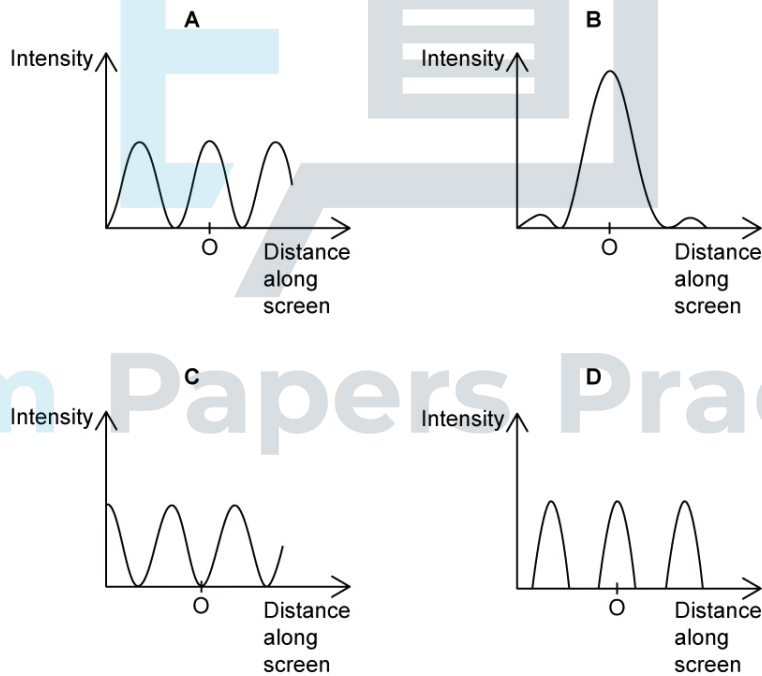

[1 mark]

Question 4

In an experiment, light incident on a diffraction grating has a first maximum of the second order in the same location as the first minimum of a single slit diffraction pattern. The light source and the distance from the slits to the screen are kept the same.

What is the relationship between the slit separation d and the slit width b ?

A. $d = 2b$

B. $d = \frac{b}{4}$

C. $d = 4b$

D. $d = \frac{b}{2}$

[1 mark]



Exam Papers Practice

Question 5

The graph shows the intensity pattern from the interference of monochromatic light passing through N slits.

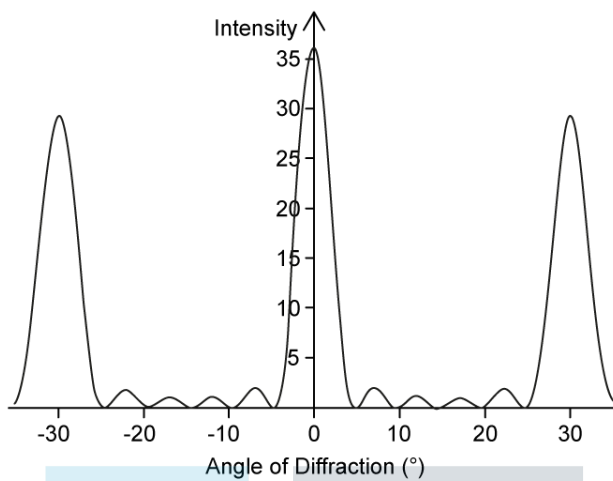

Which row gives the correct value of N and the correct relationship between the slit separation d and the wavelength λ ?

	N	Relationship
A.	6	$d = \frac{\lambda}{2}$
B.	6	$d = 2\lambda$
C.	4	$d = 2\lambda$
D.	4	$d = \frac{\lambda}{2}$

Exam Papers Practice [1 mark]

Question 6

Monochromatic light of wavelength, 6λ is incident on a thin film of transparent plastic with a refractive index $1.5n$. The film is surrounded by air. The intensity of the light observed reflected off the film is a minimum. What is a possible thickness of the plastic?

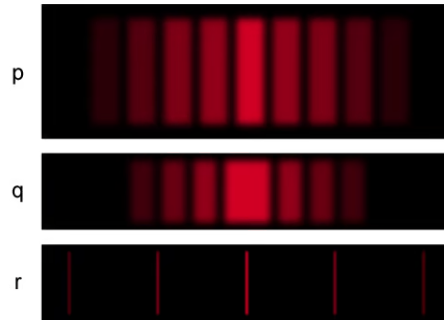

- A. $\frac{\lambda}{n}$
- B. $\frac{\lambda}{3n}$
- C. $\frac{\lambda}{2n}$
- D. $\frac{12\lambda}{n}$



[1 mark]

Exam Papers Practice

Question 7

Red light is incident on a diffraction grating, a double-slit and a single-slit. The patterns produced on a screen some distance away are shown below.

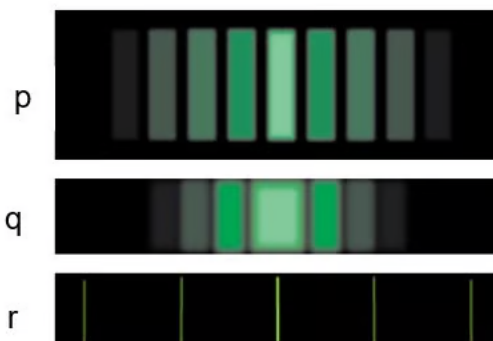

Which row in the table correctly identifies patterns p, q and r?

	p	q	r
A.	Diffraction Grating	Double Slit	Single Slit
B.	Double Slit	Single Slit	Diffraction Grating
C.	Single Slit	Double Slit	Diffraction Grating
D.	Diffraction Grating	Single Slit	Double Slit

[1 mark]

Exam Papers Practice

Question 8

Which of the following statements about thin film interference are correct?

- I. A phase change occurs at a boundary between a more dense and a less dense material
- II. A phase change always involves some reflection and transmission
- III. The wavelength of a wave transmitted between materials of different densities stays the same
- IV. Light in a thin film travels a distance of two times the thickness of the film when it enters and leaves the film at the same surface to undergo destructive interference

- A. I, II and III
- B. I and II only
- C. II only
- D. IV only

[1 mark]

Question 9

The graph shows the variation with diffraction angle of the intensity of light when monochromatic light is incident on a diffraction grating.

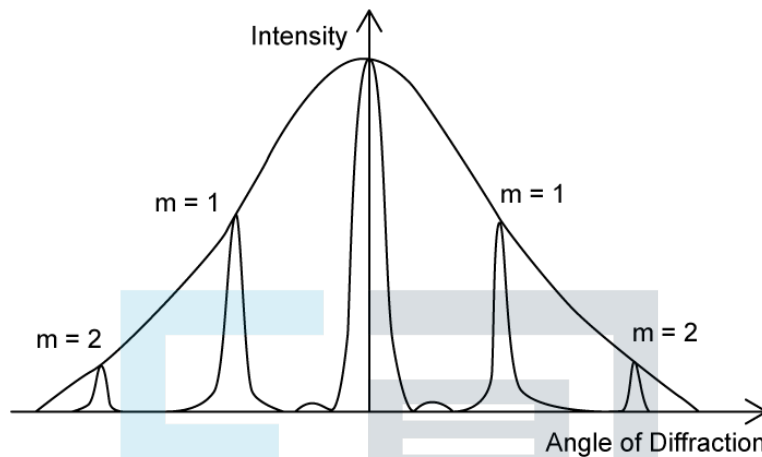

The number of slits is reduced to less than 20. The width and the separation of the slits remain the same.

Three possible changes to the pattern are:

- I. The intensity of the primary maxima increases
- II. The width of the primary maxima increases
- III. Secondary maxima are seen between the primary maxima

Which of the possible changes are correct?

- A. I and II only
- B. I and III only
- C. II and III only
- D. I, II and III only

[1 mark]

Question 10

A beam of monochromatic light is incident normally on a double slit. The slit spacing is d . The angles between the different orders are shown on the diagram.

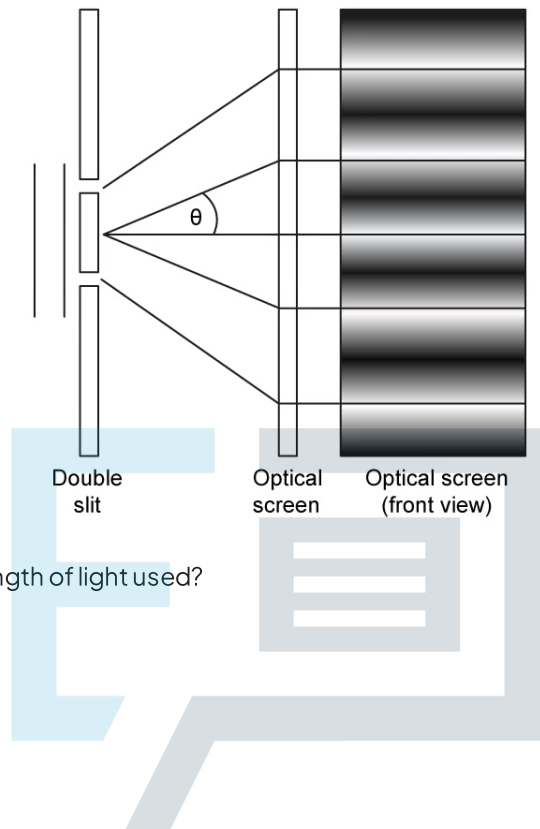

What is the expression for the wavelength of light used?

- A. $\lambda = sD$
- B. $\lambda = s\theta$
- C. $\lambda = \theta D$
- D. $\lambda = \theta d$

[1 mark]

Exam Papers Practice