

Please write clearly in block capitals.

Centre number

--	--	--	--	--

Candidate number

--	--	--	--

Surname

Forename(s)

Candidate signature

GCSE CHEMISTRY

H

Higher Tier Paper 1

Thursday 16 May 2019

Morning

Time allowed: 1 hour 45 minutes

Materials

For this paper you must have:

- a ruler
- a scientific calculator
- the periodic table (enclosed).

Instructions

- Use black ink or black ball-point pen.
- Fill in the boxes at the top of this page.
- Answer **all** questions in the spaces provided. Do not write outside the box around each page or on blank pages.
- Do all rough work in this book. Cross through any work you do not want to be marked.
- In all calculations, show clearly how you work out your answer.

Information

- The maximum mark for this paper is 100.
- The marks for questions are shown in brackets.
- You are expected to use a calculator where appropriate.
- You are reminded of the need for good English and clear presentation in your answers.

For Examiner's Use

Question	Mark
1	
2	
3	
4	
5	
6	
7	
8	
9	
TOTAL	



Answer **all** questions in the spaces provided.

0 1

This question is about the periodic table.

In the 19th century, some scientists tried to classify the elements by arranging them in order of their atomic weights.

Figure 1 shows the periodic table Mendeleev produced in 1869.

His periodic table was more widely accepted than previous versions.

Figure 1

	Group 1	Group 2	Group 3	Group 4	Group 5	Group 6	Group 7
Period 1	H						
Period 2	Li	Be	B	C	N	O	F
Period 3	Na	Mg	Al	Si	P	S	Cl
Period 4	K Cu	Ca Zn	* *	Ti *	V As	Cr Se	Mn Br
Period 5	Rb Ag	Sr Cd	Y In	Zr Sn	Nb Sb	Mo Te	* I

0 1 . 1

The atomic weight of tellurium (Te) is 128 and that of iodine (I) is 127

Why did Mendeleev reverse the order of these two elements?

[1 mark]



0 1 . 2 Mendeleev left spaces marked with an asterisk *

He left these spaces because he thought missing elements belonged there.

Why did Mendeleev's periodic table become more widely accepted than previous versions?

[3 marks]

0 1 . 3 Mendeleev arranged the elements in order of their atomic weight.

What is the modern name for atomic weight?

[1 mark]

Tick (✓) **one** box.

Atomic number

Mass number

Relative atomic mass

Relative formula mass

0 1 . 4 Complete the sentence.

[1 mark]

In the modern periodic table, the elements are arranged in order of

_____.

Turn over ►



Chlorine, iodine and astatine are in Group 7 of the modern periodic table.

0 1 . 5 Astatine (At) is below iodine in Group 7.

Predict:

- the formula of an astatine molecule
- the state of astatine at room temperature.

[2 marks]

Formula of astatine molecule _____

State at room temperature _____

0 1 . 6 Sodium is in Group 1 of the modern periodic table.

Describe what you would see when sodium reacts with chlorine.

[2 marks]

10



0 2 This question is about acids and alkalis.

0 2 . 1 Which ion do all acids produce in aqueous solution?

[1 mark]

Tick (✓) **one** box.

H⁺

H⁻

O²⁻

OH⁻

0 2 . 2 Calcium hydroxide solution reacts with an acid to form calcium chloride.

Complete the word equation for the reaction.

[2 marks]

calcium hydroxide + _____ acid → calcium chloride + _____

Question 2 continues on the next page

Turn over ►



A student investigates the volume of sodium hydroxide solution that reacts with 25.0 cm^3 of dilute sulfuric acid.

Figure 2 shows the apparatus the student uses.

Figure 2

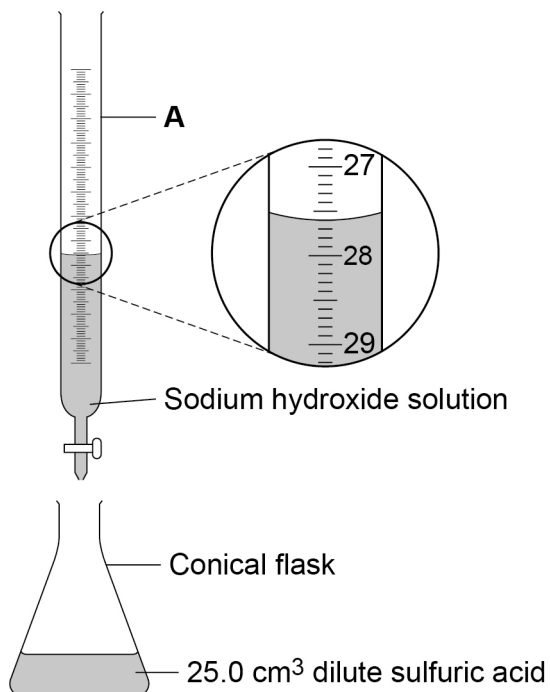

Use **Figure 2** to answer Questions **02.3** and **02.4**

0 2 . 3

Name apparatus **A**.

[1 mark]

0 2 . 4

What is the reading on apparatus **A**?

[1 mark]

_____ cm^3



0 2 . 5

The higher the concentration of a sample of dilute sulfuric acid, the greater the volume of sodium hydroxide needed to neutralise the acid.

The student tested two samples of dilute sulfuric acid, **P** and **Q**.

Describe how the student could use titrations to find which sample, **P** or **Q**, is more concentrated.

[6 marks]

Turn over ►

0 3

This question is about materials and their properties.

0 3 . 1

Figure 3 shows a carbon nanotube.

Figure 3

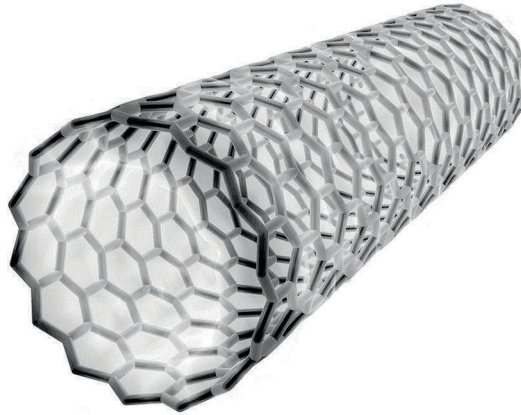

The structure and bonding in a carbon nanotube are similar to graphene.

Carbon nanotubes are used in electronics because they conduct electricity.

Explain why carbon nanotubes conduct electricity.

[2 marks]

0 3 . 2

Figure 4 shows a badminton racket.

Figure 4

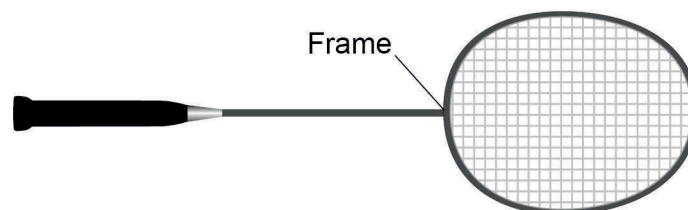

Table 1 shows some properties of materials.

The materials could be used to make badminton racket frames.

Table 1

Material	Density in g/cm^3	Relative strength	Relative stiffness
Aluminium	2.7	0.3	69
Carbon nanotube	1.5	60	1000
Wood	0.71	0.1	10

Evaluate the use of the materials to make badminton racket frames.

Use **Table 1**.

[4 marks]

Turn over ►



Zinc oxide can be produced as nanoparticles and as fine particles.

0 3 . 3 A nanoparticle of zinc oxide is a cube of side 82 nm

Figure 5 represents a nanoparticle of zinc oxide.

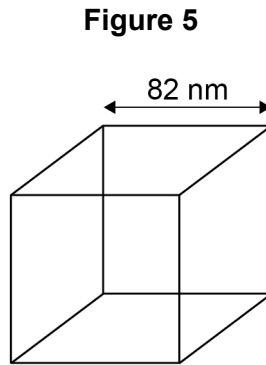

Calculate the surface area of a nanoparticle of zinc oxide.

Give your answer in standard form.

[3 marks]

Surface area = _____ nm²

0 3 . 4 Some suncreams contain zinc oxide as nanoparticles or as fine particles.

Suggest **one** reason why it costs less to use nanoparticles rather than fine particles in suncreams.

[1 mark]



0 4

This question is about atomic structure.

0 4 . 1

Atoms contain subatomic particles.

Table 2 shows properties of two subatomic particles.Complete **Table 2**.**[2 marks]****Table 2**

Name of particle	Relative mass	Relative charge
neutron		
		+1

An element **X** has two isotopes.

The isotopes have different mass numbers.

0 4 . 2

Define mass number.

[1 mark]

0 4 . 3

Why is the mass number different in the two isotopes?

[1 mark]

Question 4 continues on the next page**Turn over ►**

0	4	.	4
---	---	---	---

The model of the atom changed as new evidence was discovered.

The plum pudding model suggested that the atom was a ball of positive charge with electrons embedded in it.

Evidence from the alpha particle scattering experiment led to a change in the model of the atom from the plum pudding model.

Explain how.

[4 marks]

8



0 5

This question is about ammonia, NH_3

0 5 . 1

Complete the dot and cross diagram for the ammonia molecule shown in **Figure 6**.

Show only the electrons in the outer shell of each atom.

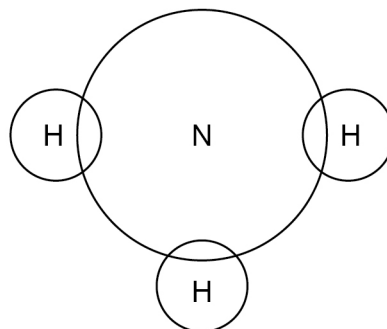
[2 marks]**Figure 6**

0 5 . 2

Give **one** limitation of using a dot and cross diagram to represent an ammonia molecule.**[1 mark]**

0 5 . 3

Explain why ammonia has a low boiling point.

You should refer to structure and bonding in your answer.

[3 marks]

Turn over ►

Ammonia reacts with oxygen in the presence of a metal oxide catalyst to produce nitrogen and water.

0 5 . 4 Which metal oxide is most likely to be a catalyst for this reaction?

[1 mark]

Tick (✓) **one** box.

CaO

Cr₂O₃

MgO

Na₂O

Figure 7 shows the displayed formula equation for the reaction.

Figure 7

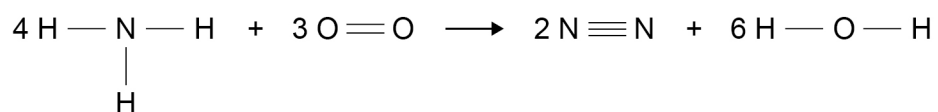

Table 3 shows some bond energies.

Table 3

Bond	N — H	O = O	N ≡ N	O — H
Bond energy in kJ/mol	391	498	945	464



0 5 . 5 Calculate the overall energy change for the reaction.

Use **Figure 7** and **Table 3**.

[3 marks]

Overall energy change = _____ kJ

0 5 . 6 Explain why the reaction between ammonia and oxygen is exothermic.

Use values from your calculation in Question **05.5**

[2 marks]

Question 5 continues on the next page

Turn over ►



0 5 . 7

Figure 8 shows the reaction profile for the reaction between ammonia and oxygen.

Complete **Figure 8** by labelling the:

- activation energy
- overall energy change.

[2 marks]

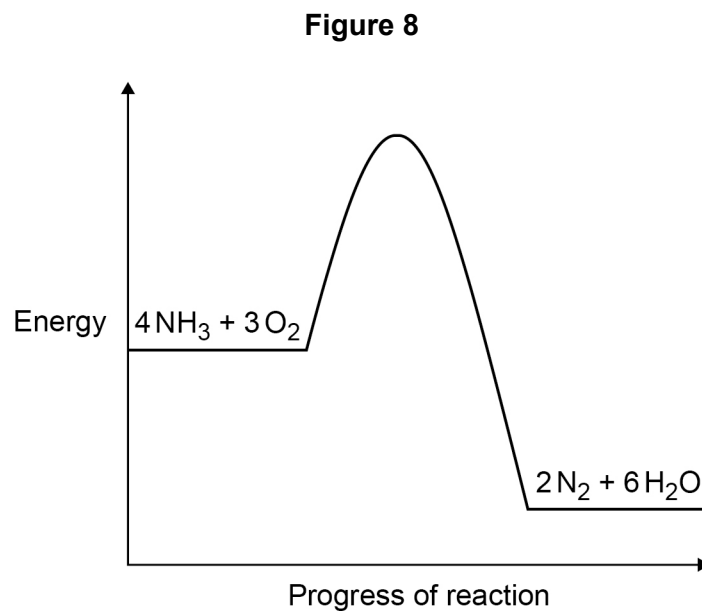

0 6

This question is about chemical cells.

A student investigated the voltage produced by different chemical cells.

Figure 9 shows the apparatus.

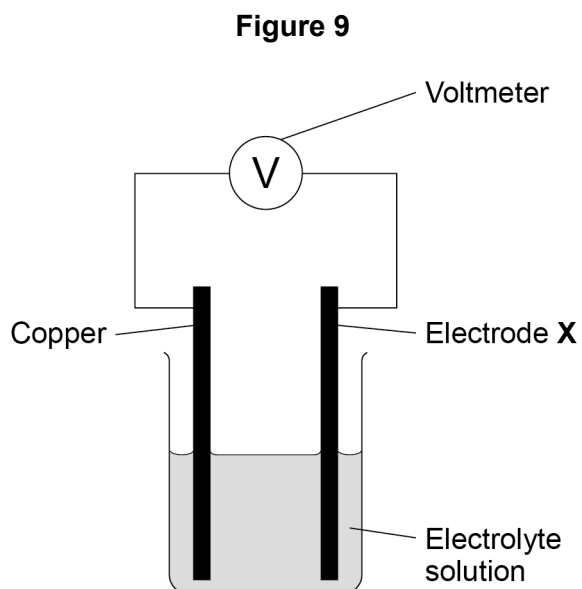

This is the method used.

1. Use cobalt as electrode **X**.
2. Record the cell voltage.
3. Repeat steps 1 and 2 using different metals as electrode **X**.

0 6

. 1

Suggest **two** control variables used in this investigation.

[2 marks]

1 _____

2 _____

Turn over ►



Table 4 shows the student's results.

Table 4

Electrode X	Voltage of cell in volts
cobalt	+0.62
copper	0.00
magnesium	+2.71
nickel	+0.59
silver	-0.46
tin	+0.48

0 6 . 2 Write the six metals used for electrode **X** in order of reactivity.

Use **Table 4**.

Justify your order of reactivity.

[4 marks]

Most reactive _____

Least reactive _____

Justification _____



0 6 . 3

Which of the following pairs of metals would produce the greatest voltage when used as the electrodes in the cell?

Use **Table 4**.

[1 mark]

Tick (✓) **one** box.

Magnesium and cobalt

Magnesium and tin

Nickel and cobalt

Nickel and tin

0 6 . 4

Hydrogen fuel cells can be used to power different forms of transport.

Some diesel trains are being converted to run on hydrogen fuel cells.

A newspaper article referred to the converted trains as the new 'steam trains'.

Suggest why.

[2 marks]

9

Turn over ►



07

This question is about electrolysis.

Aluminium is produced by electrolysis of a molten mixture of aluminium oxide and cryolite.

07.1

Explain why a mixture is used as the electrolyte instead of using only aluminium oxide.

[2 marks]

07.2

What happens at the negative electrode during the production of aluminium?

[1 mark]

Tick (✓) **one** box.

Aluminium atoms gain electrons.

Aluminium atoms lose electrons.

Aluminium ions gain electrons.

Aluminium ions lose electrons.

07.3

Oxygen is produced at the positive electrode.

Complete the balanced half-equation for the process at the positive electrode.

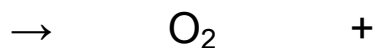
[2 marks]

07.4

Explain why the positive electrode must be continually replaced.

[3 marks]

07.5

The overall equation for the electrolysis of aluminium oxide is:

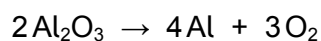

Calculate the mass of oxygen produced when 2000 kg of aluminium oxide is completely electrolysed.

Relative atomic masses (A_r): O = 16 Al = 27

[4 marks]

Mass of oxygen = _____ kg

Turn over ►

Sodium metal and chlorine gas are produced by the electrolysis of molten sodium chloride.

0 7 . 6 Explain why sodium chloride solution **cannot** be used as the electrolyte to produce sodium metal.

[2 marks]

0 7 . 7 Calculate the volume of 150 kg of chlorine gas at room temperature and pressure.

The volume of one mole of any gas at room temperature and pressure is 24.0 dm^3

Relative formula mass (M_r): $\text{Cl}_2 = 71$

[2 marks]

Volume = _____ dm^3

16



Turn over for the next question

*Do not write
outside the
box*

**DO NOT WRITE ON THIS PAGE
ANSWER IN THE SPACES PROVIDED**

Turn over ►



0 8

Copper forms two oxides, Cu_2O and CuO

A teacher investigated an oxide of copper.

Figure 10 shows the apparatus.

Figure 10

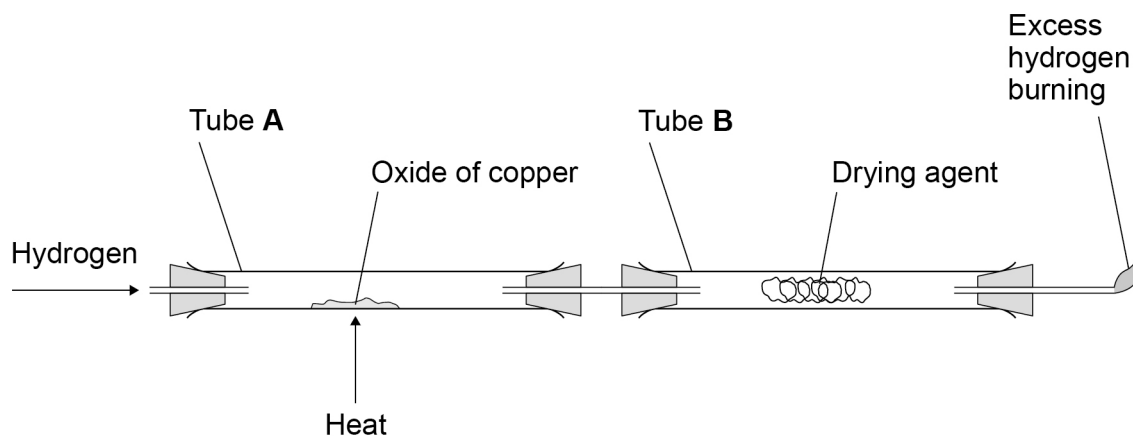

This is the method used.

1. Weigh empty tube **A**.
2. Add some of the oxide of copper to tube **A**.
3. Weigh tube **A** and the oxide of copper.
4. Weigh tube **B** and drying agent.
5. Pass hydrogen through the apparatus and light the flame at the end.
6. Heat tube **A** for 2 minutes.
7. Reweigh tube **A** and contents.
8. Repeat steps 5 to 7 until the mass no longer changes.
9. Reweigh tube **B** and contents.
10. Repeat steps 1 to 9 with different masses of the oxide of copper.



0 8 . 1 Suggest **one** reason why step 8 is needed.

[1 mark]

0 8 . 2 Explain why the excess hydrogen must be burned off.

[2 marks]

Question 8 continues on the next page

Turn over ►



Figure 10 is repeated here.

Figure 10

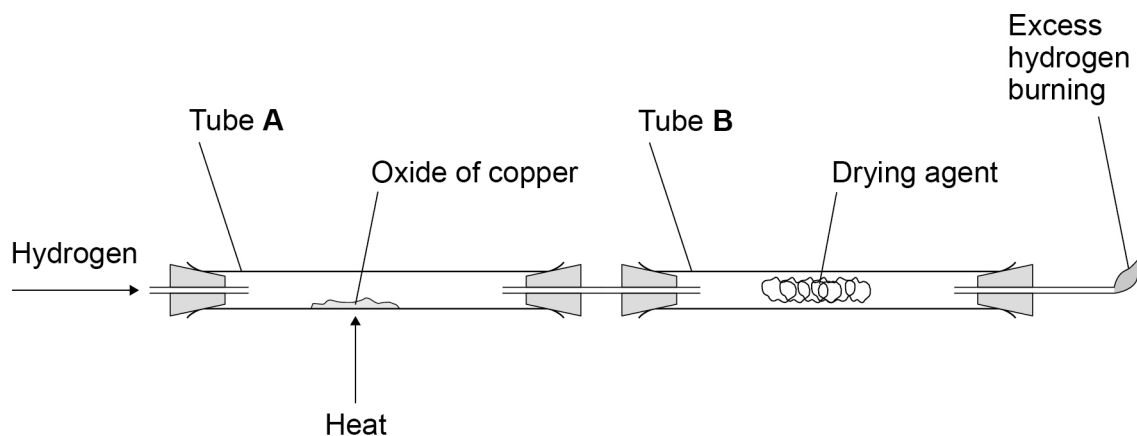

Table 5 shows the teacher's results.

Table 5

	Mass in g
Tube A empty	105.72
Tube A and oxide of copper before heating	115.47
Tube A and contents after 2 minutes	114.62
Tube A and contents after 4 minutes	114.38
Tube A and contents after 6 minutes	114.38
Tube B and contents at start	120.93
Tube B and contents at end	123.38

When an oxide of copper is heated in a stream of hydrogen, the word equation for the reaction is:



0 8 . 3 Determine the mass of copper and the mass of water produced in this experiment.

Use **Table 5**.

[2 marks]

Mass of copper = _____ g

Mass of water = _____ g

0 8 . 4 The teacher repeated the experiment with a different sample of the oxide of copper.

The teacher found that the oxide of copper produced 2.54 g of copper and 0.72 g of water.

Two possible equations for the reaction are:

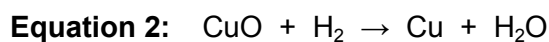
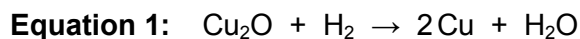

Determine which is the correct equation for the reaction in the teacher's experiment.

Relative atomic masses (A_r): H = 1 O = 16 Cu = 63.5

[3 marks]

8

Turn over for the next question

Turn over ►



There are no questions printed on this page

*Do not write
outside the
box*

**DO NOT WRITE ON THIS PAGE
ANSWER IN THE SPACES PROVIDED**



0 9

A student investigated the temperature change in the reaction between dilute sulfuric acid and potassium hydroxide solution.

This is the method used.

1. Measure 25.0 cm³ potassium hydroxide solution into a polystyrene cup.
2. Record the temperature of the solution.
3. Add 2.0 cm³ dilute sulfuric acid.
4. Stir the solution.
5. Record the temperature of the solution.
6. Repeat steps 3 to 5 until a total of 20.0 cm³ dilute sulfuric acid has been added.

0 9 . 1

Suggest why the student used a polystyrene cup rather than a glass beaker for the reaction.

[2 marks]

Question 9 continues on the next page

Turn over ►

Table 6 shows some of the student's results.

Table 6

Volume of dilute sulfuric acid added in cm ³	Temperature in °C
0.0	18.9
2.0	21.7
4.0	23.6
6.0	25.0
8.0	26.1
10.0	27.1

Figure 11 shows some of the data from the investigation.

Figure 11

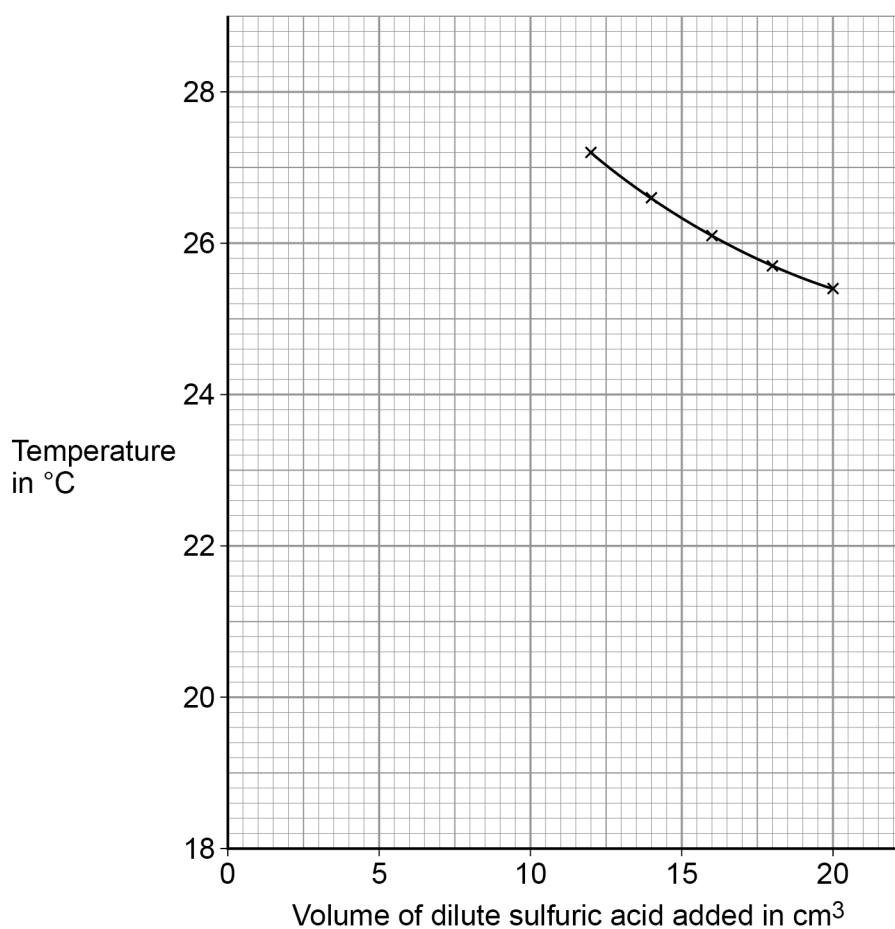

0 9 . 2 Complete **Figure 11**:

- plot the data from **Table 6**
- draw a line of best fit through these points
- extend the lines of best fit until they cross.

[4 marks]

0 9 . 3 Determine the volume of dilute sulfuric acid needed to react completely with 25.0 cm³ of the potassium hydroxide solution.

Use **Figure 11**.

[1 mark]

Volume of dilute sulfuric acid to react completely = _____ cm³

0 9 . 4 Determine the overall temperature change when the reaction is complete.

Use **Figure 11**.

[1 mark]

Overall temperature change = _____ °C

Question 9 continues on the next page

Turn over ►



0 9 . 5

The student repeated the investigation.

The student used solutions that had different concentrations from the first investigation.

The student found that 15.5 cm³ of 0.500 mol/dm³ dilute sulfuric acid completely reacted with 25.0 cm³ of potassium hydroxide solution.

The equation for the reaction is:

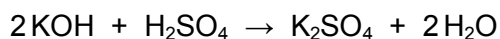

Calculate the concentration of the potassium hydroxide solution in mol/dm³ and in g/dm³

Relative atomic masses (A_r): H = 1 O = 16 K = 39

[6 marks]

Concentration in mol/dm³ = _____ mol/dm³

Concentration in g/dm³ = _____ g/dm³

END OF QUESTIONS

14

Copyright information

For confidentiality purposes acknowledgements of third-party copyright material are published in a separate booklet which is available for free download from www.aqa.org.uk after the live examination series.

Copyright © 2019 AQA and its licensors. All rights reserved.



3 2



1 9 6 G 8 4 6 2 / 1 H

IB/G/Jun19/8462/1H