

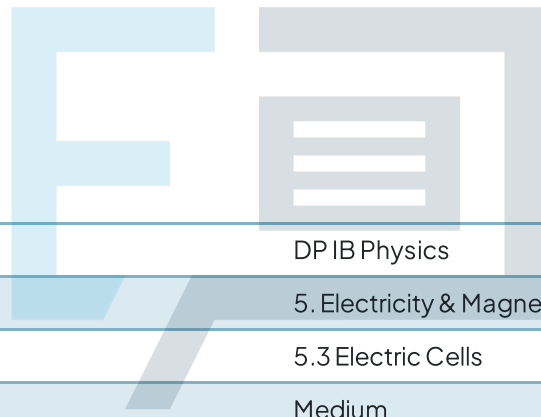

5.3 Electric Cells

Question Paper



Course	DP IB Physics
Section	5. Electricity & Magnetism
Topic	5.3 Electric Cells
Difficulty	Medium

Exam Papers Practice

To be used by all students preparing for DP IB Physics SL
Students of other boards may also find this useful

Question 1

A resistor R is connected to the terminals of a battery of emf 9.0 V and internal resistance r .

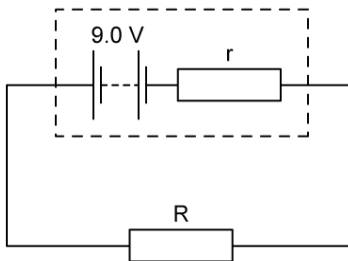

A charge of 240 C through the resistor in two minutes. The power dissipated in the resistor as a result is 1440 J . What is the internal resistance r of the battery?

- A. $3.0\ \Omega$
- B. $2.0\ \Omega$
- C. $1.5\ \Omega$
- D. $4.5\ \Omega$

[1 mark]

Question 2

A battery of electromotive force ϵ delivers charge Q to the load resistance. Which of the following statements is correct?

- A. The chemical work done around the circuit is ϵQ
- B. The electrical work done between the terminals of the battery is ϵQ
- C. The load resistance is ϵQ
- D. The electrical work done in the battery and the across the load resistance is ϵQ

[1 mark]

Question 3

The potential difference across the terminals of a battery is 5.0 V when the current is 1.0 A and 4.0 V when the current is 1.5 A. What is the emf of the battery and its internal resistance?

	emf (V)	internal resistance (Ω)
A.	7.0	2.0
B.	7.0	0.5
C.	3.0	2.0
D.	3.0	0.5

[1 mark]

Question 4

Which of the following statements about discharging cells is incorrect?

- A. The capacity of a cell is proportional to the amount of charge delivered to an external circuit over a cell's lifetime
- B. The lifetime of a cell depends on its capacity
- C. The lifetime of a cell depends on the current it produces
- D. The internal resistance of a cell gradually increases over its lifetime

[1 mark]

Exam Papers Practice

Question 5

An electrical circuit is designed to measure the current I through a variable resistor R . The cell used in the circuit has an emf ϵ and an internal resistance r .

A graph shows the variation of $\frac{1}{I}$ with R .

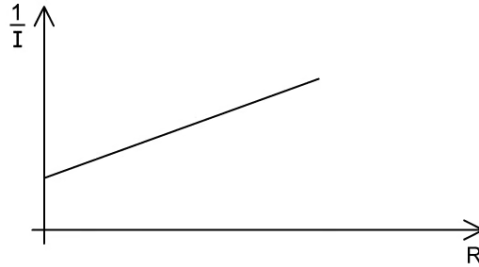

What is the magnitude of the gradient?

- A. $\frac{1}{\epsilon}$
- B. $\frac{1}{R}$
- C. $\frac{1}{r}$
- D. r



[1 mark]

Exam Papers Practice

Question 6

In the circuit shown, a primary cell charges a secondary cell through a pair of resistors.

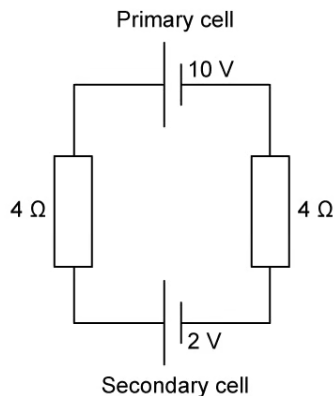

Which of the following statements about the circuit is correct?

- A. Primary cells are rechargeable
- B. The power generated in the primary cell is equal to the power stored in the secondary cell
- C. The current in the circuit is 0.5 A
- D. The power stored in the secondary cell is 20% of the power generated by the primary cell

[1 mark]

Question 7

Which statement about terminal potential difference V and e.m.f. ϵ is incorrect?

- A. For non-ideal batteries, terminal potential difference is always measured to be less than the e.m.f.
- B. $V = \epsilon$ only when current in the cell is zero
- C. For ideal batteries, the terminal potential difference is always measured to be less than the e.m.f.
- D. The terminal potential difference of non-ideal batteries decreases over time

[1 mark]

Question 8

Which of the following units for internal resistance is incorrect?

- A. VA^{-1}
- B. $\text{Js}^{-1}\text{A}^{-2}$
- C. $\text{kgm}^2\text{A}^{-2}\text{s}^{-2}$
- D. $\text{kgm}^2\text{A}^{-2}\text{s}^{-3}$

[1 mark]

Question 9

In the two circuits shown, only the internal resistances differ.

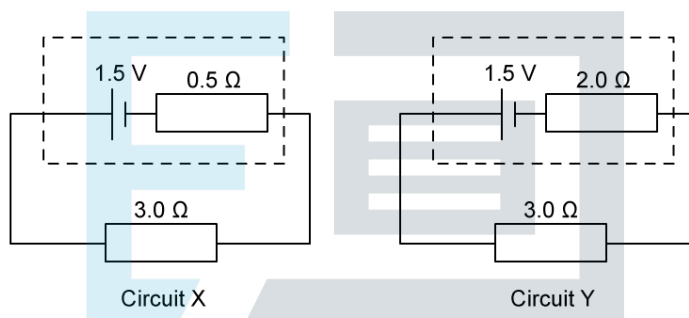

Which row in the table below correctly describes the potential difference across and power dissipated by the 3 Ω resistor?

	potential difference across the 3 Ω resistor (V)	power dissipated in the 3 Ω resistor (W)
A.	Greater in X than in Y	Lesser in X than in Y
B.	Greater in X than in Y	Greater in X than in Y
C.	Lesser in X than in Y	Lesser in X than in Y
D.	Lesser in X than in Y	Greater in X than in Y

[1 mark]

Question 10

A cell of internal resistance r is connected to a variable resistor R .

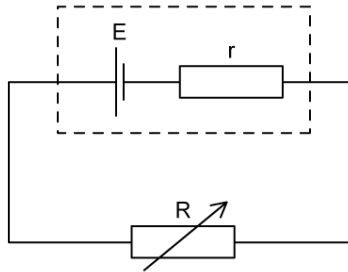

Which of the following statements about the circuit is/are correct?

- (1) If the resistance of R decreases, the terminal potential difference of the cell also decreases, but the power dissipated in the cell is large
- (2) If the resistance of R is made very large, the current in the circuit is very small but most of the power supplied by the cell is dissipated by R
- (3) If the resistance of R is made very small, then the lifetime of the cell reduces

- A. Statement (1) only
- B. Statement (2) only
- C. Statements (1) and (3) only
- D. Statements (1), (2) and (3)

[1 mark]

Exam Papers Practice