

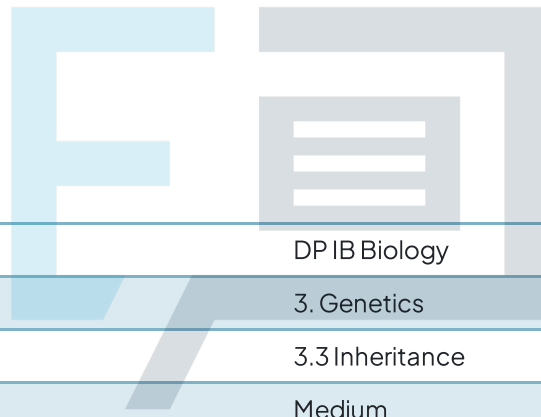

3.3 Inheritance

Question Paper



Course	DP IB Biology
Section	3. Genetics
Topic	3.3 Inheritance
Difficulty	Medium

Exam Papers Practice

To be used by all students preparing for DP IB Biology SL
Students of other boards may also find this useful

Question 1

Through extensive experiments with pea plants, Gregor Mendel was able to show:

- I. The principles of inheritance.
- II. That purebred individuals could be cross-bred to produce a generation of offspring with identical phenotypes.
- III. That mutations within alleles could result in unexpected ratios of offspring.

- A. I only
- B. II only
- C. II and III
- D. I and II

[1 mark]

Question 2

How did Gregor Mendel ensure the reliability of his data?

- A. Repeating his investigation many times.
- B. Collecting large amounts of qualitative data.
- C. Making observations of a pea plant over many years.
- D. Completing a statistical test on his results.

[1 mark]

Exam Papers Practice

Question 3

Which statement best describes the cells produced as a result of meiosis?

- A. Haploid and genetically identical.
- B. Diploid and genetically identical.
- C. Haploid and genetically different.
- D. Diploid and genetically different.

[1 mark]

Question 4

A species of plant can have either blue or white flowers. The colour of the flower is controlled by a single gene where the dominant allele codes for blue flowers.

Two heterozygous plants are crossed; which of the observed outcomes matches up most accurately to the expected ratio of blue to white flowers.

	Blue	White
A	93	46
B	77	203
C	107	33
D	127	42

[1 mark]

Question 5

Two parents have an equal chance of having a child with blood groups A, B, AB, or O.

What are the genotypes of the parents?

- A. AB, AO
- B. AO, BO
- C. AB, OO
- D. AB, AB

[1 mark]

Exam Papers Practice

Question 6

A woman is a carrier of haemophilia; her husband does not have haemophilia.

What are the possible genotypes of their children?

	Sons	Daughters
A	All sufferers	All carriers
B	Half healthy	All carriers
C	Half healthy	All healthy
D	Half healthy	Half carriers

[1 mark]

Question 7

The pedigree diagram shows the inheritance of cystic fibrosis across 3 generations.

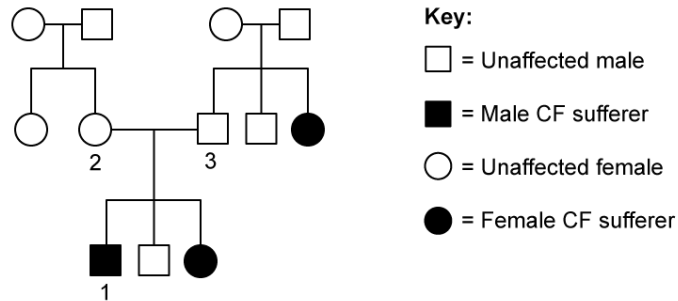

Identify the genotype of the individuals labelled 1, 2 and 3 in the pedigree diagram.

	1	2	3
A	Heterozygous	Homozygous dominant	Heterozygous
B	Homozygous recessive	Homozygous dominant	Heterozygous
C	Homozygous recessive	Heterozygous	Heterozygous
D	Heterozygous	Homozygous recessive	Homozygous dominant

[1 mark]

Question 8

A couple are trying to decide whether their children may be at risk of inheriting Huntington's disease. One parent is heterozygous for Huntingtons and the other is a healthy individual.

Calculate the % chance that their offspring are likely to suffer from the disease.

- A. 50%
- B. 25%
- C. 100%
- D. 75%

[1 mark]

Question 9

The pedigree diagram below shows the inheritance of haemophilia across three generations.

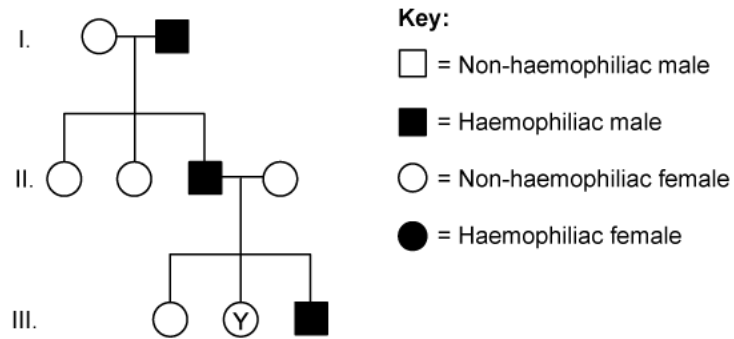

Identify the genotype of person **Y**.

- A. X^hX^h
- B. X^HX^H
- C. X^HX^h
- D. X^HY

[1 mark]

Question 10

Which of the following are mutagenic agents?

- A. X-rays, benzo(a)pyrene, radio waves
- B. X-rays, microwaves, radio waves
- C. X-rays, benzo(a)pyrene, gamma rays
- D. X-rays, benzo(a)pyrene, microwaves

[1 mark]