



## Exam Papers Practice

Boost your performance and confidence with these topic-based exam questions

Practice questions created by actual examiners and assessment experts

Detailed mark schemes

Suitable for all boards

Designed to test your ability and thoroughly prepare you

### 3.1 Genes & Chromosomes



# IB Biology - Revision Notes

---

[www.exampaperspractice.co.uk](http://www.exampaperspractice.co.uk)

## 3.1.1 Genes

### Genes & Polypeptides

- A gene is a section or **length of DNA** that codes for a **polypeptide**
- Genes are **heritable factors** that influence specific **characteristics** (via the polypeptides produced)
  - **Characteristic** means a feature of an organism like **height** in pea plants or **blood group** in humans
  - **Heritable** means genes are factors that pass from parent to offspring during reproduction
- A gene occupies a **specific position** on a **chromosome**
- The gene for a particular characteristic is always found at the same position or **locus** (plural is **loci**) on a particular chromosome

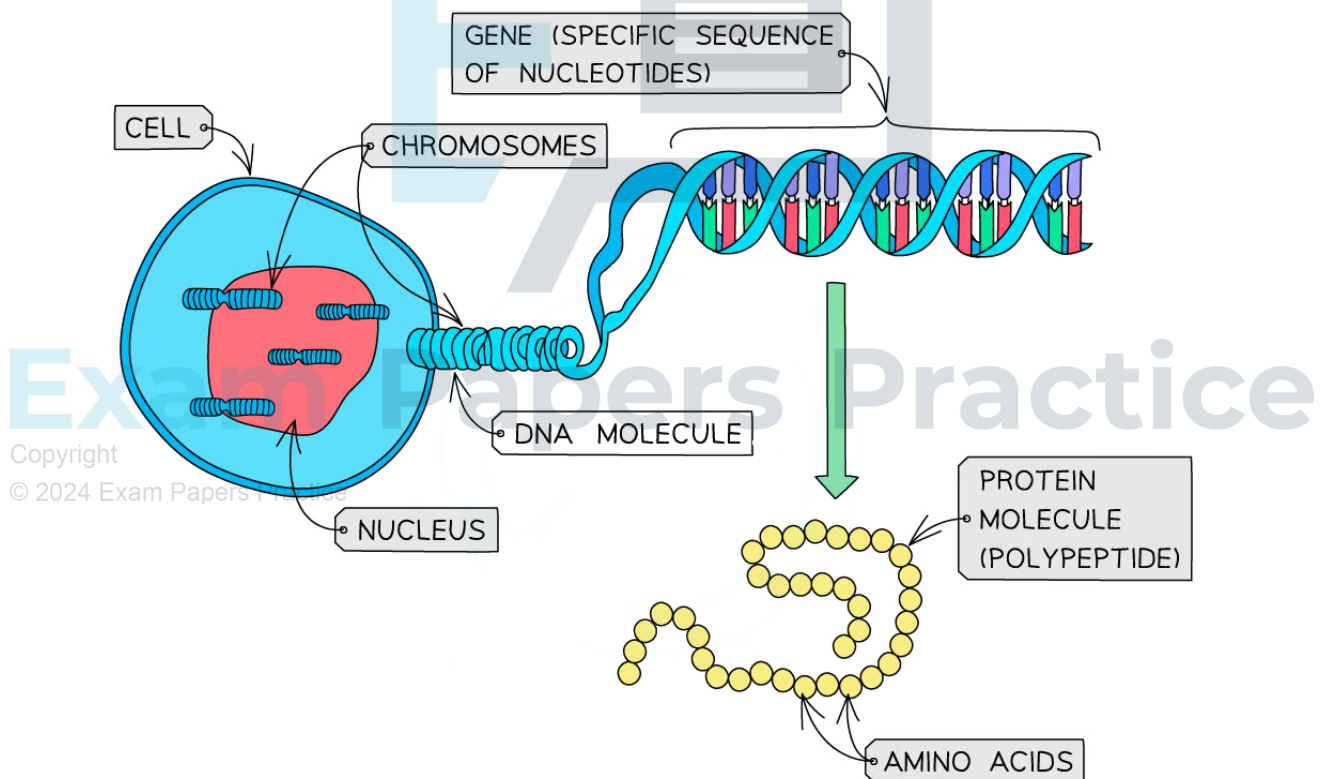

*A gene consists of a length of DNA found in the nucleus. This length of DNA causes a specific characteristic by coding for specific polypeptides.*



### Exam Tip

Remember – each chromosome in a human cell nucleus contains one very long DNA molecule. This DNA molecule is made up of thousands of specific nucleotide sequences called genes that code for specific polypeptides.

## Loci

- A single chromosome contains **several hundred or thousands** of genes
  - Dependent on the length of the chromosome
- Through experiments and genetic mapping techniques, scientists were able to work out the specific **physical location of a gene on a chromosome**
- The location of a gene on a chromosome is known as its **locus** (the plural of locus is loci)
- Each gene occupies **a specific locus** so that the gene for a particular characteristic is always found at the same position on a particular chromosome

## Comparing the Number of Genes

- Species vary in the **number of genes** they have
- The number of genes a species has is **not related** to the size/complexity or even the sophistication of the organism
  - Because genes can vary in length
- **Counting the exact number of genes in a species is difficult**, so you may see conflicting numbers in different sources
- **Humans** have around 20,000 genes
- Dogs have 19,000 genes, which is **less than humans**
- A **water flea** has **more than a human** with 31,000 genes
- *E. coli*, a **bacterium**, has only 4,300 genes
- A rice **plant** has 41,500 genes

Comparing the Number of Genes between Different Organisms Table

Organism	Human	Dog	Water flea	Bacterium E.coli	Rice plant
Approximate number of genes	20,000	19,000	31,000	4300	41,500

### Exam Tip

For the comparison of the number of genes you need to know at least one plant and one bacterium, and at least one species with **more than humans** and one species with **fewer genes than humans**. The "number of genes" should not be referred to or confused with "genome size" as this term is used for the total amount of DNA (usually measured in the number of base pairs). Much of a eukaryotic species' genome does not code for polypeptides.

## 3.1.2 Alleles

### Alleles

- A gene codes for a specific polypeptide that can affect a specific trait or characteristic in an organism
  - Eg. blood type
- **Alternative forms of a gene** can exist, these various specific forms are called **alleles**
  - Note that although alleles are different forms of the same gene, they all still occupy the same locus on the chromosome
  - New alleles occur through **mutations**
- **Multiple alleles** can exist for a gene that determines a specific trait
  - Each allele results in a different variation of that trait
    - Eg. blood types A, B, AB and O
- The chromosomes of eukaryotic cells occur in **homologous pairs** (there are two copies of each chromosome, one copy inherited from each parent) which means that cells have **two copies of every gene**
  - As a result, a cell possesses **two alleles of every gene** within its nucleus
  - When the two alleles at a locus are the **same/identical** they are described as **homozygous**
  - When the two alleles at a locus are **different** they are described as **heterozygous**

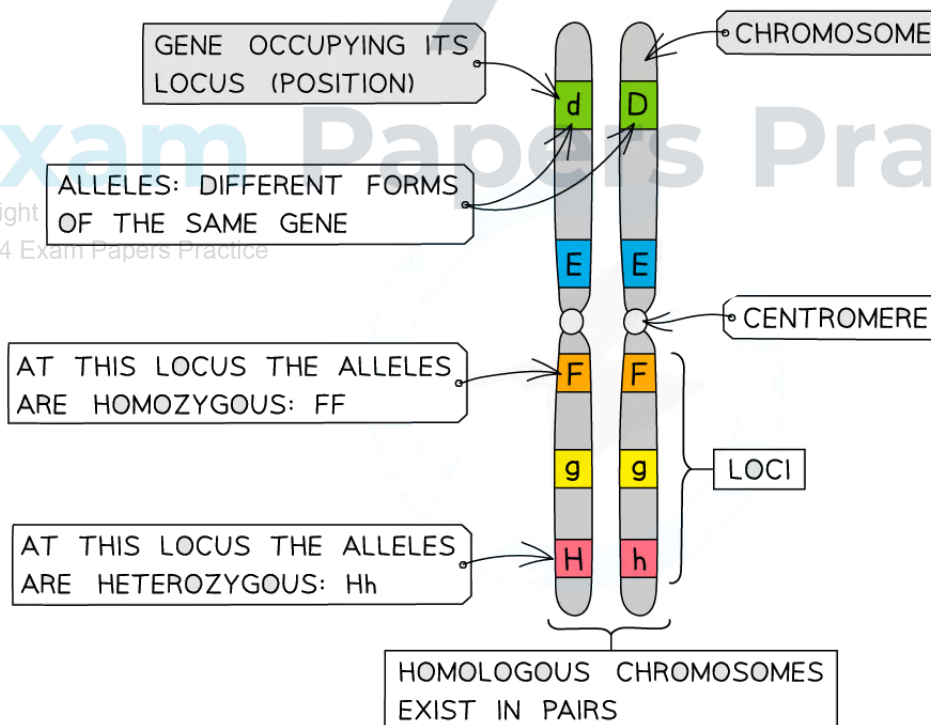

*Chromosomes showing genes, loci and alleles*

## Differences between Alleles

- Alleles differ from each other by **one or only a few bases**
- Even a very small change in base sequence can bring about a large effect in gene function, with a large knock-on effect on the **phenotype**
- Even though different alleles of a gene have slightly **different base sequences**, they still occupy the **same locus** on the chromosome
- Since the Human Genome Project, **sophisticated techniques** can analyse different alleles
- These techniques are becoming **faster, more accurate** and **more accessible** to individuals
  - Comparable sequences can be analysed down to individual bases to determine **evolutionary relationships**
  - The more differences in base sequence, the further apart two species are in evolutionary terms
- The exact positions where bases differ between alleles are called **SNPs** or **snips** (Single Nucleotide Polymorphisms)
  - An allele **can have several snips** but still only **differ by a few bases** from its other allele

### Exam Tip

Use the term **allele** wherever possible in written answers, as it's always a more precise term than **gene**.



### 3.1.3 Mutation

#### Mutation

- A **gene mutation** is a change in the sequence of base pairs in a DNA molecule; this may result in a new allele
  - Mutations occur **all the time** and **at random**
  - There are certain points in the cell cycle when mutations are more likely to occur, for example, **copying errors** when DNA is being replicated (S phase of interphase)
- As the DNA base sequence determines the sequence of amino acids that make up a polypeptide, **mutations in a gene** can sometimes lead to a **change in the polypeptide** that the gene codes for
- Most mutations are **harmful** or **neutral** (have no effect) but some can be **beneficial**
- **Inheritance** of mutations:
  - Mutations present in normal body cells are **not inherited**, they are eliminated from the population once those cells die
  - Mutations within **gametes** are inherited by offspring, possibly causing genetic disease

#### Substitution mutations

- A mutation that occurs when a base in the DNA sequence is **randomly swapped** for a different base is known as a **substitution mutation**
- A substitution mutation will only change the amino acid for the triplet (group of three consecutive bases) where the mutation occurs; it will **not have a knock-on effect** further along the gene/polypeptide

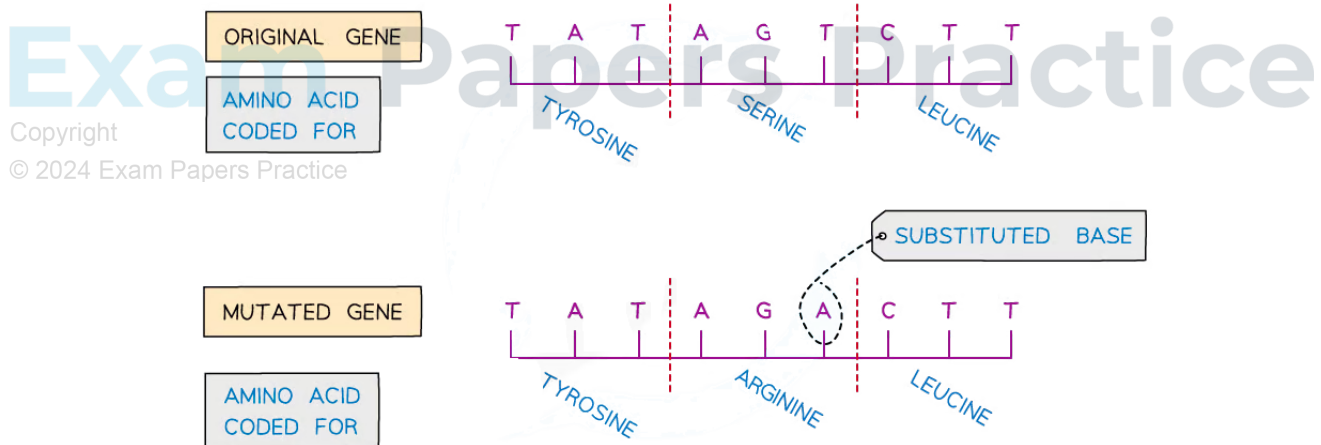

*An example of a substitution mutation altering the sequence of amino acids in the polypeptide*

#### Exam Tip

You don't need to know about deletions, insertions and frameshift mutations - just **substitution** mutations!

## Sickle Cell Anaemia

- A small change to a gene can have **serious consequences** for an organism
- Sickle cell anaemia is a genetic disease caused by a **single base substitution mutation** within the gene (*Hb*) that codes for the alpha-globin polypeptide in haemoglobin
  - Most humans have the normal allele **Hb<sup>A</sup>**

### The mutation that occurs

- Within the haemoglobin gene, the base thymine (T) is **replaced by the base adenine (A)**. This causes the DNA triplet **GAG** to mutate to **GTG**
- The mutated DNA codon **GTG** is transcribed into the **mRNA codon GUG**, instead of **GAG**
- During translation the amino acid **valine (VAL)** replaces the original amino acid **glutamic acid (GLU)**; this occurs on the **sixth position** of the polypeptide
- The slightly different polypeptide results in a new allele, **Hb<sup>S</sup>**

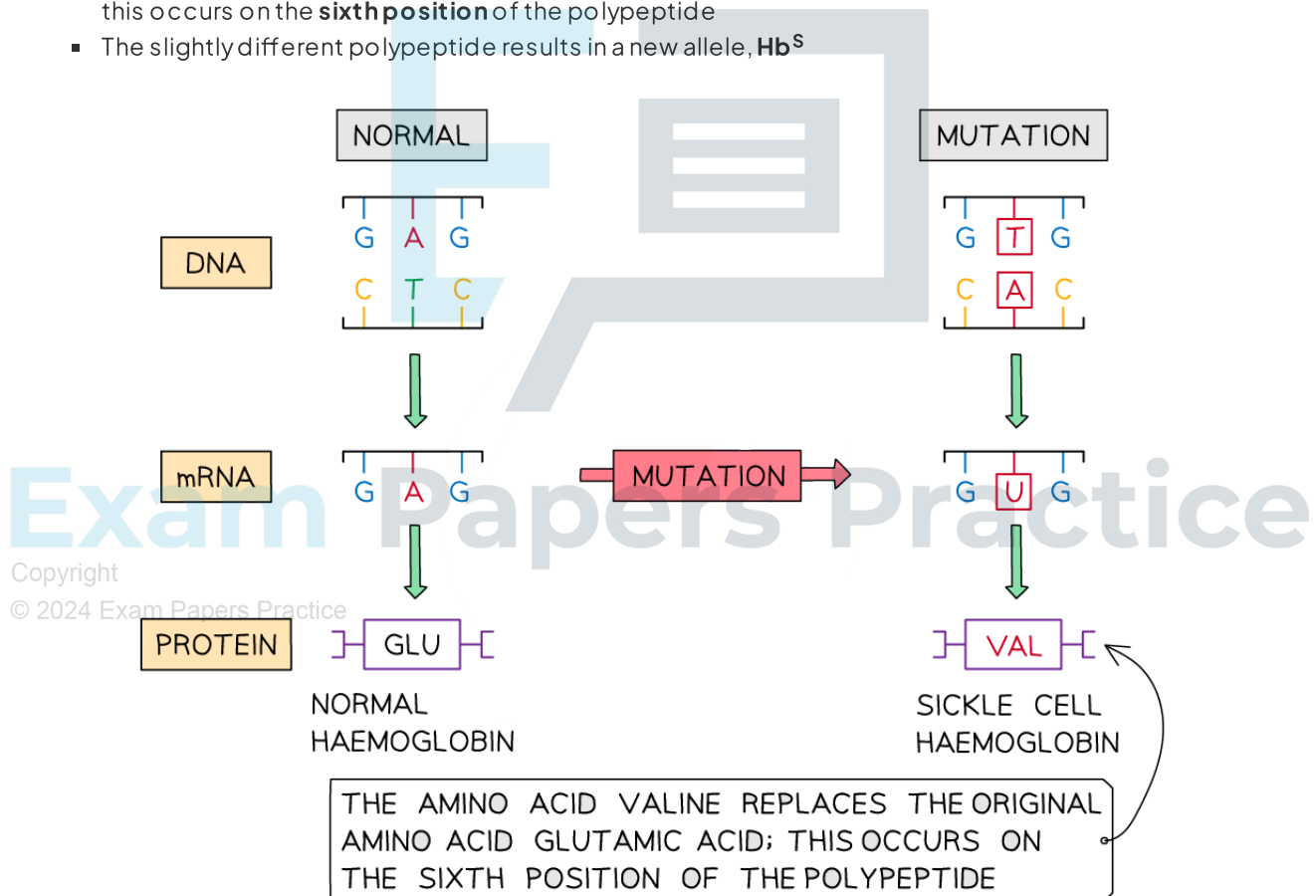

***A base substitution on the DNA molecule results in a change in the amino acid at position 6 of the haemoglobin polypeptide, altering the overall structure and function of the protein***

### The effects

- The protein haemoglobin **S** is produced instead of haemoglobin **A**; this causes a **distortion in the shape of the red blood cells** into **sickle shapes**
- Sickle-shaped red blood cells:
  - Have a **limited oxygen-carrying capacity**
  - **Block the capillaries** limiting the flow of normal red blood cells
- People with sickle cell anaemia suffer from **acute pain, fatigue** and **anaemia**
- There is a **correlation** between **sickle cell anaemia** and **malaria**
  - In areas with increased malaria cases, there is an increased frequency of sickle cell alleles

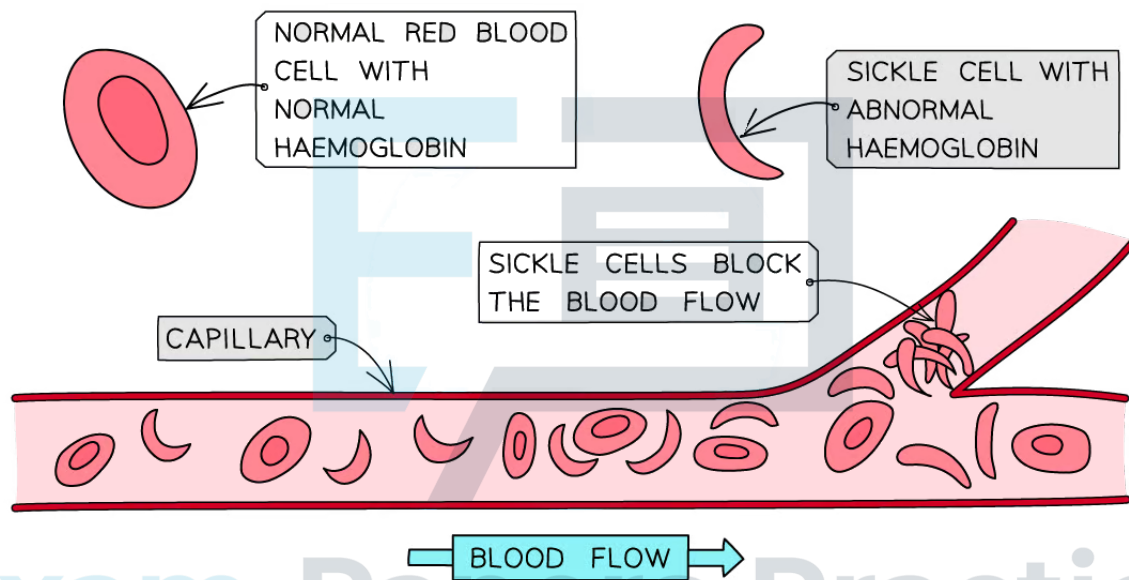

Exam Papers Practice

Copyright © 2024 Exam Papers Practice  
 Normal red blood cells and sickle cell blood cells. The sickle cells cause a blockage in the capillary, restricting blood flow.

## 3.1.4 Genome

### Genome



- The **total of all the genetic information in an organism** is called the **genome** of the organism
- This is a **complete set of genes** present within every cell of an organism
- This includes **all genes** as well as non-coding DNA sequences
- **Mitochondrial DNA** and **chloroplast DNA** are included in the genome
- In a prokaryote cell, **plasmid DNA** is included in its genome



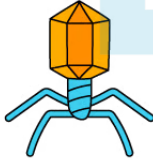
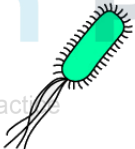

## Comparing Genome Size

- Advances in technology have allowed scientists to **write the whole sequence** of the genes within an organism's genome
- Genome-wide comparisons can now be made **between individuals** and **between species**
- Sequencing projects have read the **genomes of a wide range of organisms** from bacteria to humans
- Genome sizes can differ in different organisms:
  - Viruses and bacteria tend to have **very small genomes**
  - Prokaryotes tend to have smaller genomes than eukaryotes
  - The size of **plant genomes can vary widely**

Comparing the Genome Size of Different Organisms Table

Organism	Common names	Genom Size (in million base pairs)
T2 Phage 	Virus that attacks E.coli	0.17
E. coli 	Bacterium	5
Drosophila melanogaster 	Fruit Fly	140



<b>Homo sapiens</b> 	Human	3000
<b>Paris japonica</b> 	Woodland Plant	150,000

# Exam Papers Practice

Copyright

© 2024 Exam Papers Practice

## Human Genome Project

- The Human Genome Project (HGP) was an **international, collaborative, research programme** to sequence the entire human genome
- The work began in 1990, was **publicly funded**, and **shared** among more than 200 laboratories around the world, avoiding duplication of effort
  - Different labs sequenced different chromosomes
- DNA samples were taken from multiple people around the world, sequenced, and used to create a **reference genome**
- Because of rapid improvements in base sequencing technology the project finished ahead of time and was **published in April 2003**
- The finished genome was over **3 billion base pairs long** but contained only about 25,000 genes
- The HGP discovered new data about **non-coding DNA**, suggesting that it plays an active role in the cell, and that it isn't just 'junk' DNA
- The sequence of the DNA is stored in databases available to anyone on the Internet
- At the same time as the HGP, teams of scientists set about the **sequencing of the DNA of other organisms**. This included the human gut bacterium, *E. coli*, the fruit fly and the mouse. Since then, more than 30 non-human genomes have been sequenced

## Applications of the Human Genome Project

- Three key impacts of the HGP include:
  - **How many individual genes** we have and how they work
  - Locating the **cause of genetic disorders**
  - Development of the new discipline of **bioinformatics** (the storage, manipulation and analysis of biological information via computer)
- The sequencing of the human genome has shown that **all humans share the vast majority (99.9%) of their base sequences**, but also that there are many **SNPs** that contribute to human diversity
- The information generated from the HGP has been used to tackle human health issues with the **end goal of finding cures for diseases**
- Scientists have noticed a correlation between **changes in specific genes** and the **likelihood of developing certain inherited diseases**
  - Several genes within the human genome have been linked to increased risk of certain **cancers**
  - There have also been specific genes linked to the development of **Alzheimer's disease**
- **Ethical, legal and social issues** are generated by the project

## Genome Sequencing Techniques

**NOS: Developments in scientific research follow improvements in technology; gene sequencers, essentially lasers and optical detectors, are used for the sequencing of genes**

- In scientific research, **critical developments often follow improvements in scientific apparatus**
- For example, distant objects in Space often remain **undiscovered** until a telescope (or some other piece of equipment) powerful enough to detect them is developed
- The fact that scientific research is often held back by a lack of sufficiently powerful or precise apparatus is a problem that will continue into the future
- In some ways, this is very exciting, as it suggests that our scientific knowledge and understanding of the universe will continue to expand as new scientific techniques and technologies are developed
- Investigations such as the Human Genome Project are **dependent on the use of powerful computers and improvements in technology** to store and analyse vast quantities of **data**
- To sequence a genome:
  - The entire genome is **broken up into manageable pieces** and then the **fragments are separated** so that they can be sequenced individually
  - Single-stranded copies are made
  - Nucleotides are each tagged with a differently **coloured fluorescent marker**, one for each base, adenine, cytosine, guanine and thymine
  - Samples are **separated according to length**, by **capillary electrophoresis machine**. This procedure is **very high resolution** and distinguishes DNA fragments that differ in size by only a single nucleotide
  - After separation, a **laser beam makes the fluorescent markers fluoresce**
  - Then an **optical detector** linked to a **computer** deduces the base sequence from the sequence of colours detected
- This process highlights the use of a database to **determine differences in the base sequence of a gene** in two species

Copyright

© 2024

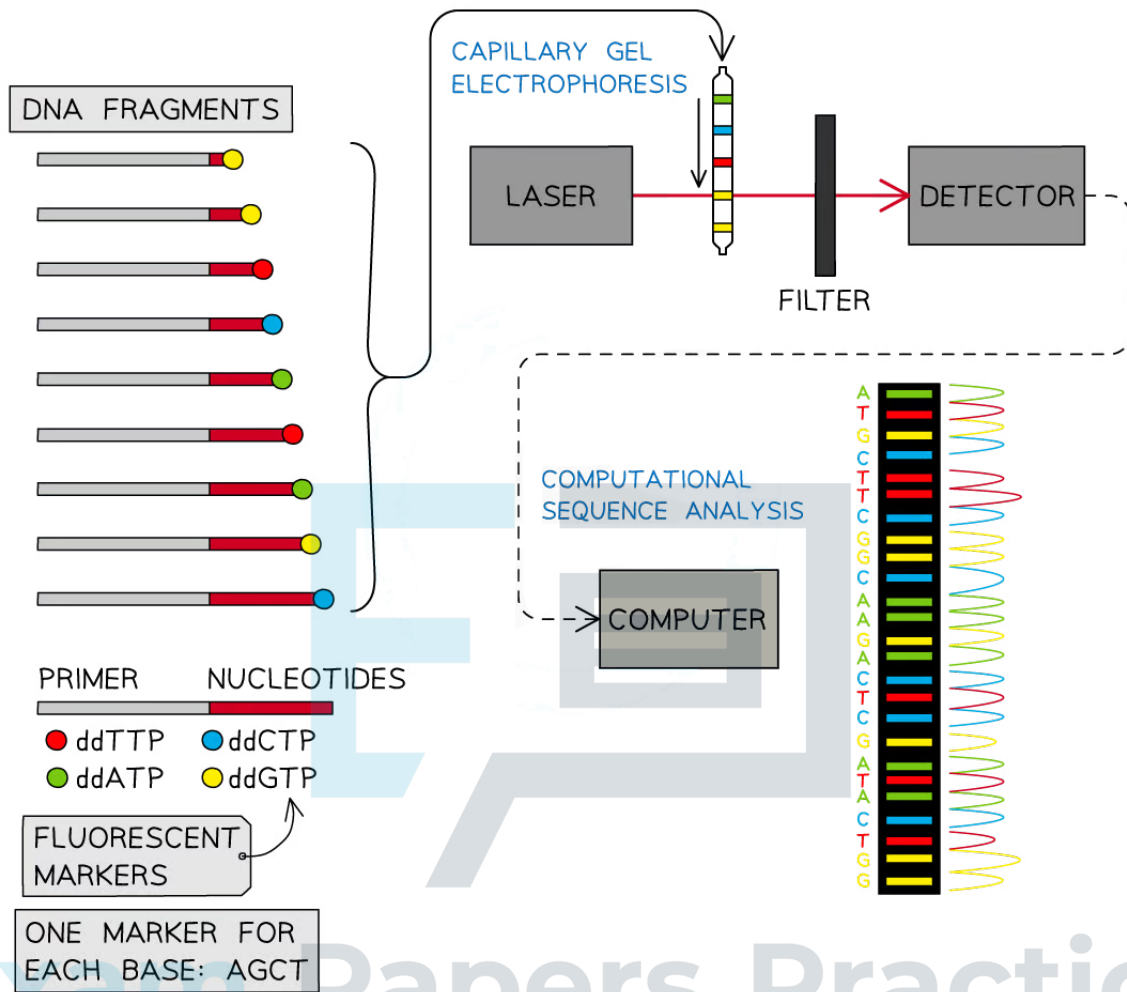

Copyright © 2024 Exam Papers Practice  
*Gene sequencing is made possible by the use of optical laser technology, optical detectors, and computers*

### 3.1.5 Prokaryotic Chromosomes

#### Prokaryotic Chromosomes

- The DNA in prokaryotic cells is significantly different from the DNA found in eukaryotic cells
- Prokaryotes **do not contain a nucleus** therefore the DNA is located in the cytoplasm of the cell
- Prokaryotic DNA consists of a **single, circular chromosome**
  - It is sometimes referred to as a **nucleoid**
- The DNA within prokaryotic cells is **not associated with any proteins**
  - Prokaryotic DNA is sometimes referred to as **naked**
  - Eukaryotic DNA associates with **histone** proteins

## Plasmids

- Prokaryotes also usually have one or more **plasmids**
  - Most eukaryotes do not contain plasmids
  - **Yeast** are the only types of eukaryotes that contain plasmids similar to those in prokaryotes
- Plasmids are **very small circular DNA molecules**
  - They usually **only contain a few genes**
  - They are **short**, typically 100,000 base pairs in length
- They are **more accessible for proteins** required for gene expression and therefore contain genes that are required often, quickly and/or in emergencies
- Plasmids can sometimes be **passed 'sideways' from one cell to another**, outside of the normal inheritance pattern during cell division
- They can also be used as a **vector** during genetic engineering to transfer DNA between species

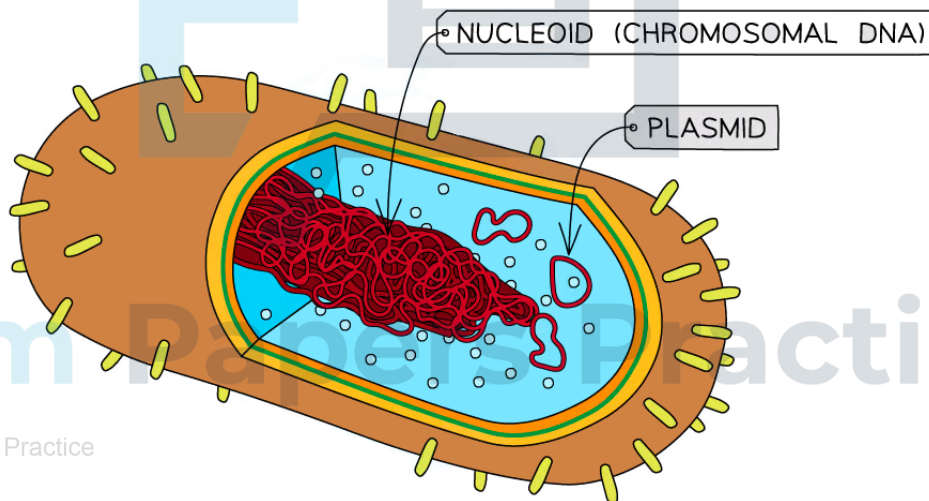

Copyright

© 2024 Exam Papers Practice

*Image showing the arrangement of DNA within a prokaryotic cell*

## Autoradiography

**NOS: Developments in scientific research follow improvements in techniques; autoradiography was used to establish the length of DNA molecules in chromosomes**

- In scientific research, **critical developments often follow improvements in scientific apparatus**
  - For example, distant objects in Space often remain undiscovered until a telescope (or some other piece of equipment) powerful enough to detect them is developed
- The fact that scientific research is often held back by a lack of **sufficiently powerful or precise apparatus** is a problem that will continue into the **future**
- In some ways, this is very exciting, as it suggests that our scientific knowledge and understanding of the universe will **continue to expand** as new scientific techniques and technologies are developed
- **Autoradiography** is a technique used to **study DNA** by **labelling** it using **radioactive isotopes**
  - These isotopes were fed to *E. coli* bacteria which incorporated them into their DNA
- When exposed to a **photographic film** the radioactive isotopes caused the film to become developed, resulting in an **image of the DNA** being produced
- In order to do this scientists use a **radioactive version of the DNA base thymine**, due to the fact this isn't found in RNA
  - The reason why the thymine is radioactive is because it contains **tritium**, a radioactive isotope of hydrogen
  - If scientists want to study RNA (for example, during the process of transcription) they can **use a radioactive version of uracil instead**, as this is not found in DNA
- This technique can be used to study DNA in both eukaryotes and prokaryotes
- In the past, this technique has been used to **make new discoveries about the length and shape of DNA in different organisms**

Copyright

© 2024 Exam Papers Practice

## Cairns' Experimental Technique

### Cairns' technique for measuring the length of DNA molecules by autoradiography

- John Cairns was a scientist working in the field of molecular genetics and cancer research in the 1960s
  - During this time he pioneered a technique of using **autoradiography** to **study the DNA of *E. coli* to determine its length and shape**
- The method that Cairns used is as follows:
  - He first kept the *E. coli* bacteria in a nutrient broth containing a tritiated thymidine which is a **radioactive version of the DNA base thymine** attached to a deoxyribose sugar
  - The *E. coli* bacteria incorporated these bases into their DNA during **replication**. This meant that after several generations the DNA was fully radioactive
  - He then **lysed the cells** using an enzyme called **lysozyme**, breaking apart the **cell walls**, which allowed the DNA to be accessed
  - The DNA was fixed into position onto a membrane
  - The membrane was **submerged in a photographic emulsion** containing silver ions ( $\text{Ag}^+$ ) for two months
  - When the silver ions were exposed to the radioactive DNA, the ions were reduced to silver metal. The grains of silver metal caused **visible black dots** to appear in the **photographic emulsion**
  - Once this emulsion had been developed it could be viewed under an **electron microscope** and the length and shape of DNA could be studied
- By using this technique Cairns made many important discoveries
  - He found that *E. coli* contains a **single, circular chromosome of DNA**
  - He also measured the length of the circular chromosome to be **1100 $\mu\text{m}$  long** (550 times bigger than the *E. coli* cell itself)
- Cairns later went on to make important discoveries about the method of **DNA replication** in prokaryotes using this same technique

Copyright

© 2024 Exam



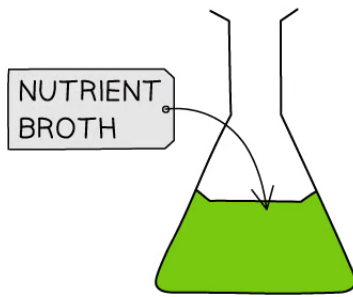

NUTRIENT BROTH

A BROTH IS CREATED CONTAINING RADIOACTIVELY LABELLED THYMINE AND *E. coli* BACTERIA

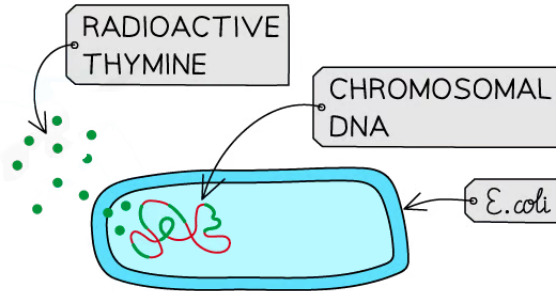

RADIOACTIVE THYMINE

CHROMOSOMAL DNA

*E. coli*

THE *E. coli* BACTERIA TAKE IN THE THYMINE AND USE IT FOR DNA REPLICATION, CAUSING THEIR DNA TO BECOME RADIOACTIVE

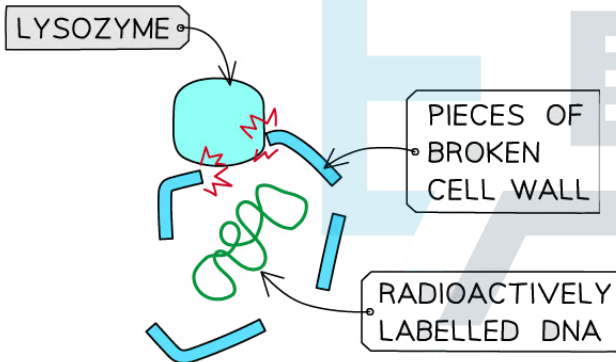

LYSOZYME

PIECES OF BROKEN CELL WALL

RADIOACTIVELY LABELLED DNA

ONCE ADDED, THE ENZYME LYSOZYME BREAKS APART THE CELL WALL OF THE *E. COLI*

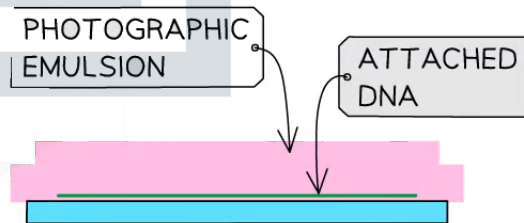

PHOTOGRAPHIC EMULSION

ATTACHED DNA

THE DNA IS ATTACHED TO A MEMBRANE AND SOAKED IN PHOTOGRAPHIC EMULSION

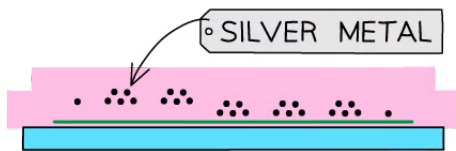

SILVER METAL

THE SILVER IONS IN THE EMULSION ARE REDUCED TO SILVER METAL BY THE RADIOACTIVE THYMINE IN THE DNA



THIS PRODUCES AN IMAGE OF THE DNA, ALLOWING IT TO BE VIEWED UNDER AN ELECTRON MICROSCOPE

The Cairns' technique of using autoradiography to view DNA

## 3.1.6 Eukaryotic Chromosomes

### Eukaryotic Chromosomes

- Chromosomes in eukaryotic cells are **one, very long** DNA molecule associated with proteins
  - The main proteins present are the large, positively charged globular proteins called **histones**, their role is to **organise** and **wrap** the DNA tightly so that it fits into the nucleus
  - The other proteins are **enzymes** used in copying and repairing the DNA
- The tightly coiled combination of DNA and proteins is called **chromatin** – this is what chromosomes are made of

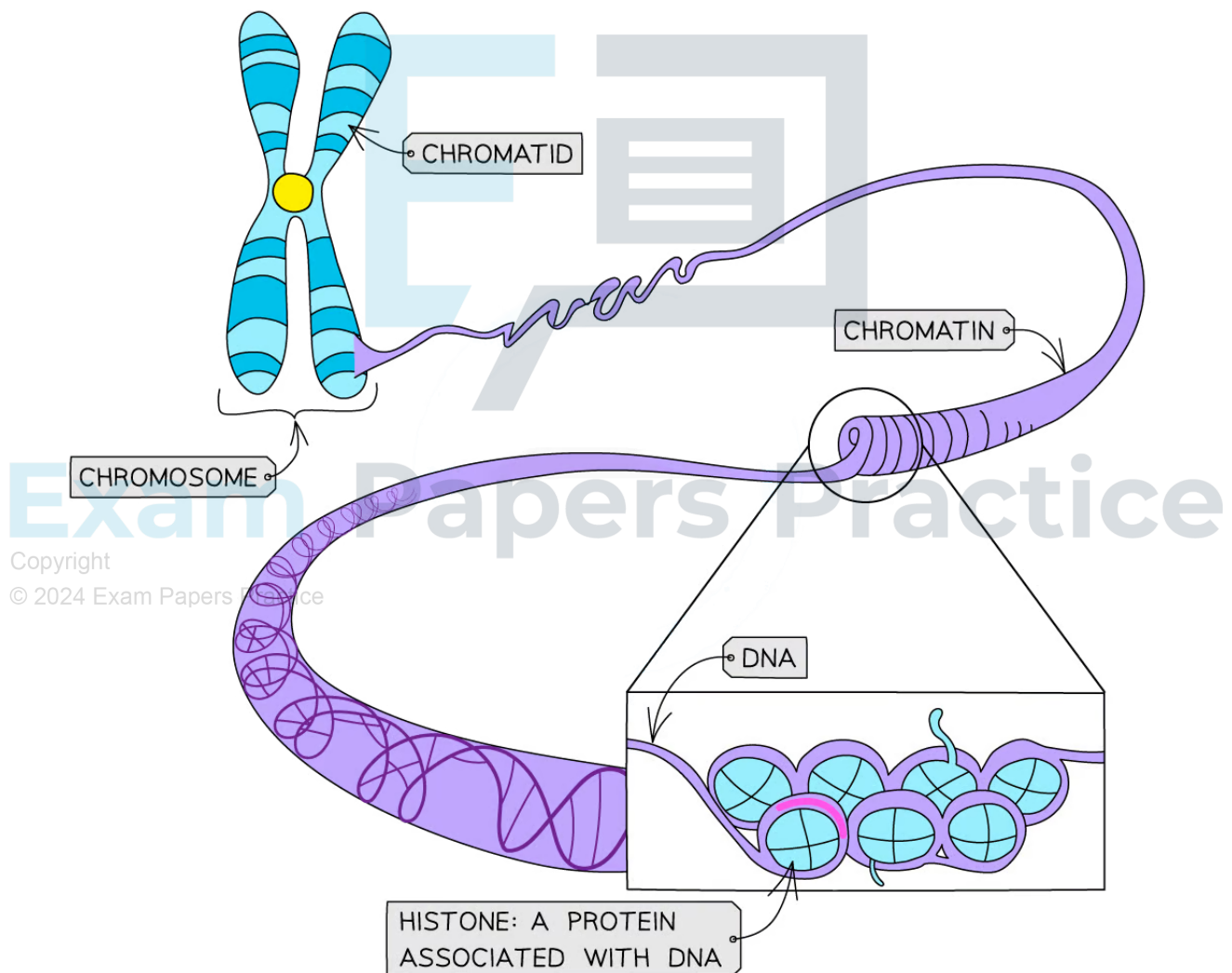

*DNA is coiled around histone proteins to form chromatin*

## The replication of chromosomes

- During **interphase** (the period before mitosis) the DNA replicates to create **two identical strands of DNA called chromatids**, joined together by a narrow region called the **centromere**
- The two chromatids that make up the double structure of a chromosome are known as '**sister chromatids**'
- It is important that the **sister chromatids** are **identical** in order to produce **genetically identical** daughter cells via mitosis
  - During **anaphase** of **mitosis** one chromatid ends up in one daughter cell while the other chromatid ends up in the other daughter cell
- After the centromere is split apart at the start of anaphase the chromatids are referred to as individual **chromosomes** again

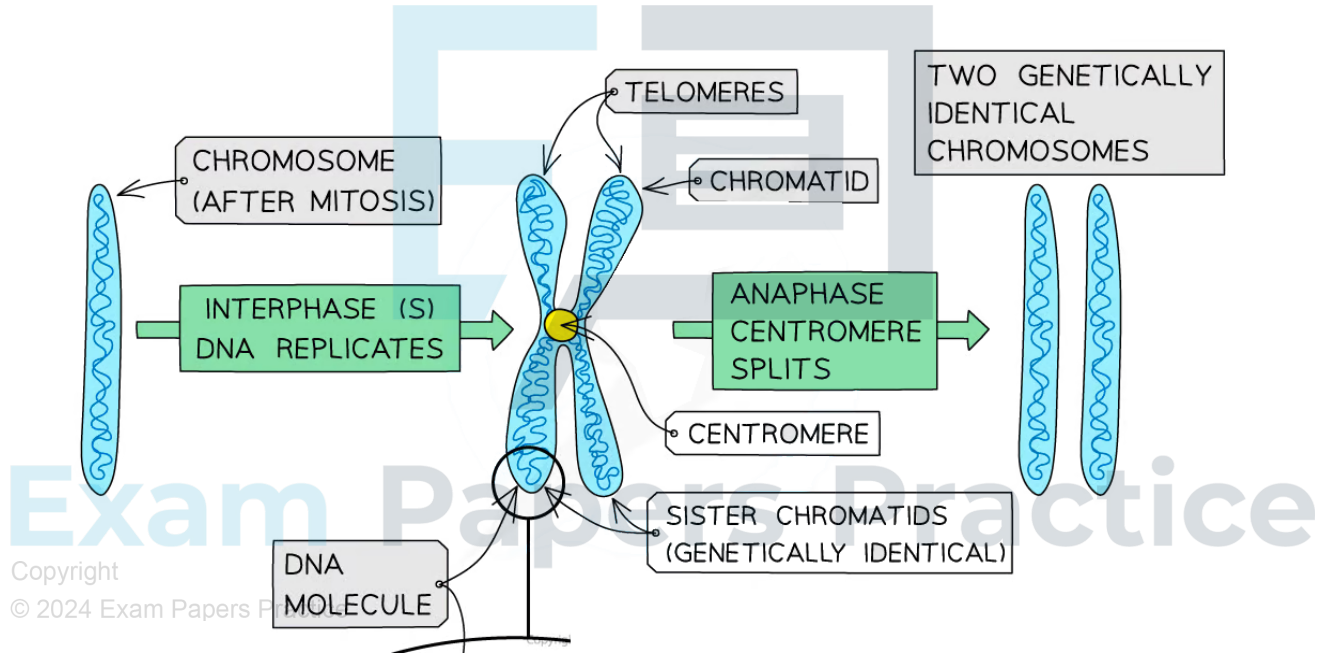

Copyright  
© 2024 Exam Papers Practice

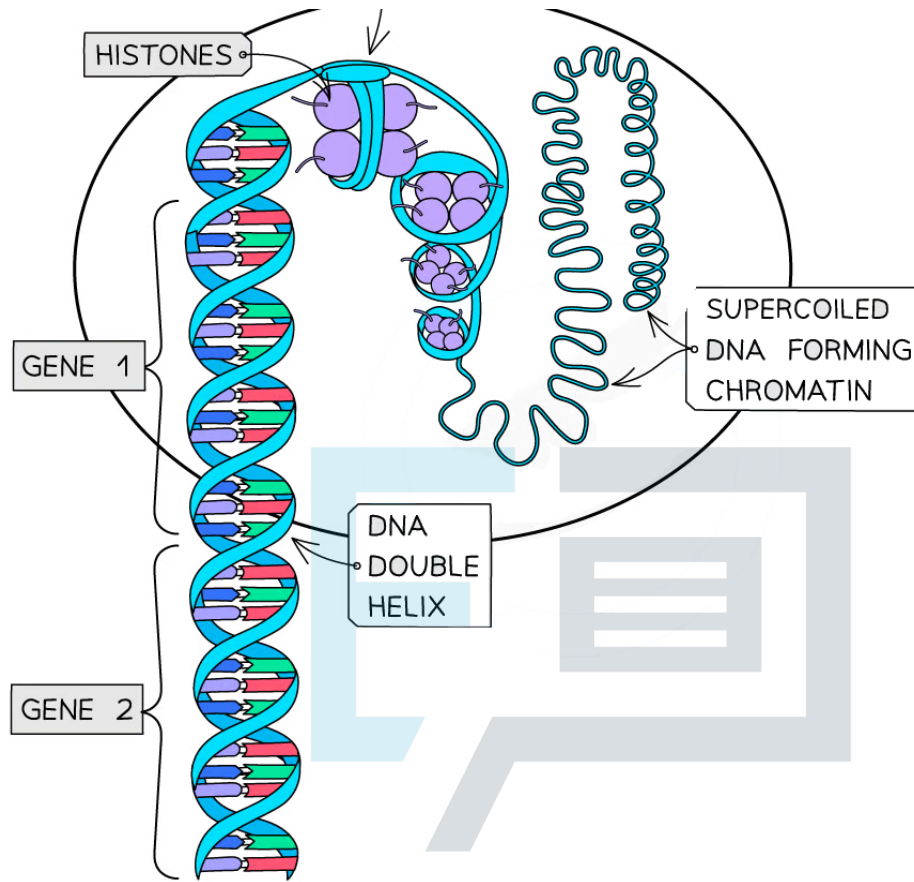

Diagram illustrating the structure of a chromosome at different stages of mitosis

Copyright © 2024 Exam Papers Practice

**Exam Tip**

It is important to distinguish between the terms chromatid, sister chromatids and chromosomes.

## Different Types of Chromosomes

- In a eukaryote species, there are different chromosomes that carry different genes
- During mitosis, chromosomes become denser by supercoiling, so **are easier to observe** than when they are in interphase
- Different types of chromosomes can be seen
  - They **differ in length** and the **position of the centromere**
- Humans have **23 types of chromosomes**
  - The largest one is numbered 1
  - The smallest is numbered 22
  - Pair 23 is the pair of sex chromosomes (XX or XY)
- Humans have between **20,000 and 25,000 genes** across all 46 chromosomes
- Specific **genes always appear at the same locus** (position) of a **particular chromosome**, for example:
  - The SRY gene found on the Y chromosome causes the development of male genitalia such as the testes
  - The genes that determine eye colour are located on chromosome 15
  - The gene with a faulty version that leads to the disease cystic fibrosis is located on chromosome 7
- In other words, each chromosome type contains **specific genes arranged in a standard sequence**
  - This property allows for the exchange of genetic material between chromosomes during meiosis

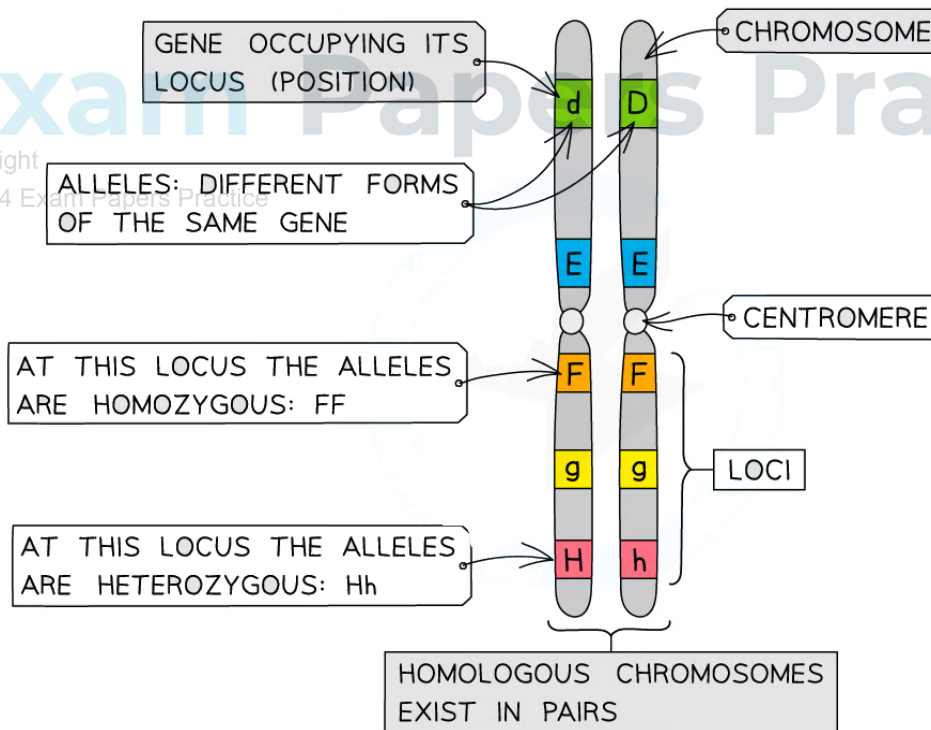

*A pair of homologous chromosomes showing the loci of various alleles*

## Homologous Chromosomes

- In **diploid** cells there are two complete sets of chromosomes in the nucleus
- **Homologous chromosomes**
  - Carry the **same genes at the same loci**
  - Are the **same shape**
  - Are **not usually identical** because they may be carrying **different alleles** to each other
- During fertilization, a diploid zygote is formed
  - In a zygote, one chromosome of each homologous pair comes from the female gamete and the other comes from the male gamete
- Having the same genes in the same **loci** helps homologous chromosomes line up alongside each other during Metaphase I of meiosis
- In photomicrographs, chromosomes are often grouped into their homologous pairs
  - These are shown in a picture format as a **karyogram**

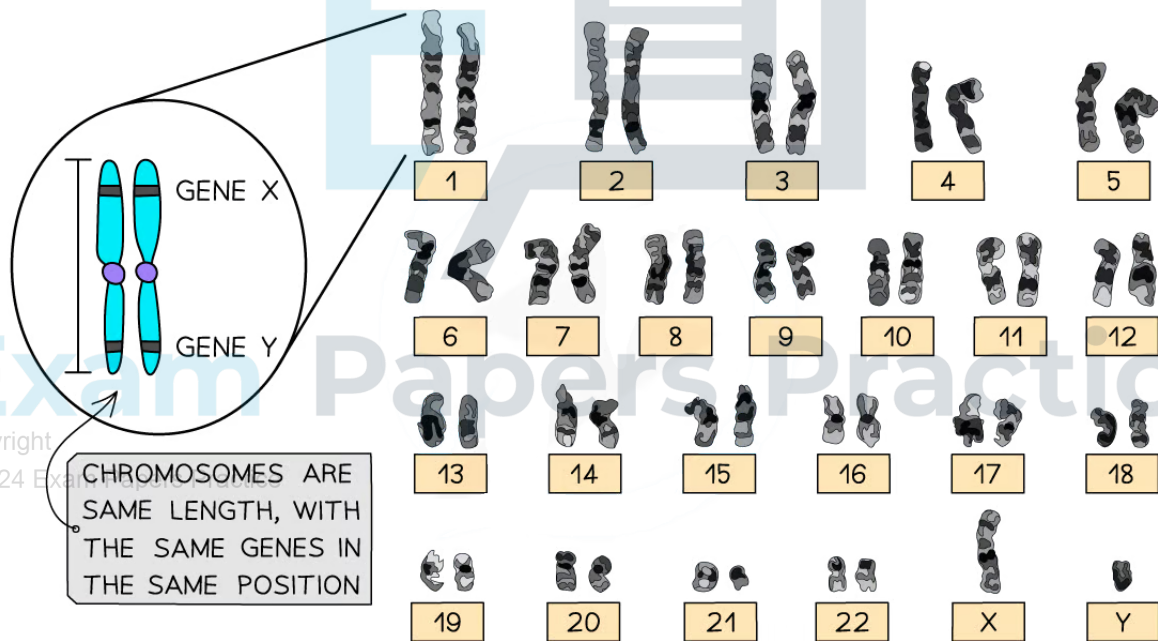

*Human karyogram showing homologous chromosomes*

### Exam Tip

Although homologous pairs of chromosomes contain the same genes in the same order they don't necessarily carry the same alleles (form) of each gene!

## 3.1.7 Chromosome Number

### Haploid

#### Haploid nuclei have one chromosome of each pair

- Haploid cells contain **one complete set of chromosomes (n)**
  - In other words, they have **half** the number of chromosomes compared to normal body cells
  - Humans have **haploid** cells that contain **23 chromosomes** in their nucleus
    - One chromosome from each pair
    - $n=23$
- These haploid cells are called **gametes** and they are involved in sexual reproduction
- In animals, they are the **female egg** and the **male sperm**

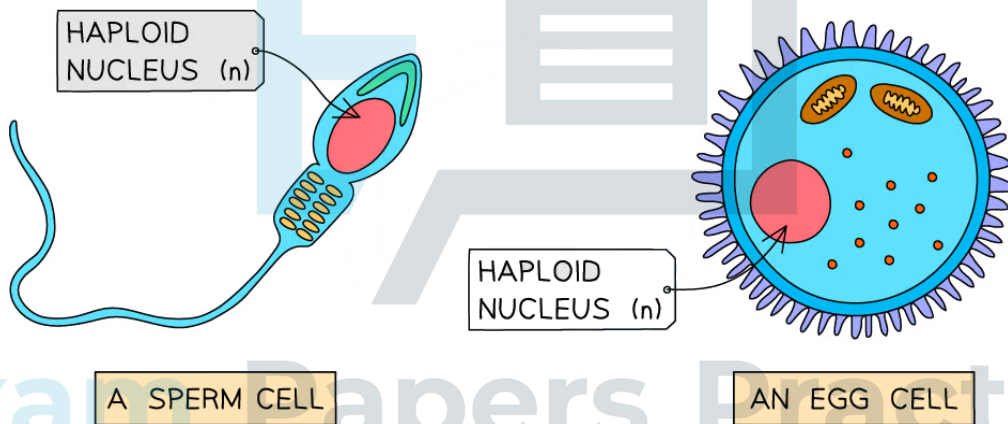

Copyright

© 2024 Exam Papers Practice

*Gametes are haploid cells*

## Diploid

### Diploid nuclei have pairs of homologous chromosomes

- A **diploid** cell is a cell that contains **two complete sets of chromosomes (2n)**
- These chromosomes contain **all the DNA necessary** for protein synthesis and cell function
- A diploid cell (**zygote**) is formed from the **fusion of two haploid gametes** at fertilisation
- Nearly all cells in the human body are **diploid** with 23 **pairs** (46 in total) of chromosomes in their nucleus
  - Red blood cells are an exception to this rule because they do not contain a nucleus
- **2n = 46** in humans
- Having two alleles gives **some protection from harmful mutations** that are **recessive**
  - There is a copy of the correctly-functioning allele still present
- **Hybrid vigour** is often observed in individuals with **two different alleles**, and can be seen as strong growth and general good health

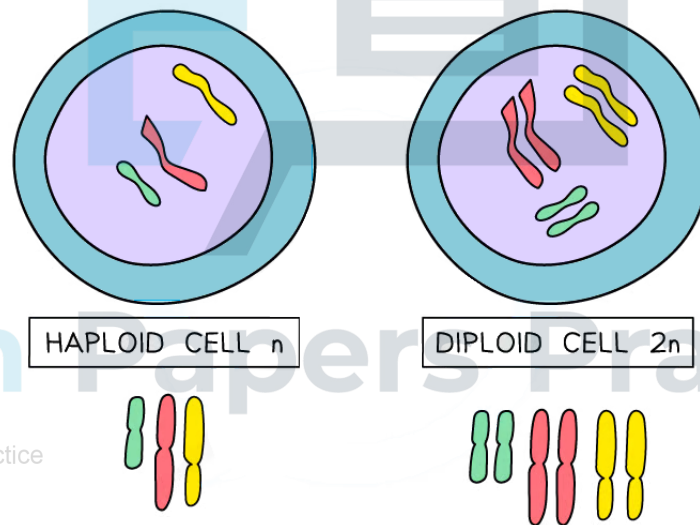

Copyright  
© 2024 Exam Papers Practice

*Haploid (n) and Diploid (2n) cells*



## Number of Chromosomes

The number of chromosomes is a characteristic feature of members of a species

- During fertilisation the **nuclei of gametes fuse together** to form the **nucleus of the zygote**
- Both gametes must contain **the same number of chromosomes** in order for the zygote to be **viable**. If a zygote has too many or too few chromosomes it may not survive
- For a diploid zygote this means that the **gametes must be haploid**
  - $n + n = 2n$
  
- Meiosis produces haploid gametes during sexual reproduction
- The first cell division of meiosis is a **reduction division** (reduces the number of chromosomes)
  - This is a **nuclear division that reduces the chromosome number** of a cell
  - In humans, the chromosome number is reduced from 46 (diploid) to 23 (haploid)
  
- The reduction in chromosome number during meiosis ensures the gametes formed are haploid
- Sometimes during evolution, there can be a **change in the number of chromosomes** a species has; these events are very rare
  - Bread wheat (*Triticum aestivum*) is a species with **six** sets of chromosomes ( $6n$ )
  - These changes didn't occur randomly but were intentionally bred by humans to produce ideal characteristics in the bread wheat

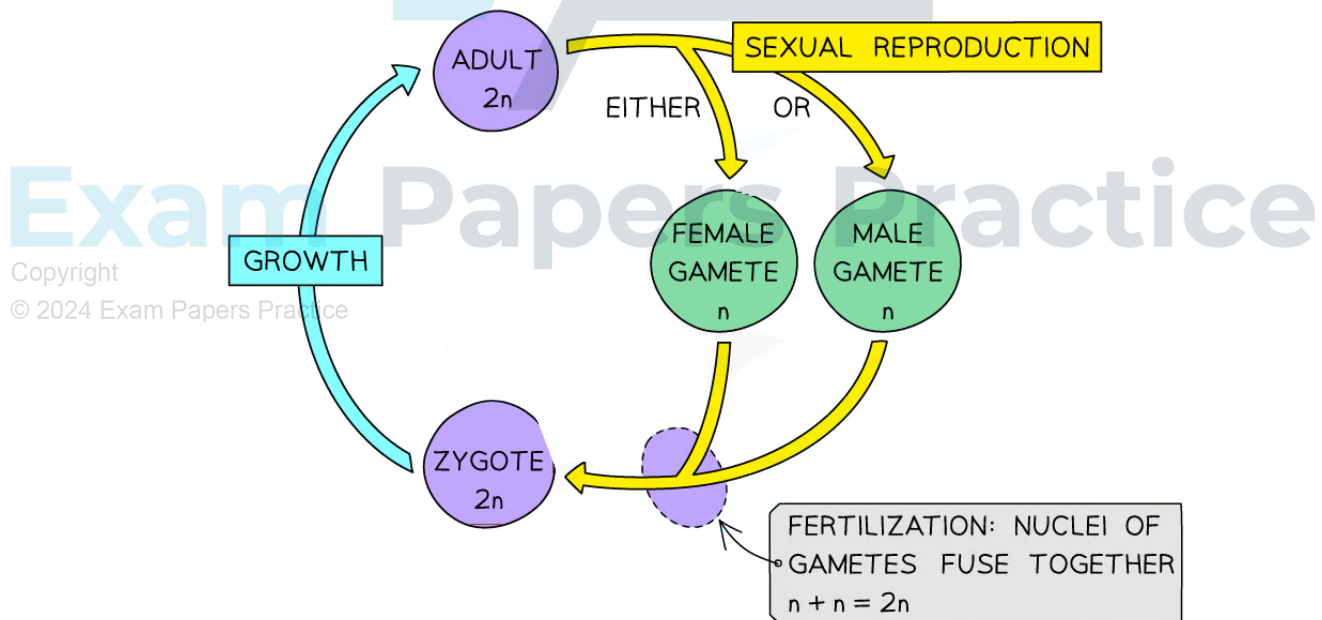

*The maintenance of chromosome number through reduction division in a mammalian life cycle*

## Comparison of Chromosome Numbers

### Comparison of diploid chromosome numbers of humans, chimpanzees, dogs, rice and horse threadworm

- These are their species binomial names
  - *Homo sapiens*, *Pan troglodytes*, *Canis familiaris*, *Oryza sativa*, *Parascaris equorum*
- The number of chromosomes possessed by different species varies and is dependent upon changes that have occurred **during that species' evolution**
- Each individual in a species always has the **same number of chromosomes** (other than in a few rare instances where a chromosome mutation has occurred)
  - **An analogy** is a large, single book containing a trilogy (3) of shorter books; the shorter books could be published separately and still contain the same amount of information
- A **comparison of the chromosome number** of these five selected species can be found below:

Comparison of Chromosome Numbers Table

Name of Species	Diploid Chromosome Number (2n)	Haploid Chromosome Number (n)
Horse threadworm ( <i>Parascaris equorum</i> )	4	2
Rice ( <i>Oryza sativa</i> )	24	12
Human ( <i>Homo sapiens</i> )	46	23
Chimpanzee ( <i>Pan troglodytes</i> )	48	24
Dog ( <i>Canis familiaris</i> )	78	39

- Note that the diploid number must **always** be an **even number**
  - This is because the diploid number (2n) must always be divisible by two to produce the haploid number (n)
  - The haploid number must always be a **whole number**
- An interesting comparison to make is that the number of chromosomes a species possesses is **not linked** to how 'advanced' a species is in evolutionary terms
  - Chimpanzees and dogs have **more chromosomes than humans** even though they have evolved to be less intelligent and complex than humans

### Exam Tip

You may be asked to estimate the number of chromosomes that would be present in the haploid cell of a species. For example, dogs have 78 chromosomes in their diploid cells. When trying to find the number of chromosomes in their haploid cells simply remember that **diploid is  $2n$**  and **haploid is  $n$** , meaning you just need to divide the number of chromosomes by 2. So dogs have 39 chromosomes in their haploid cells!

## 3.1.8 Sex Determination

### Sex Determination

- Sex is determined by an **entire chromosome pair** (as opposed to most other characteristics that are just determined by one or a number of genes)
- **Females** have the sex chromosomes (pair 23 in humans) **XX**
- **Males** have the sex chromosomes (pair 23 in humans) **XY**
  - Note that the rule XX for females and XY for males applies to mammals, but not to all species
- All other chromosomes (pairs 1 - 22 in humans) are **autosomes** and have **no influence on determining the sex** of offspring
- Because only a father can pass on a Y chromosome, he is **responsible for determining the sex of the child**
  - Due to **meiosis**, half of his sperm cells will carry his X chromosome, half his Y chromosome
  - The chromosome carried by **the sperm that fertilizes the egg** will determine the sex of the child
- His daughters receive a copy of his X chromosome
- His sons receive a copy of his Y chromosome

Copyright

© 2024 Exam Papers Practice

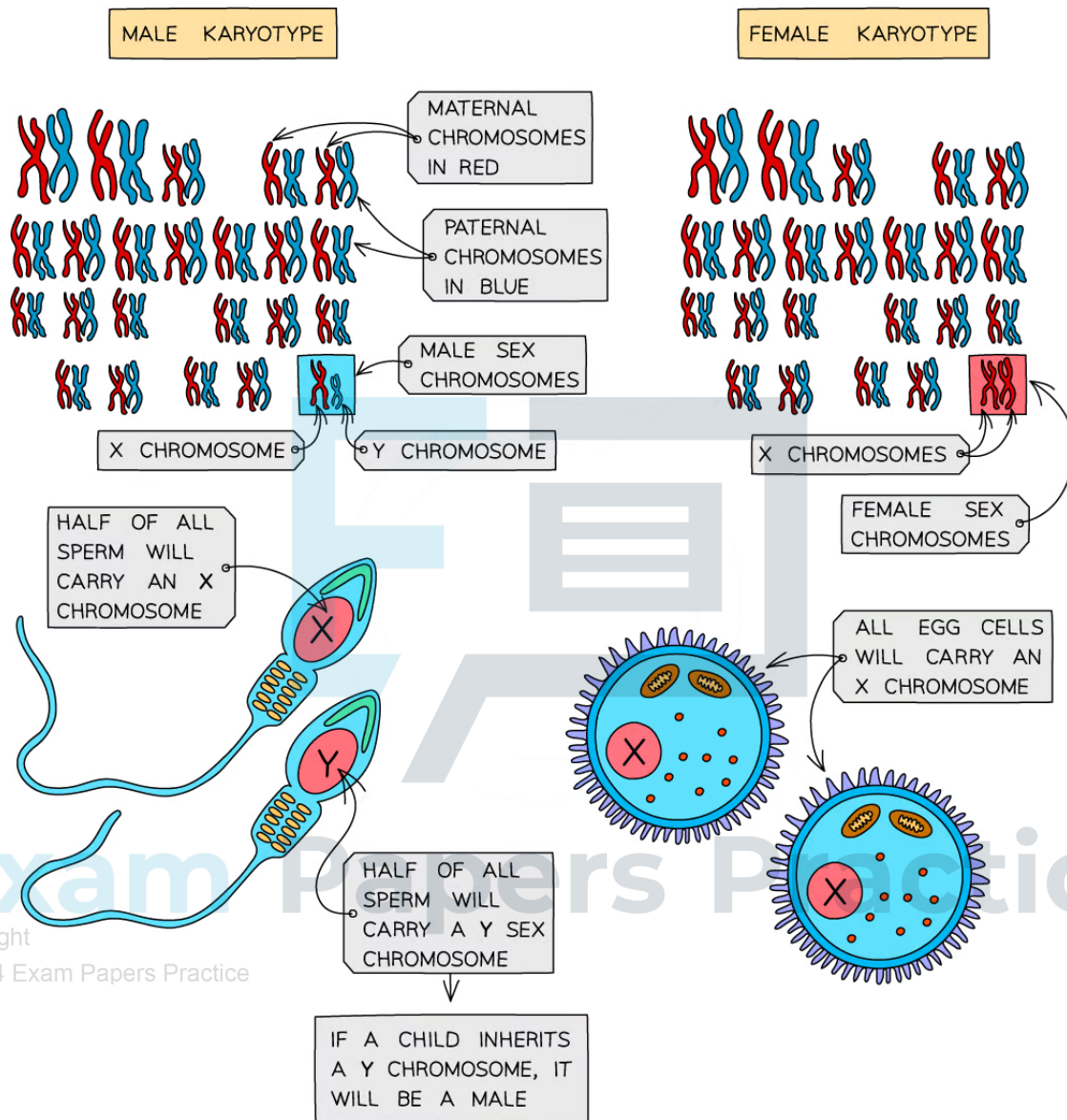

Copyright © 2024 Exam Papers Practice

**Sperm cells determine the sex of offspring**

- The inheritance of sex can be shown using a **genetic diagram** (known as a **Punnett square**), with the X and Y chromosomes taking the place of the alleles usually written in the boxes

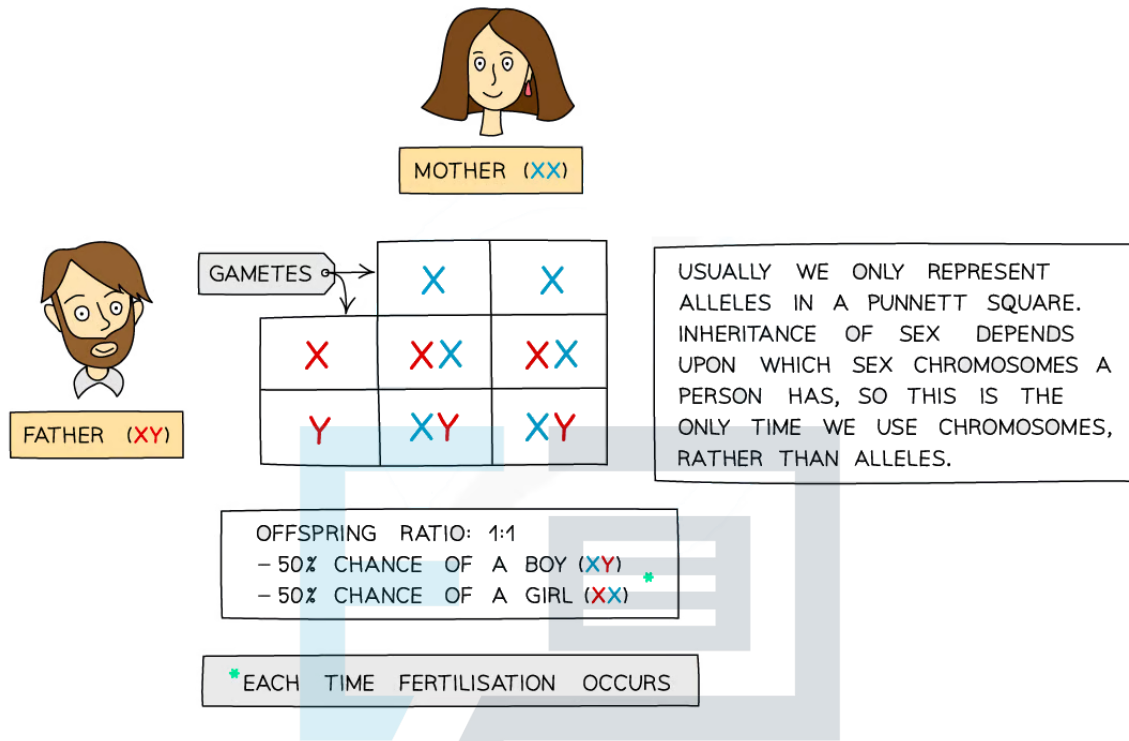

*Punnett square showing the inheritance of sex*

### Genes carried by X and Y chromosomes

Copyright © 2024 Exam Papers Practice. The X chromosome is larger than the Y, and has its centromere more central than on the Y chromosome.

- Fewer genes are coded for on the Y chromosome as a result
  - The X carries around 16 x more genes than the Y chromosome
- Non-sex phenotypic traits, including **certain blood clotting factors**, are coded for on the X chromosome but not on the Y
- The Y chromosome carries genes that **code for male characteristics**
- One of these genes is the **SRY gene** which is involved in
  - Development of testes in male embryos
  - Production of testosterone
- Females don't receive these genes, so instead, **ovaries develop** and **female sex hormones** are expressed

### 3.1.9 Karyograms

#### Karyograms

- During the stages of mitosis, **chromosomes condense** (become visible)
  - This is most notable in **metaphase**
- **Staining** can reveal distinctive banding patterns on chromosomes at this stage
- The **position of the centromere** will also give a clue about which homologous pair a chromosome belongs to
- The process can be frozen in time using **computer image analysis** of all the chromosomes
- Chromosomes can be **placed in their homologous pairs**
- A **karyogram** will show all the chromosomes in homologous pairs, starting with the longest pair and ending with the shortest

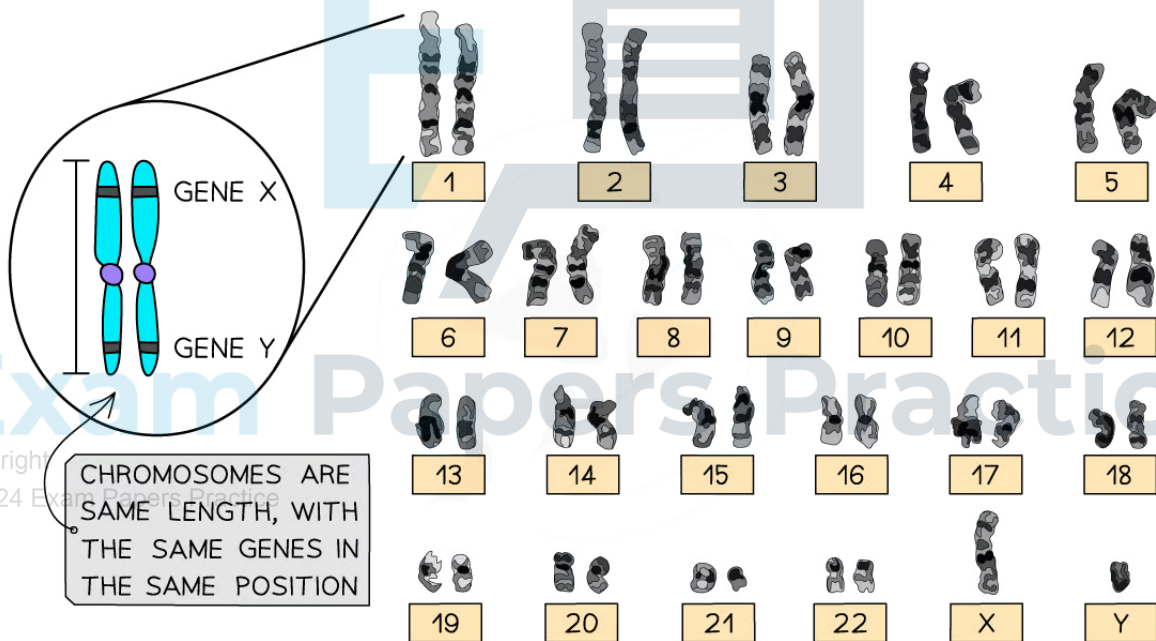

*Human karyogram showing homologous chromosomes. The presence of XY reveals this to be a male.*

## Use of Karyograms

### Use of karyotypes to deduce sex in humans

- Karyograms can be used to examine an individual's **karyotype**
- This can reveal the **sex of an individual** by the appearance of the sex chromosome pair
- A Y chromosome is considerably **shorter** than an X chromosome
  - **XX** chromosomes mean an individual is **female**
  - **XY** chromosomes mean an individual is **male**

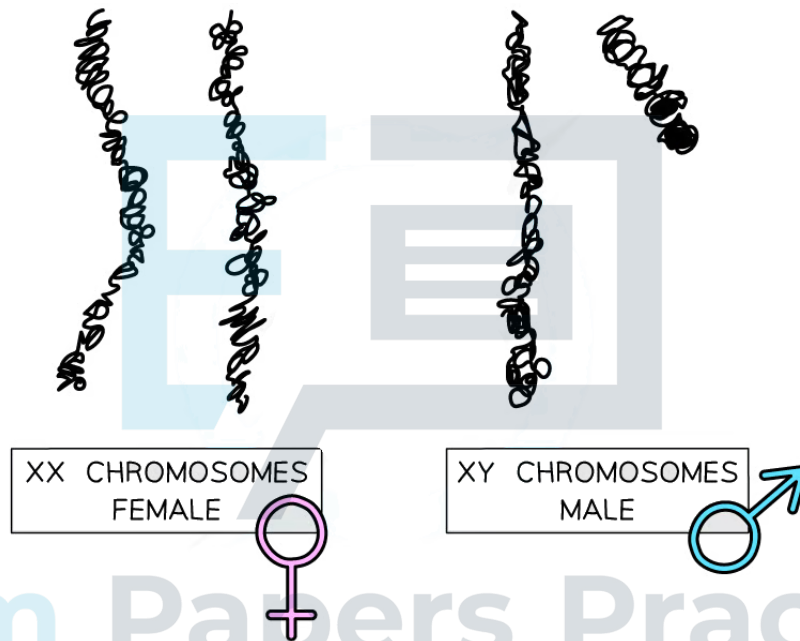

Copyright

© 2024 *Appearance of the XX and XY chromosomes. Note the Y chromosome is much shorter than the X.*

### Use of karyotypes to diagnose Down syndrome in humans

- **Mutations** can occur at different levels, not just mis-copying of individual DNA bases
  - **Chromosome mutations** involve a change in the number of chromosomes
  - A **spontaneous chromosome mutation** called non-disjunction occurs when **chromosomes fail to separate** during meiosis
- The gametes may end up with **one extra copy** of a particular chromosome or no copies of a particular chromosome
- These gametes will have **a different number of chromosomes** compared to the normal haploid number

- Many such gametes will form a non-viable embryo that aborts before becoming a foetus, but not always
- If the abnormal gametes combine in viable fertilization (one that leads to a live birth), then a chromosome mutation occurs as **the diploid cell will have the incorrect number of chromosomes**
- An example of chromosome mutation is **Down syndrome**
- Individuals with Down syndrome have a **total of 47 chromosomes** in their genome as they have three copies of chromosome 21
  - Down syndrome is also called **Trisomy 21**
- **Symptoms** include distinctive facial features, hearing loss, learning and growth impairment

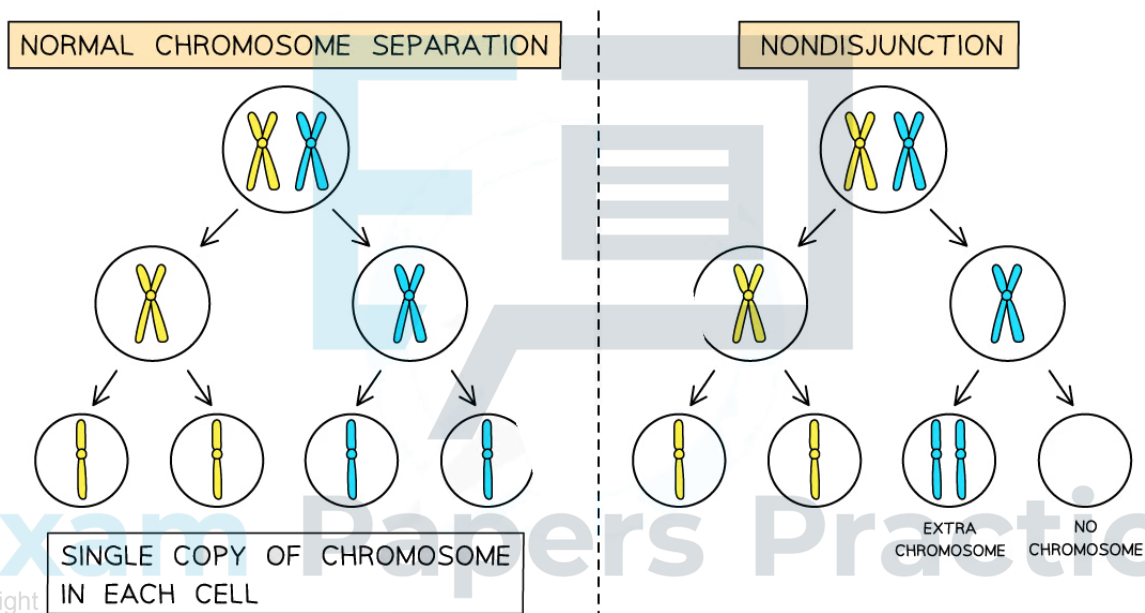

Copyright © 2024 Exam Papers Practice

**Image showing how chromosomes failing to separate properly during meiosis can result in gametes with the incorrect number of chromosomes**



### 3.1.10 Skills: Using Databases

#### Use of Databases to Identify Gene Loci

##### Use of databases to identify the locus of a human gene and its polypeptide product

- Following the **sequencing of the whole human genome**, we now know the **exact locus** (position) of every gene across the 23 pairs of chromosomes
- Online databases have been built that are able to **locate any known gene or allele**
- Anyone can access these loci
  - One example is the **European Molecular Biology Laboratory** database (EMBL)
- Examples of genes that can be located are
  - The **CFTR protein**, critical to **cystic fibrosis**, on chromosome 7
  - **HBB**, a faulty allele of which is the cause of **sickle-cell anaemia**, on chromosome 11
- If we know the locus of a particular gene, medicine can establish **the location of a faulty allele**, which is often recessive
  - A faulty allele can be cut out of the chromosome by genetic engineering using **recombinant DNA technology**
  - Replacing a faulty allele could lead to **genetic therapy**
  - Location databases of **cancer-related genes** are often vital information to researchers, doctors and patients involved in cancer genetics

Exam Papers Practice

Copyright

© 2024 Exam Papers Practice

## Use of Databases: Comparing Base Sequences

Use of a database to determine differences in the base sequence of a gene in two species

- The Genbank® database is another that can be used to **search for DNA base sequences**
  - Uses a computer data analysis technique called BLAST (Basic Local Alignment Search Tool) to spot and 'line up' similar base sequences
- A protein common to all organisms is **cytochrome C**
- This makes its gene sequence a good one **to compare between organisms**
- The sequence is available for many different organisms **across all three domains**
- This gives important information about **evolutionary relationships** between organisms

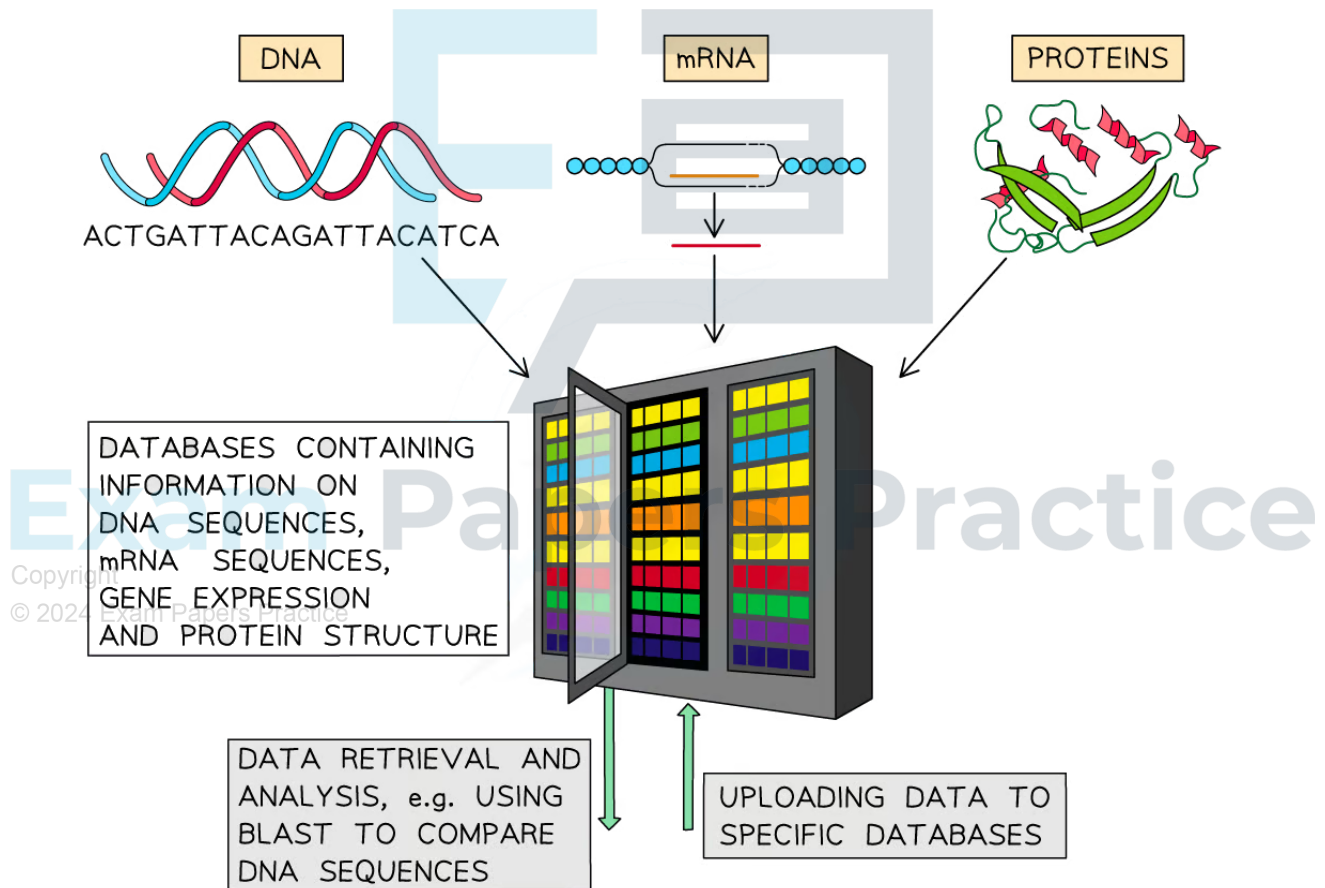

*The use of databases to compare base sequences (and protein sequences) between species*