



Exam Papers Practice

Boost your performance and confidence with these topic-based exam questions

Practice questions created by actual examiners and assessment experts

Detailed mark schemes

Suitable for all boards

Designed to test your ability and thoroughly prepare you

21.1 Spectroscopic Identification of Organic compounds

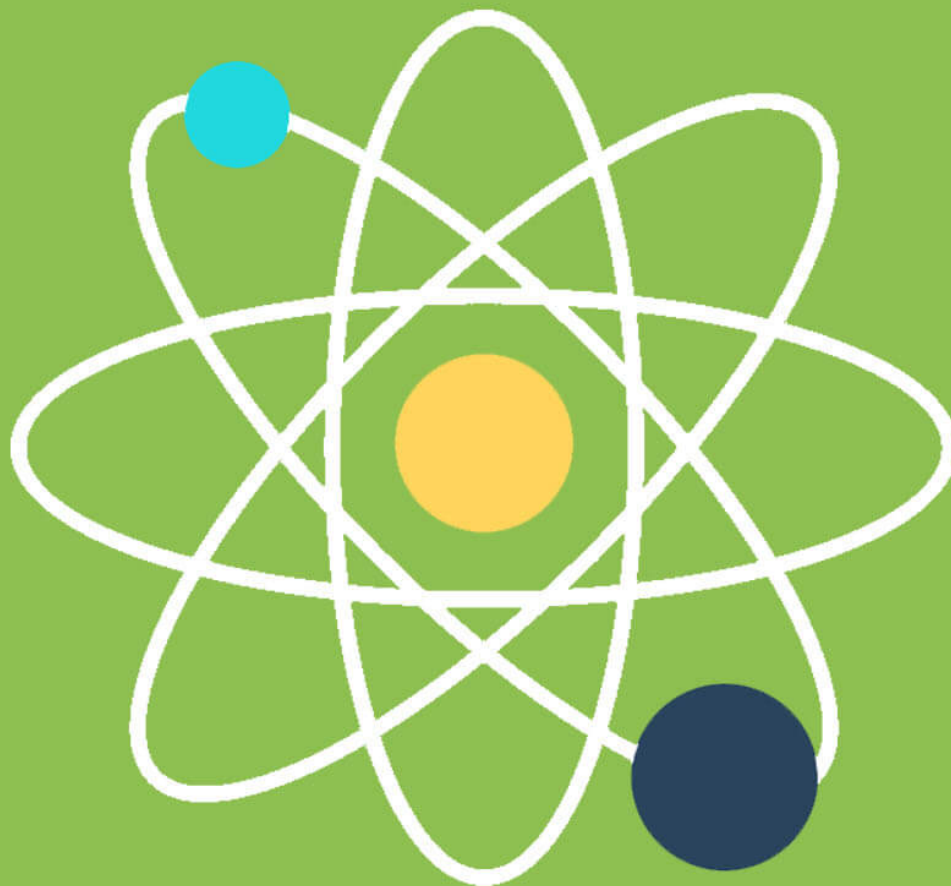

IB Chemistry - Revision Notes

www.exampaperspractice.co.uk



21.1.1 High Resolution NMR

High Resolution NMR

- In the first part of **NMR spectroscopy**, we have seen that the nuclei of H atoms behave as tiny magnets and can interact with an applied magnetic field
- Only atoms with **odd mass numbers** show signals on NMR spectra and have the property of **nuclear spin**

Table showing nuclei which possess spin

Nuclei	Protons	Neutrons	Spin
^1H	1	0	✓
^2H	1	1	X
^{12}C	6	6	X
^{13}C	6	7	✓
^{19}F	9	10	✓
^{31}P	15	16	✓

Copyright

© 2024 Exam Papers Practice

- They can align themselves with the external magnetic field (lower energy state) or against the external field (higher energy state)
- Energy from the radio frequency end of the electromagnetic spectrum can excite the nuclei and cause them to 'flip' between a lower and higher energy state - this is **resonance**
- Samples are irradiated with radio frequency energy while subjected to a strong magnetic field
- Protons on different parts of a molecule (in different molecular environments) absorb and emit (**resonate**) different radio frequencies
- The magnetic field strengths of protons in organic compounds are measured and recorded on a spectrum



- The **resonance energy** is unique to specific H atoms in molecules that are located in the same chemical environment
- Information from the spectrum tells us the number of different H environments
- A reminder about low resolution NMR:

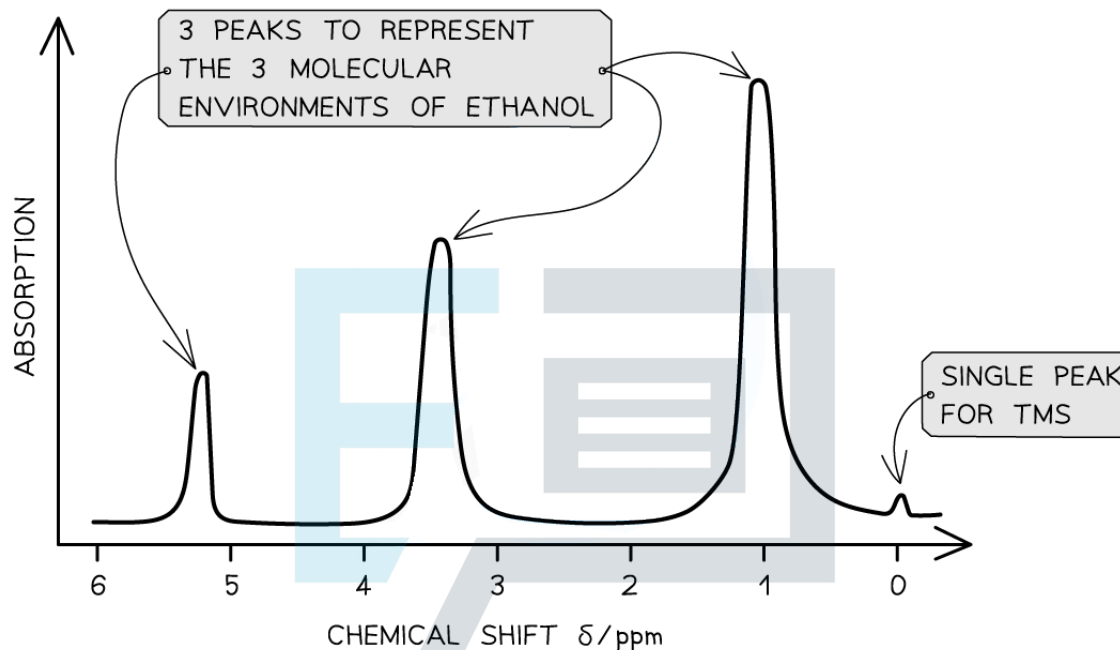

A low resolution ^1H NMR for ethanol showing the key features of a spectrum

Tetramethyl silane

Copyright

© 2024 Exam Papers Practice

- The horizontal scale on an NMR spectrum represents **chemical shift (δ)**
- Chemical shift is measured in parts per million (ppm) of the magnetic field strength needed for resonance in a reference chemical called tetramethylsilane, abbreviated to **TMS**

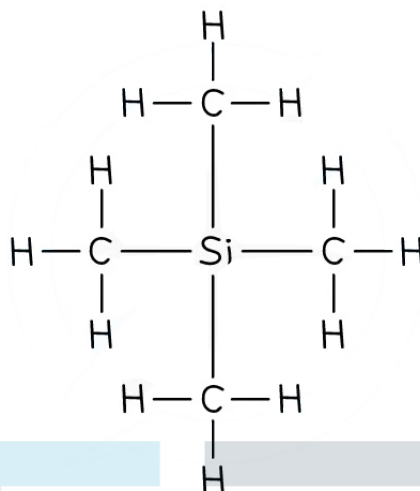

The displayed formula of tetramethylsilane

- TMS is used universally as the reference compound for NMR as its methyl groups are particularly well shielded and so it produces a strong, single peak at the far right of an NMR spectrum
- The signal from the carbon atoms in TMS is defined as having a chemical shift of 0 ppm

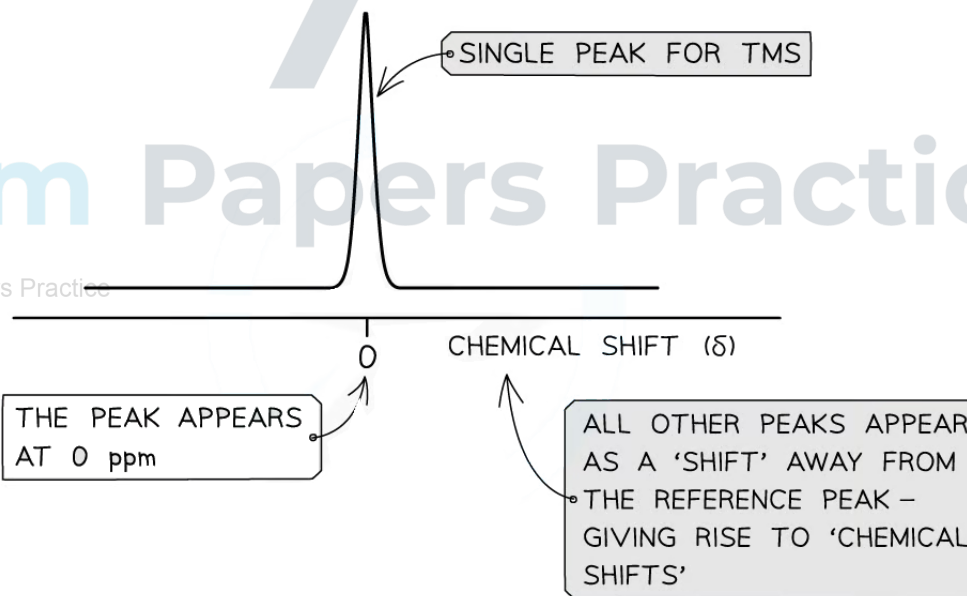

The NMR reference peak for TMS

Copyright

© 2024 Exam Papers Practice

Chemical Shift

- The chemical shift values of peaks on an ^1H NMR spectrum give information about the likely types of proton environment in a compound

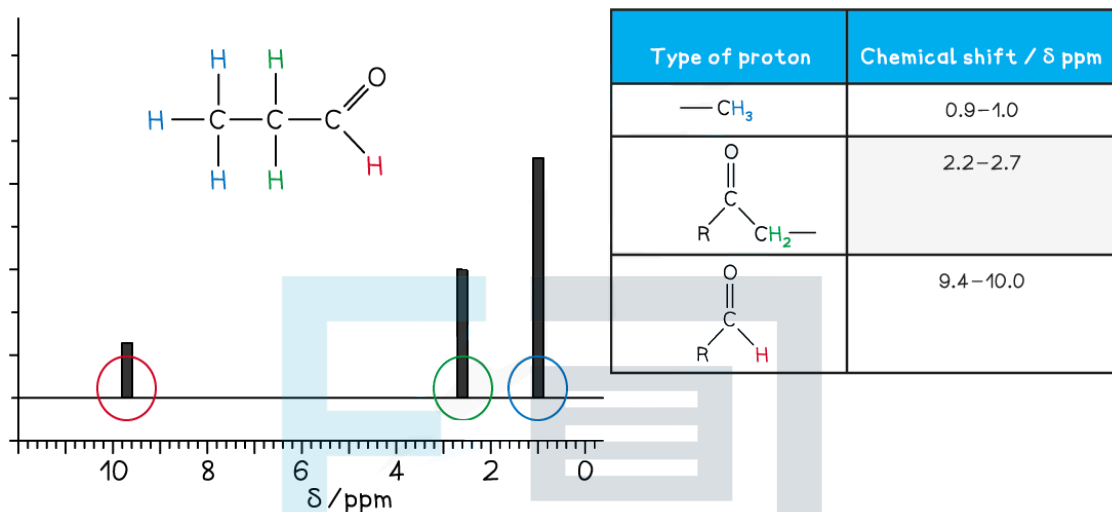

The chemical shift values can be used to identify specific proton environments

Peak Splitting

- High resolution NMR gives more complex signals giving more structural details
- The signals sometimes appear to be split into a number of sub-peaks called doublets, triplets and quartets
 - This is known as **multiplicity**
- The splitting pattern of each peak is determined by the number of protons in neighbouring environments
- The complex signal produced indicates the number of protons on adjacent carbon atoms
- Neighbouring protons produce weak magnetic fields that can interact with each other
- Depending on how that interaction takes place, it allows you to determine the number of neighbouring protons
- Suppose you have a particular view point on an issue
 - You ask your neighbour's opinion
 - Your neighbour could reinforce your argument and make your belief stronger
 - Alternatively, your neighbour could contradict your argument and make it weaker

Copyright

© 2024 Exam Papers Practice

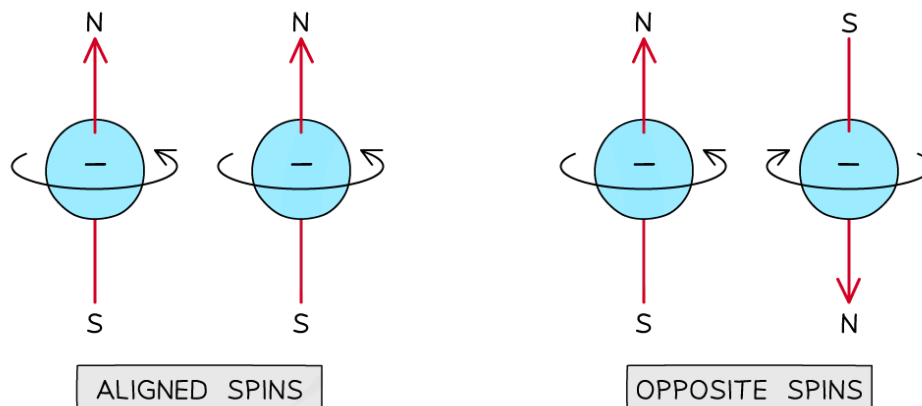

Aligned and opposite spins on neighbouring protons

- If the spin of a neighbouring proton is aligned with the spin of the proton in question, the magnetic field from this spin strengthens the magnetic field
 - The resonance is stronger and results in a slightly higher chemical shift
- The magnetic field from the spin on a neighbouring proton that spins against the first proton weakens the magnetic field
 - The resonance is weaker and results in a slightly lower chemical shift
- The resulting high resolution NMR peak shows a split into a doublet - two equal peaks
- This pattern can only be obtained when there is one neighbouring proton so it gives us useful information about the structure of the molecule
- When there are two neighbouring protons, there are four possible combinations, but two of them have the same outcome on field strength, so three separate peaks are obtained

Table showing the effect of two neighbouring protons on peak splitting

First neighbour	Second neighbour	Field strength	Frequency
+	+	stronger	1
+	-	unchanged	2
-	+	unchanged	
-	-	weaker	1





Copyright

© 2024 Exam Papers Practice



- The resulting peak is split as a triplet
- This is what is seen when a proton is next to a $-CH_2-$ group.
- When there are three neighbouring protons, there are eight possible combinations, four with the same outcome, so four separate peaks are seen, called a quartet
- This is what is seen when a proton is next to a $-CH_3$ group, in other words, a proton that is next to the end of a chain
- The number of split peaks is related to the neighbours following what is termed the **n+1 rule**
 - Where there are n neighbours there are n+1 split peaks

¹H NMR peak splitting patterns table

Number of adjacent protons (n)	Splitting pattern using the n+1 rule the peak will split into...	Relative intensities in splitting pattern	Shape
0	1, singlet	1	
1	2, doublet	1 : 1	
2	3, triplet	1 : 2 : 1	
3	4, quartet	1 : 3 : 3 : 1	

Exam Papers Practice
Copyright © 2024 Exam Papers Practice



- In summary, an NMR spectrum provides several types of information
 - number of **signal groups**... ..the number of **different proton environments**
 - **chemical shift**... ..the **general environment** of the protons
 - **peak area**... ..the **relative number of protons** in each environment
 - **multiplicity**... ..how many **protons** are on **adjacent atoms**
- In many cases, this information is sufficient to deduce the structure of an organic molecule but other forms of spectroscopy are used in conjunction with NMR to confirm structural information

21.1.2 X-Ray Crystallography

X-Ray Crystallography

- When visible light waves interact with objects the light is scattered, transmitted and reflected – this gives us information about the macroscopic world
- However, at the scale of atoms, the wavelength of visible light (380–700 nm) is far too large to interact with atoms and molecules in this way
- Inter-atomic distances are in the order of 10^{-9} m (1nm) which corresponds to the wavelength of X-rays
- The structural technique of single crystal X-ray crystallography can be used to identify the bond lengths and bond angles of crystalline compounds

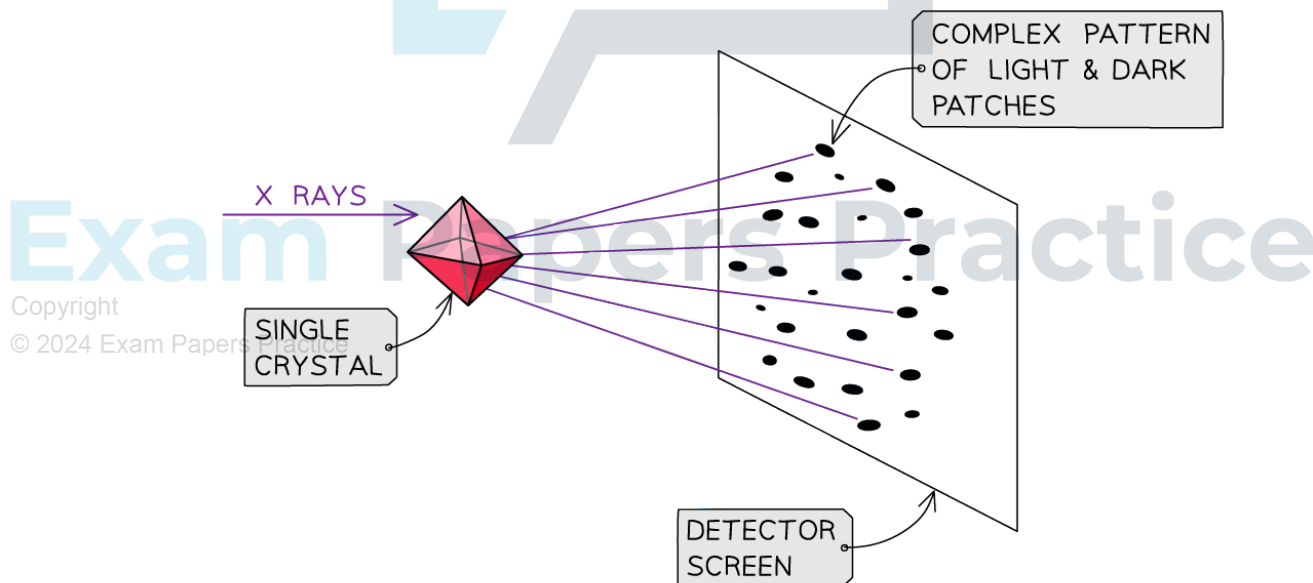

The technique of X-ray crystallography forms diffraction patterns which allow the structure of crystals to be deduced

- As X-rays pass through the different layers of a crystal they are refracted and reflected in consecutive planes
- The scattered waves interfere and are at different phases when they hit the detector
- The result is a complex pattern at the detector which can be interpreted to give regions of high and low electron density corresponding to the location of atoms within the crystal structure

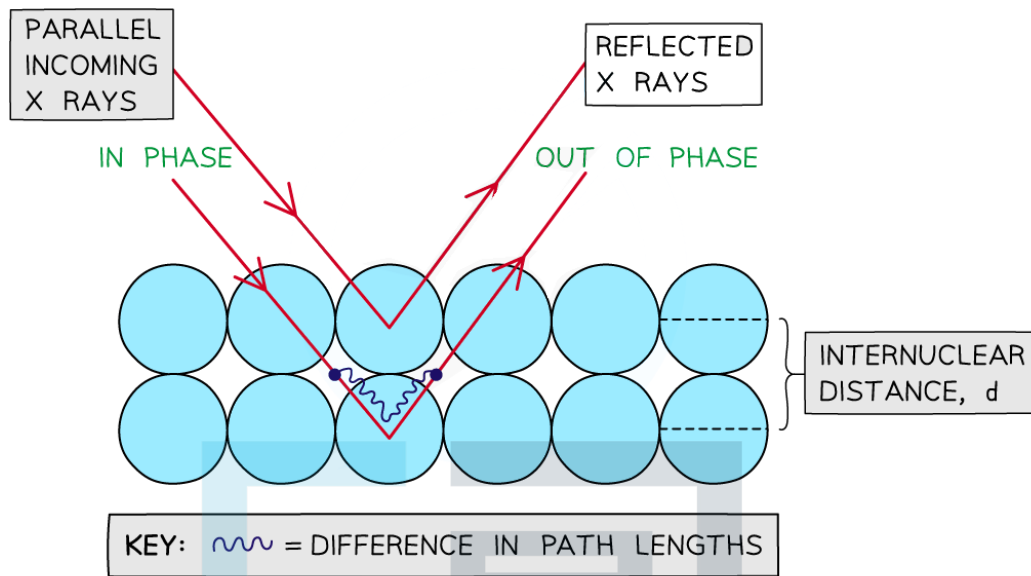

X-ray Scattering

Constructive and destructive interference

- Constructive interference occurs when two waves are in phase with the peaks aligned
- The result is the waves reinforce each other creating a wave with larger amplitude:

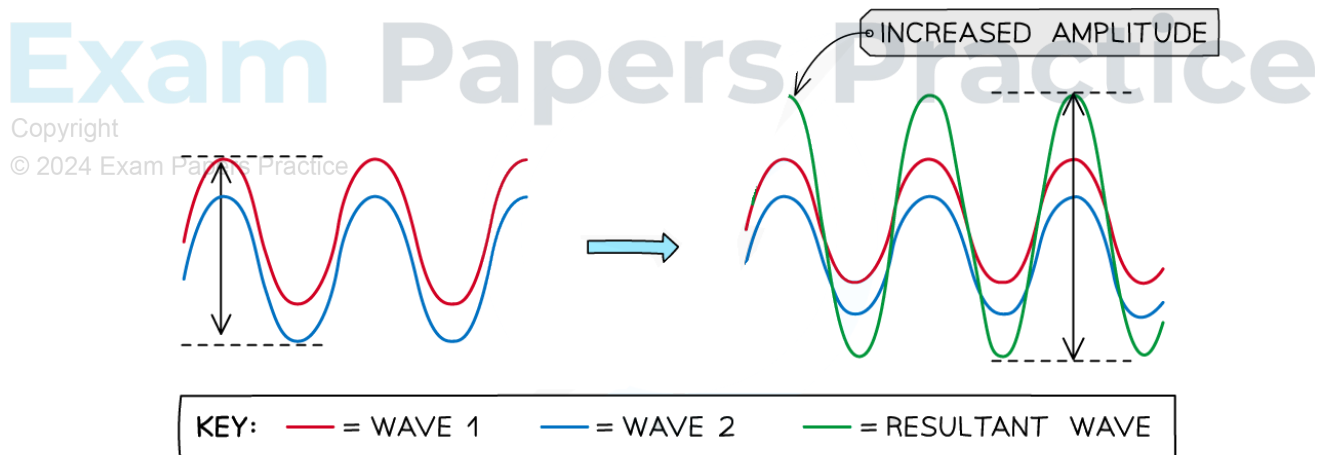

Constructive interference of waves

- Destructive interference occurs when two waves are out of phase by 180° with one peak aligned with the trough of another
- The result is the waves cancel each other out
- If they have the same amplitude, it is complete cancelling and is called complete destructive interference

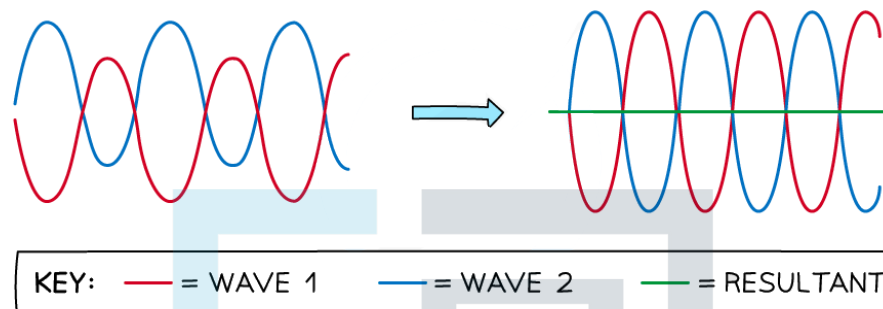

Destructive interference of waves

- The diffraction pattern obtained depends on the complex relationship between the angle of incidence, the wavelength and the distance and orientation between the atoms
- A map of electron density can be determined from the diffraction pattern, just as the weave of a fabric can be determined by holding the fabric up to the light
- Early uses of X-ray crystallography were to study the structure of ionic solids, such as sodium chloride
- Contour lines connect points of equal density and show regions where electron density is highest

Copyright

© 2024 Exam Papers Practice

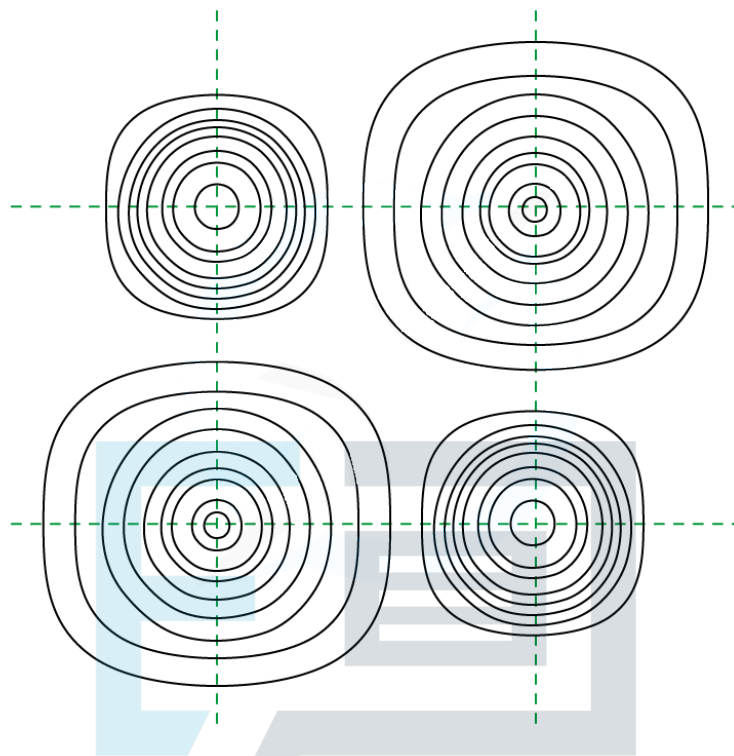

*An electron density contour map for sodium chloride showing the position of sodium and chloride ions.
The larger ions are the chloride ions.*

Exam Papers Practice

- X-ray crystallography can be applied to organic compounds which are able to form solid crystalline structures
- Copyright © 2024 Hydrogen atoms have very low electron density so they barely show up in electron density maps, but the position of other atoms is evident and can be used to measure internuclear distance and bond angle



An electron density map for naphthalene showing the location of the carbon atoms in two adjoining hexagonal rings

- The structure of complex biological molecules such as DNA has been determined by X-ray crystallography

Exam Papers Practice

Copyright

© 2024 Exam Papers Practice



21.1.3 Structure Identification Problems

Structure Identification Problems

- The chemists' toolkit includes a range of analytical techniques that enable the structure of compounds to be deduced

Summary table of analytical techniques

Technique	Information provided
Mass spectrometry	Relative atomic mass. Isotopes. Relative molecular mass. Fragments in organic compounds. Structure of organic compounds
Nuclear magnetic spectroscopy	Structure of organic compounds
Infrared spectroscopy	Types of covalent bonds. Functional groups
X-ray crystallography	Structure of crystalline solids. Bond lengths and bond angles. Atomic radius, ionic radius & covalent radius

Copyright

© 2024 Exam Papers Practice

- These techniques are rarely used in isolation, but together provide corroborating evidence for elucidating chemical information on newly discovered or synthetic compounds
- Problem solving typically involves taking multiple pieces of spectroscopic data about the same unknown compound and coming up with a likely structure

 **Worked example**

An unknown compound, X, of molecular formula, C_4H_8O , has the following MS, IR and 1H NMR spectra.

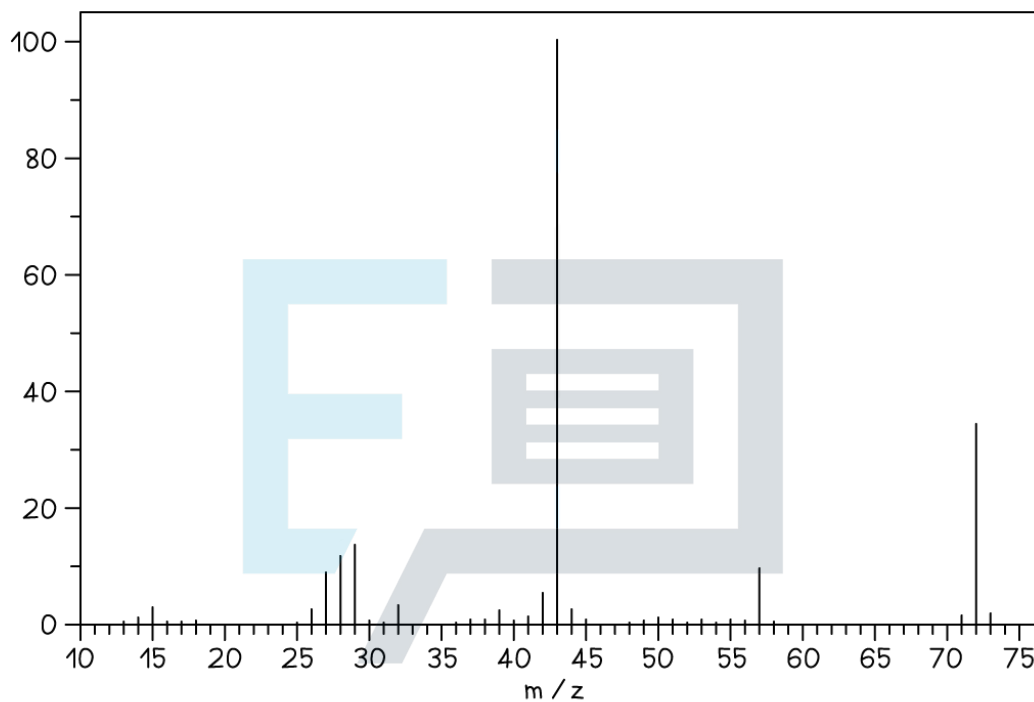

Exam Papers Practice

Copyright

© 2024 Exam Papers Practice

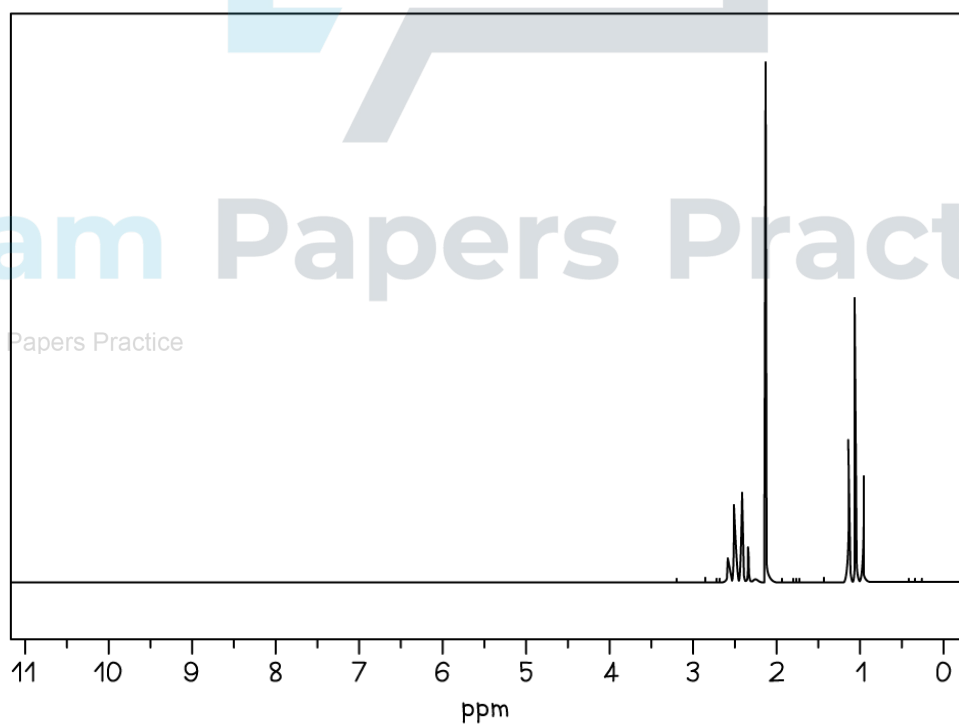
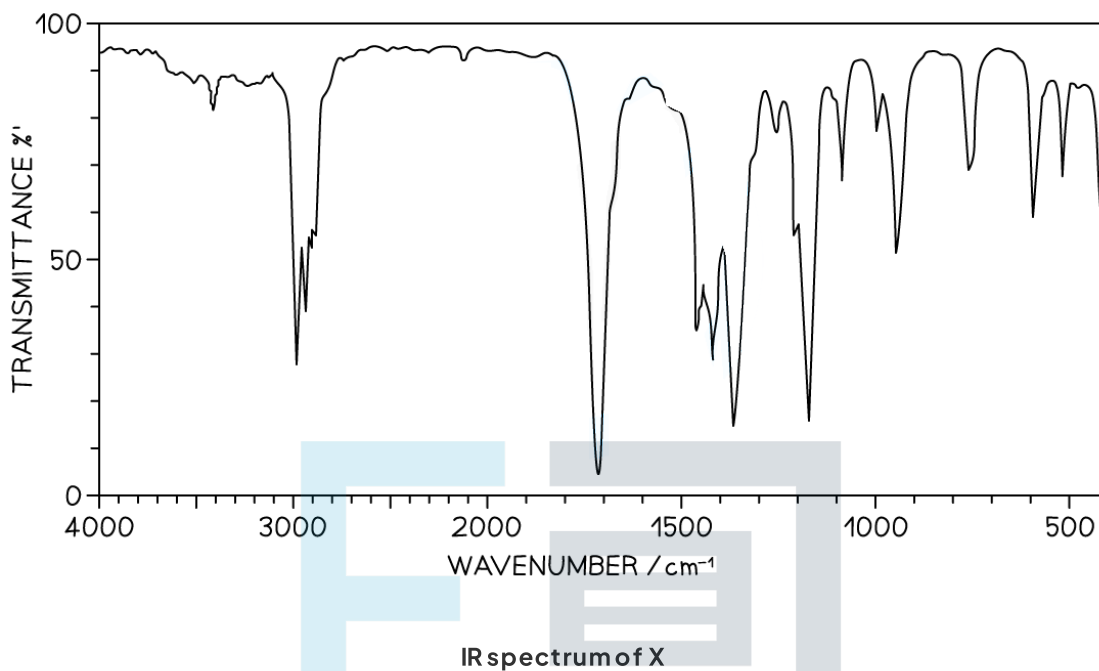

Copyright
© 2024 Exam Papers Practice

¹H NMR spectrum of X

Deduce the structure of X using the information given and any other additional information in the Data booklet. For each spectrum assign as much spectroscopic information as possible.

Answer

Mass Spectrum

- The molecular ion peak is at $m/z = 72$, which corresponds to the relative molecular mass of C_4H_8O

$$M_r = (12 \times 4) + (8 \times 1) + (16) = 72$$

- The large peak at $m/z = 43$ could correspond to $CH_3CH_2CH_2^+$ or CH_3CO^+ indicating the loss of CH_4O or C_2H_5 from X, that is ($M_r - 43$)
- The peak at $m/z = 29$ could correspond to $CH_3CH_2^+$ indicating the loss of C_2H_3O from X, that is ($M_r - 29$)

IR Spectrum

- There is a strong absorption in the range $1700 - 1750 \text{ cm}^{-1}$ which corresponds to $C=O$, based on Section 26 of the Data book
- This suggests an aldehyde or ketone is present (it cannot be an ester or carboxylic acid as only one oxygen is in the formula)

¹H NMR Spectrum

- The ¹H NMR spectrum shows three proton environments
- The peak around chemical shift 1.0 ppm could correspond to a proton on the end of a chain, - CH_3
- The peaks around chemical shift 2.2 - 2.7 ppm could correspond to a proton next to a carbonyl group RCH_2CO-
- The peak splitting is a quartet, singlet and triplet
- A quartet and triplet in the same spectrum usually corresponds to an ethyl group, CH_3CH_2 , following the $n+1$ rule
- The singlet indicates an isolated proton environment

Putting the information together the structure of X is

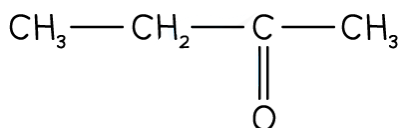

The structure of X is butanone