

Centre Number						Candidate Number				
Surname										
Other Names										
Candidate Signature										

For Examiner's Use	
Examiner's Initials	
Question	Mark
1	
2	
3	
4	
5	
6	
7	
8	
TOTAL	



General Certificate of Secondary Education
Higher Tier
June 2015

Physics

Unit Physics P3

PH3HP

H

Wednesday 20 May 2015 1.30 pm to 2.30 pm

For this paper you must have:

- a ruler
- a calculator
- the Physics Equations Sheet (enclosed).

Time allowed

- 1 hour

Instructions

- Use black ink or black ball-point pen.
- Fill in the boxes at the top of this page.
- Answer **all** questions.
- You must answer the questions in the spaces provided. Do not write outside the box around each page or on blank pages.
- Do all rough work in this book. Cross through any work you do not want to be marked.

Information

- The marks for questions are shown in brackets.
- The maximum mark for this paper is 60.
- You are expected to use a calculator where appropriate.
- You are reminded of the need for good English and clear presentation in your answers.
- Question 3(b) should be answered in continuous prose.
In this question you will be marked on your ability to:
 - use good English
 - organise information clearly
 - use specialist vocabulary where appropriate.

Advice

- In all calculations, show clearly how you work out your answer.



J U N 1 5 P H 3 H P 0 1

There are no questions printed on this page

**DO NOT WRITE ON THIS PAGE
ANSWER IN THE SPACES PROVIDED**



Answer **all** questions in the spaces provided.

- 1** The clock shown in **Figure 1** uses a pendulum to keep time.

Figure 1

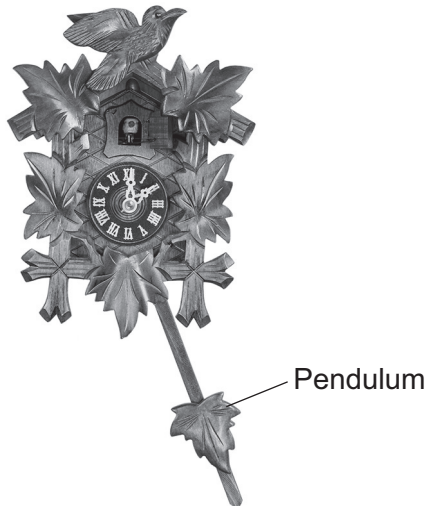

- 1 (a)** The pendulum has a frequency of 0.80 Hz.
Calculate the periodic time of the pendulum.
Use the correct equation from the Physics Equations Sheet.

[2 marks]

.....
.....
.....

Periodic time = seconds

Question 1 continues on the next page

Turn over ►



- 1 (b) A student investigated the factors affecting the oscillation of a pendulum. The student set up a pendulum as shown in **Figure 2**.

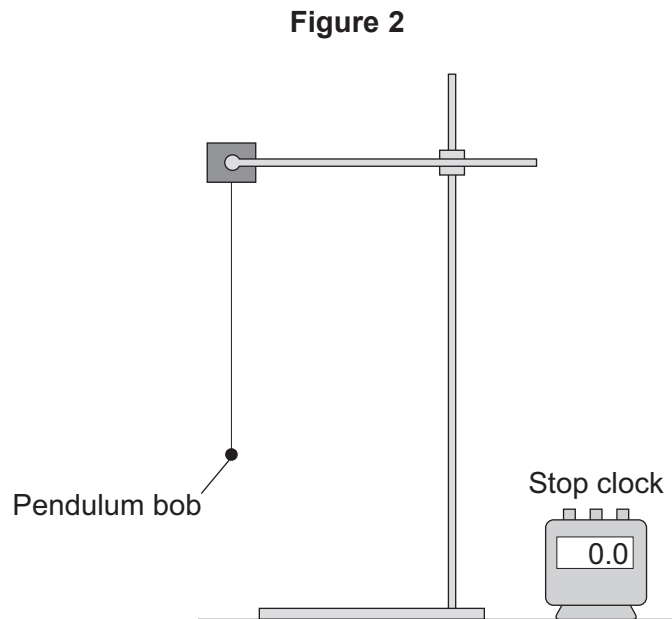

The student investigated how many complete oscillations the pendulum made for different lengths of the pendulum and different masses of the pendulum bob.

The results are shown in **Table 1**.

Table 1

Length of the pendulum in millimetres	Mass of the pendulum bob in grams	Number of complete oscillations made by the pendulum in 20 seconds
200	100	22
200	200	22
400	100	15
400	200	15
600	50	13
600	100	13



1 (b) (i) State **two** conclusions that the student should make from the results shown in **Table 1**.
[2 marks]

1

.....

2

.....

1 (b) (ii) The student wants to be more certain that her conclusions are correct.

Suggest **two** ways in which the investigation could be improved.

[2 marks]

1

.....

2

.....

6

Turn over for the next question

Turn over ►



- 2 (a) **Figure 3** shows a car travelling around a bend in the road. The car is travelling at a constant speed.

Figure 3

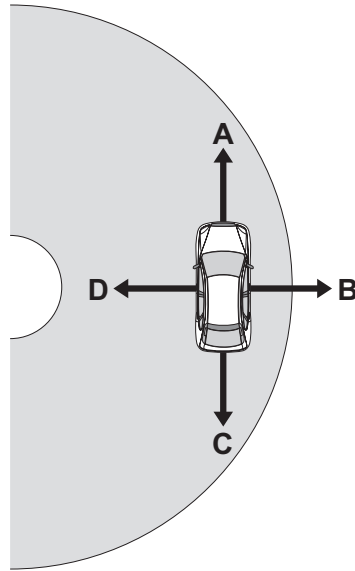

There is a resultant force acting on the car. This resultant force is called the centripetal force.

- 2 (a) (i) In which direction, **A**, **B**, **C** or **D**, does the centripetal force act on the car?

[1 mark]

Tick (✓) **one** box.

A B C D

- 2 (a) (ii) State the name of the force that provides the centripetal force.

[1 mark]

.....



2 (a) (iii) State **two** factors that affect the size of the centripetal force acting on the car.

[2 marks]

1

2

2 (b) **Figure 4** shows a racing car.

Figure 4



The racing car should not roll over when racing.

State **two** features of the car that make it difficult for the car to roll over.

[2 marks]

1

.....

2

.....

6

Turn over for the next question

Turn over ▶



3 (a) Complete the following sentences.

[2 marks]

Ultrasound waves have a minimum frequency of hertz.

The wavelength of an X-ray is about the same as the diameter of

3 (b) In this question you will be assessed on using good English, organising information clearly and using specialist terms where appropriate.

Figure 5 shows one medical use of ultrasound and one medical use of X-rays.

Figure 5



Compare the medical uses of ultrasound and X-rays.

Your answer should include the risks, if any, and precautions, if any, associated with the use of ultrasound and X-rays.

[6 marks]

.....
.....
.....
.....
.....
.....
.....
.....
.....



.....

.....

.....

.....

Extra space

.....

.....

.....

.....

.....

.....

.....

.....

.....

.....

8

Turn over for the next question

Turn over ►



4 (a) Figure 6 shows a diagram of a human eye.

Figure 6

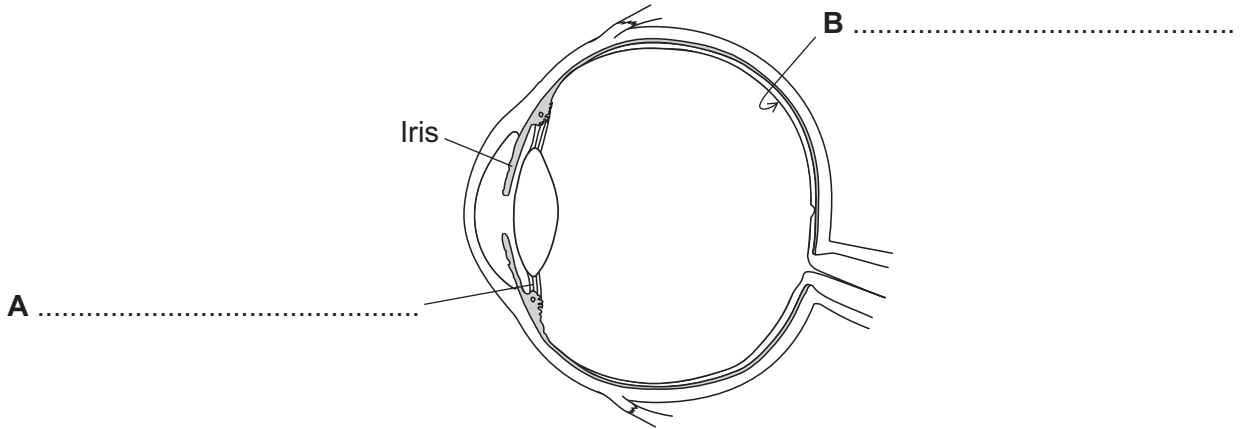

Label the parts **A** and **B** on **Figure 6**.

[2 marks]

4 (b) State the function of the iris.

[1 mark]

.....

.....

4 (c) Figure 7 shows light rays travelling into the human eye.

Figure 7

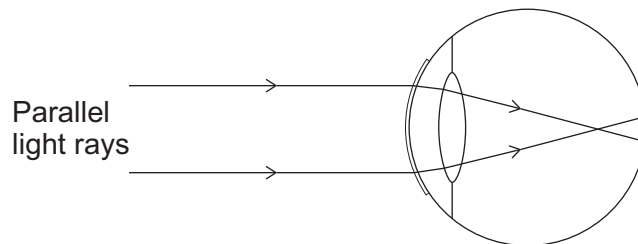

4 (c) (i) Give the name of the defect of vision shown in **Figure 7**.

[1 mark]

.....



- 4 (c) (ii) A concave (diverging) lens can be used to correct the defect of vision shown in **Figure 7**.

Complete the ray diagram in **Figure 8** to show how a concave lens produces an image of the object.

Use an arrow to represent the image.

[3 marks]

Figure 8

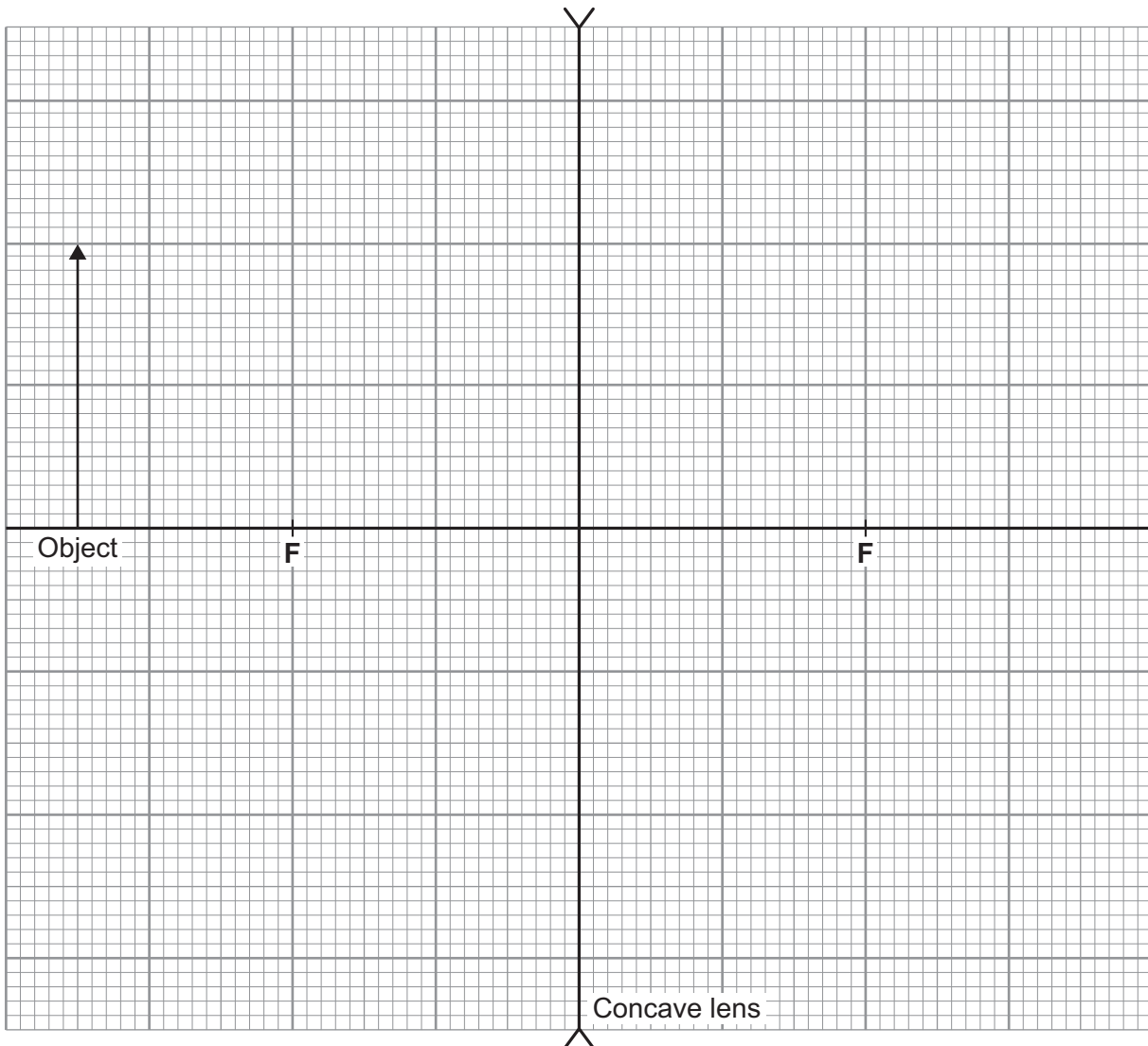

- 4 (d) It is important that muscles can change the power of the lens in the eye.
State why.

[1 mark]

.....

Turn over ►



4 (e) The 'power range' of an eye lens is the difference between the maximum and minimum power of the lens.

Figure 9 shows how the power range of an eye lens changes with age.

Figure 9

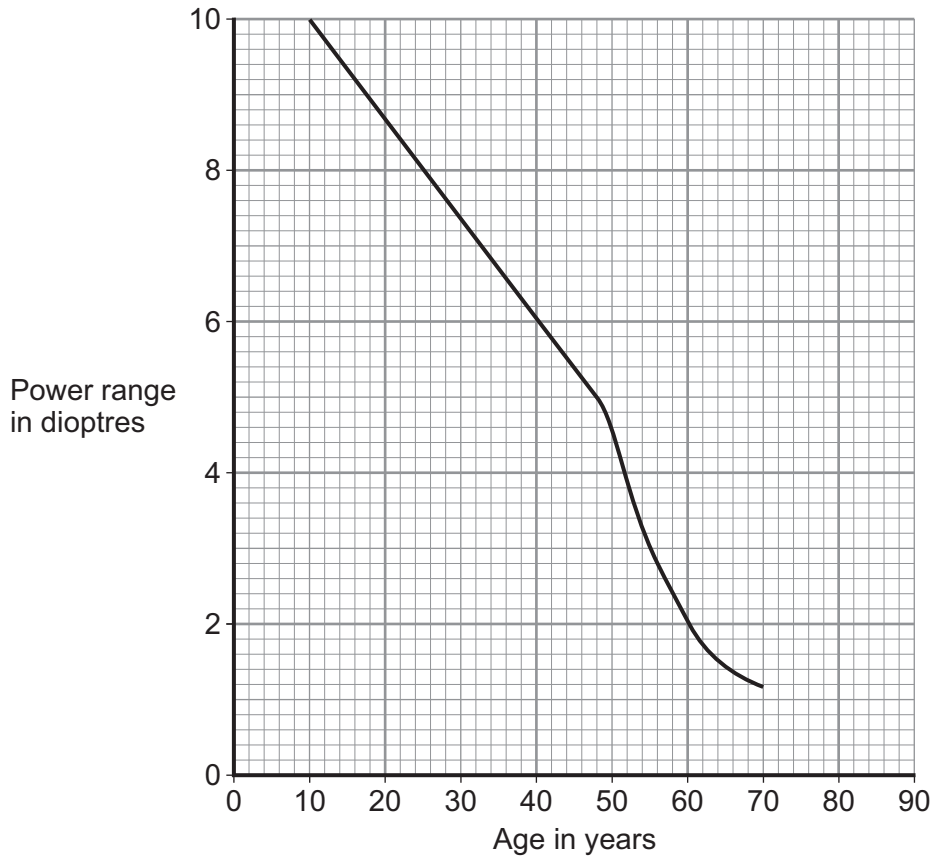

4 (e) (i) Use data from **Figure 9** to calculate the maximum change that can happen to the **focal length** of the eye lens for a 60-year-old person.

Use the correct equation from the Physics Equations Sheet.

Give the unit.

[2 marks]

.....

.....

.....

Maximum change in focal length = unit



4 (e) (ii) Compare the change in power range of the eye lens between the ages of 10 and 30 with that between the ages of 50 and 70.

[3 marks]

.....

.....

.....

.....

.....

.....

4 (e) (iii) Use **Figure 9** to suggest the power range of the eye lens for a 90-year-old person.

[1 mark]

Power range = dioptries

14

Turn over for the next question

Turn over ►



5 **Figure 10** shows apparatus set up by a student.

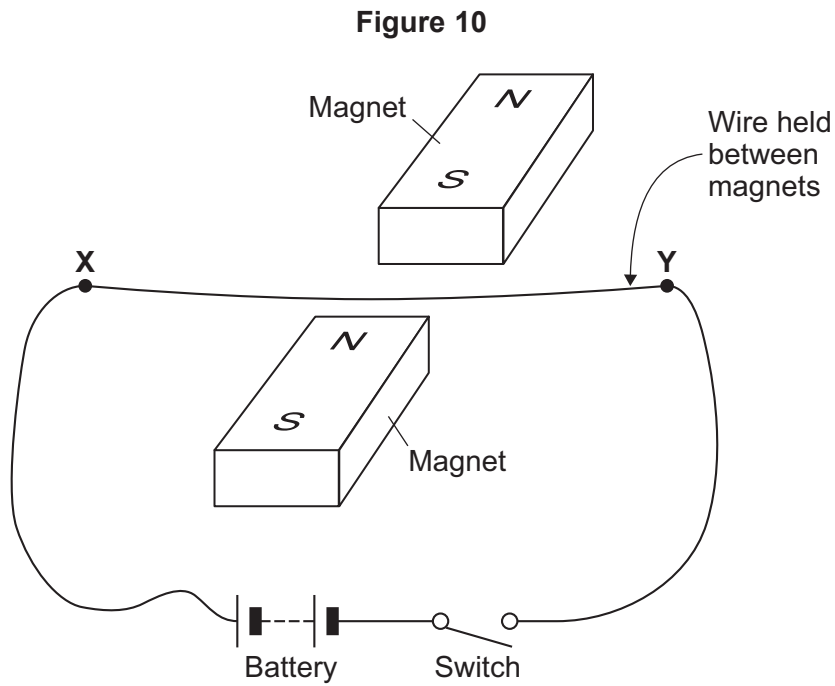

Closing the switch creates a force that acts on the wire **XY**.

5 (a) (i) Explain why a force acts on the wire **XY** when the switch is closed.

[3 marks]

.....

.....

.....

.....

.....

.....

.....

5 (a) (ii) The force causes the wire **XY** to move.
Draw an arrow on **Figure 10** to show the direction in which the wire **XY** will move.

[1 mark]

5 (a) (iii) State the effect that this experiment demonstrates.

[1 mark]

.....



5 (b) The student replaced the battery with a low frequency alternating current (a.c.) power supply.

The student closed the switch.

5 (b) (i) Describe the movement of the wire.

[1 mark]

.....

5 (b) (ii) Give a reason for your answer to part (b)(i).

[1 mark]

.....
.....
.....

7

Turn over for the next question

Turn over ►



6 **Figure 11** shows a ray of light travelling through a semicircular glass block. The angle of incidence is labelled i .

Figure 11

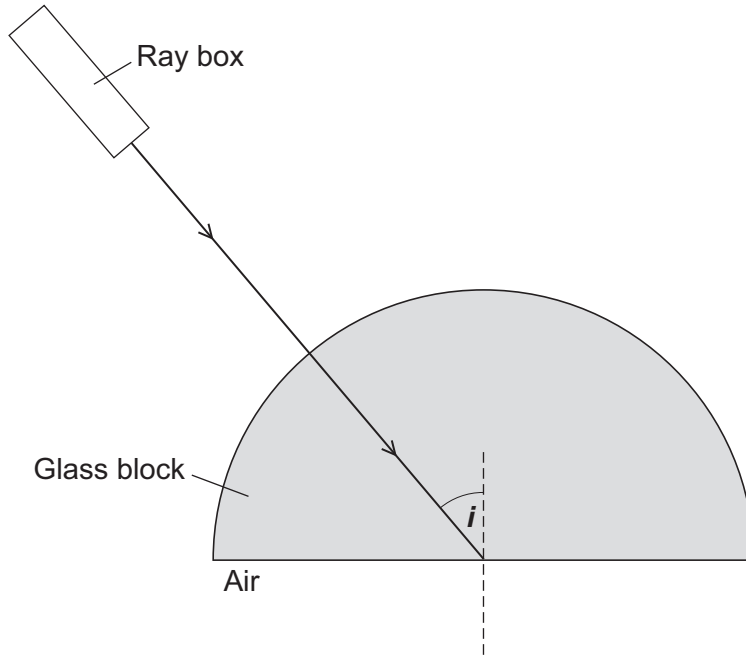

6 (a) (i) The angle of incidence i equals the critical angle for the glass.

Complete **Figure 11** to show what happens to the ray of light at the glass-to-air boundary.

[1 mark]

6 (a) (ii) The critical angle for the glass is 41° .

Calculate the refractive index of the glass.

Use the correct equation from the Physics Equations Sheet.

[2 marks]

.....

.....

.....

Refractive index =



6 (b) **Figure 12** shows what happens to a ray of light as it meets the boundary between air and water.

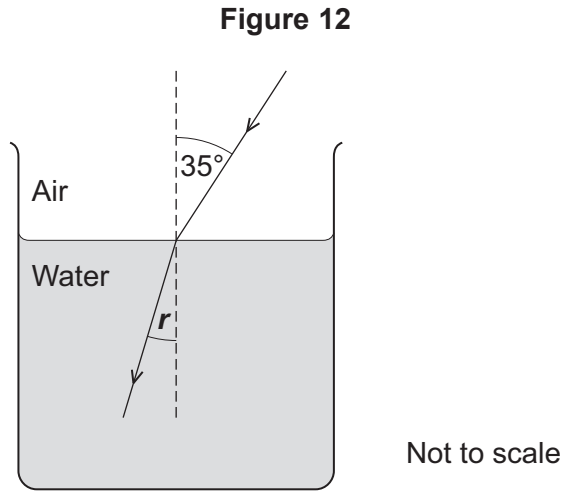

The refractive index of the water is 1.3

Calculate the angle of refraction r .

Use the correct equation from the Physics Equations Sheet.

[3 marks]

.....

.....

.....

.....

.....

Angle of refraction = degrees

6

Turn over for the next question

Turn over ►



7 Before a new bus can be used on the roads, it must pass a stability test. **Figure 13** shows how the bus is tested.

Figure 13

Front view

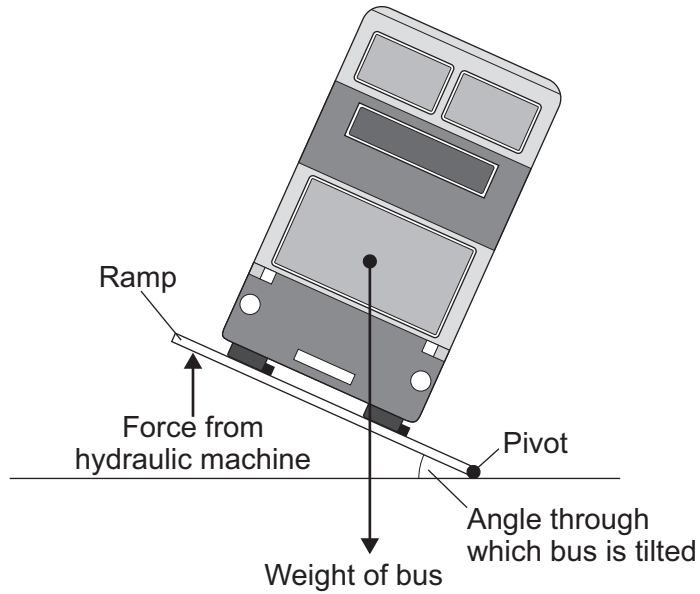

7 (a) (i) The bus will topple over if the ramp is tilted at too great an angle.

Explain why.

[2 marks]

.....

.....

.....

.....

7 (a) (ii) The bus is tested to angles of tilt far greater than it would experience in normal use.

Suggest **two** reasons why.

[2 marks]

1

.....

2

.....



7 (b) Figure 14 shows the hydraulic machine that is used to make the ramp tilt.

Figure 14

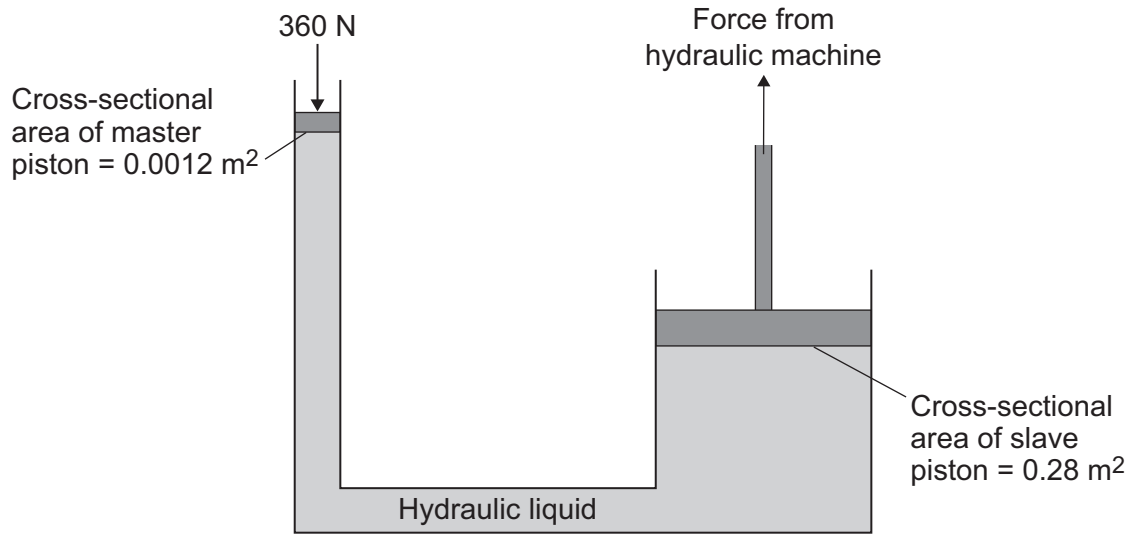

The pressure applied to the hydraulic liquid at the master piston is the same as the pressure applied by the hydraulic liquid to the slave piston.

7 (b) (i) State the property of the liquid that keeps the pressure at both pistons the same.

[1 mark]

.....

7 (b) (ii) A 360 N force acts on the master piston.

Use information from Figure 14 to calculate the force applied by the hydraulic liquid to the slave piston.

Use the correct equation from the Physics Equations Sheet.

[3 marks]

.....

Force = N



- 8 An electric toothbrush is charged by standing it on a separate charging base. **Figure 15** shows the inside of the electric toothbrush and the charging base.

Figure 15

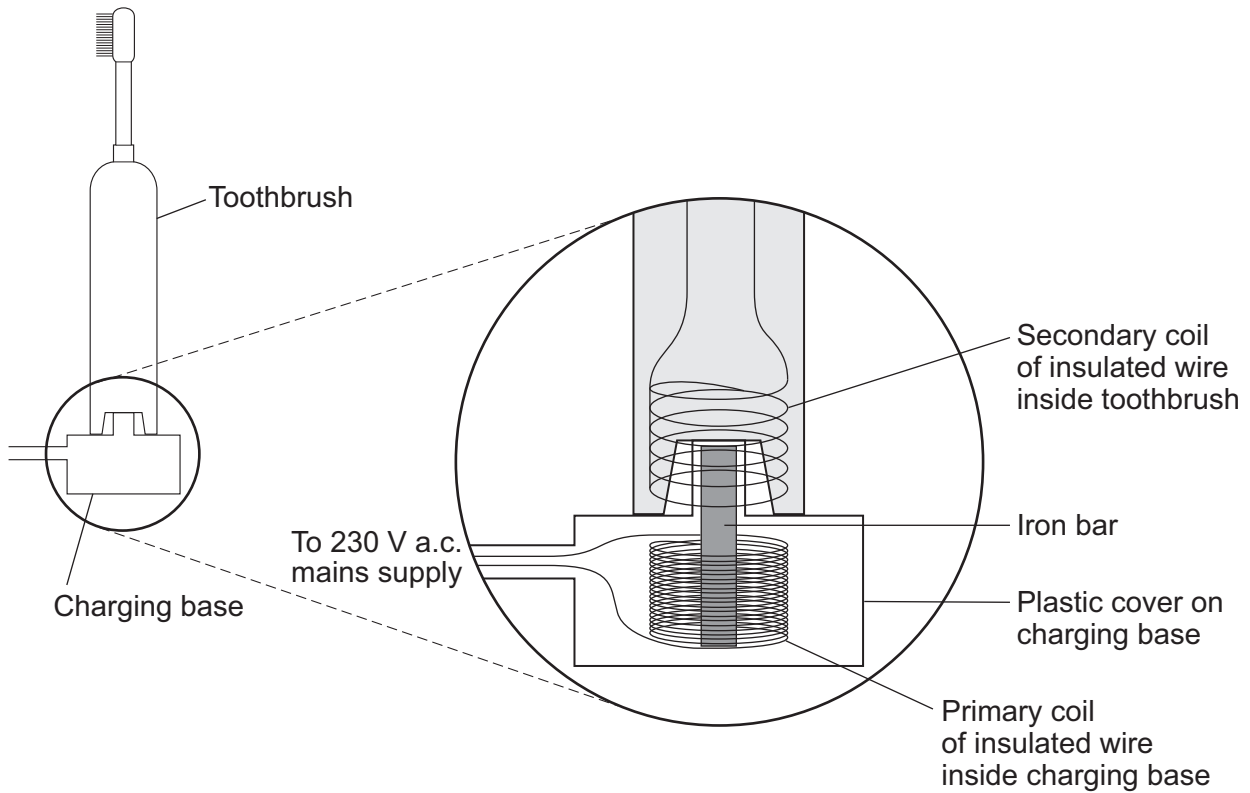

- 8 (a) An alternating potential difference (p.d.) across the coil in the charging base creates an alternating current in the coil inside the toothbrush.

Explain how.

[3 marks]

.....

.....

.....

.....

.....

.....

.....

.....

.....



8 (b) When the toothbrush is being charged, the p.d. across the primary coil in the charging base is 230 V.

The charging p.d. across the secondary coil in the toothbrush is 7.2 V.

The primary coil in the charging base has 575 turns of wire on its coil.

Calculate the number of turns on the secondary coil inside the toothbrush.

Use the correct equation from the Physics Equations Sheet.

[2 marks]

.....
.....
.....
.....

Number of turns on the secondary coil =

5

END OF QUESTIONS



There are no questions printed on this page

**DO NOT WRITE ON THIS PAGE
ANSWER IN THE SPACES PROVIDED**



There are no questions printed on this page

**DO NOT WRITE ON THIS PAGE
ANSWER IN THE SPACES PROVIDED**



There are no questions printed on this page

**DO NOT WRITE ON THIS PAGE
ANSWER IN THE SPACES PROVIDED**

Acknowledgement of copyright-holders and publishers

Permission to reproduce all copyright material has been applied for. In some cases, efforts to contact copyright-holders have been unsuccessful and AQA will be happy to rectify any omissions of acknowledgements in future papers if notified.

Question 1 Figure 1: © Thinkstock

Question 2 Figure 4: © Getty Images/Mark Evans

Question 3 Figure 5: left © Thinkstock/Monkeybusiness Images

Question 3 Figure 5: right © Getty Images/Phil Boorman

Copyright © 2015 AQA and its licensors. All rights reserved.

