

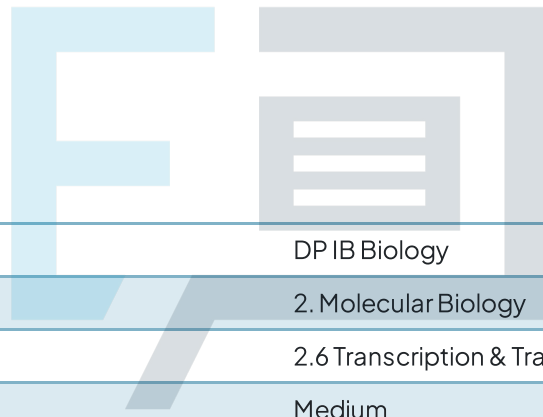

2.6 Transcription & Translation

Question Paper



Course	DP IB Biology
Section	2. Molecular Biology
Topic	2.6 Transcription & Translation
Difficulty	Medium

Exam Papers Practice

To be used by all students preparing for DP IB Biology HL
Students of other boards may also find this useful

Question 1

A piece of DNA was analysed to find the number of nucleotide bases in each of the polynucleotide strands. Some of the results are shown below.

	Number of nucleotide bases			
	A	T	G	C
Strand 1		30	22	
Strand 2		30	38	

What is the maximum number of amino acids that could be coded for by this DNA?

- A. 30
- B. 35
- C. 40
- D. 50

[1 mark]

Question 2

What is the correct sequence for the processes involved in the formation of a protein?

- A. transcription → peptide bonding → translation → ionic bonding
- B. transcription → translation → peptide bonding → hydrogen bonding
- C. transcription → peptide bonding → translation → hydrogen bonding
- D. translation → peptide bonding → transcription → ionic bonding

[1 mark]

Question 3

Which of the following statements about transcription are true?

- I. DNA remains in the nucleus because it is too large to fit through the pores in the nuclear envelope.
- II. Transcription makes a copy of the sense strand of DNA.
- III. Transcription converts a sequence of nucleotides into a sequence of amino acids.
- IV. RNA polymerase forms covalent bonds between the RNA nucleotides.

- A. II only
- B. I and IV
- C. I, II and III
- D. I, II and IV

[1 mark]

Question 4

What terminates the formation of a polypeptide chain during protein synthesis in cells?

- A. When the ribosome reaches the end of the mRNA molecule.
- B. When there are no more tRNA molecules.
- C. When the ribosome reaches a stop codon on the mRNA.
- D. RNA polymerase detaches the polypeptide chain from the ribosome.

[1 mark]

Exam Papers Practice

Question 5

In 1957, Meselson and Stahl conducted an experiment that provided overwhelming evidence to support the theory that DNA replication is semi-conservative. They used *E. coli* which has a generation time of around one hour.

Here are the steps in their experiment in a mixed-up order:

1. Bacteria contain either all ^{14}N DNA or hybrid DNA
2. Bacteria grown in a ^{15}N medium for many generations
3. Bacteria transferred to a ^{14}N medium and sampled every hour
4. All bacteria contain hybrid DNA (^{14}N DNA and ^{15}N DNA).
5. All bacteria contain ^{15}N DNA

Which is the correct order of the processes?

- A. 4 → 3 → 1 → 2 → 5
- B. 2 → 1 → 3 → 4 → 5
- C. 5 → 4 → 3 → 1 → 2
- D. 2 → 5 → 3 → 4 → 1

[1 mark]

Question 6

Which of the following drawings best represents the structure of a section of DNA?

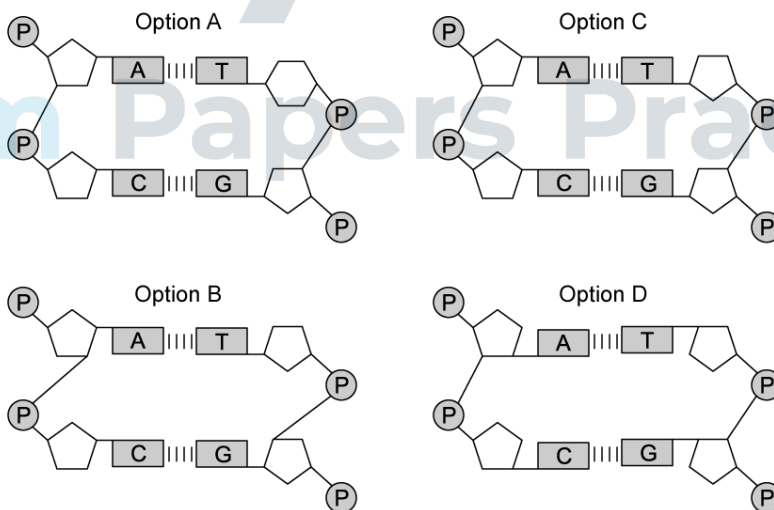

[1 mark]

Question 7

A base substitution mutation has caused a single change to the mRNA transcript of a section of a gene, as shown below.

Original sequence AUGGAAAUACCGCCAGGA

Mutated sequence AUGGAAAUACUGCCAGGA

		Second letter					
		U	C	A	G		
First letter	U	UUU } Phe UUC } UUA } Leu UUG }	UCU } Ser UCC } UCA } UCG }	UAU } Tyr UAC } UAA } Stop UAG } Stop	UGU } Cys UGC } UGA } Stop UGG } Trp	U C A G	
	C	CUU } Leu CUC } CUA } CUG }	CCU } CCC } CCA } Pro CCG }	CAU } His CAC } CAA } Gln CAG }	CGU } CGC } CGA } Arg CGG }	U C A G	
	A	AUU } AUC } Ile AUA } AUG } Met	ACU } ACC } Thr ACA } ACG }	AAU } Asn AAC } AAA } Lys AAG }	AGU } Ser AGC } AGA } Arg AGG }	U C A G	
	G	GUU } GUC } Val GUA } GUG }	GCU } Ala GCC } GCA } GCG }	GAU } Asp GAC } GAA } Glu GAG }	GGU } GGC } GGA } Gly GGG }	U C A G	
						Third letter	

Using the table above, what is the change in amino acid sequence caused by this mutation?

- A. Pro → Leu
- B. Met → Glu
- C. Pro → Gln
- D. No change

[1 mark]

Question 8

Which row of the table contains three correct statements about DNA replication, transcription and translation?

	DNA replication	Transcription	Translation
A	produces mRNA	occurs in the cytoplasm	tRNA involved
B	DNA polymerase involved	RNA polymerase involved	produces mRNA
C	is semi-conservative	produces mRNA	occurs at a ribosome
D	occurs in the nucleus	occurs in the nucleus	RNA polymerase involved

[1 mark]

Question 9

Which of the following statements about the genetic code are correct?.

- I. A single DNA base will always be transcribed and translated in eukaryotic organisms.
- II. A single DNA base can be part of genes that overlap each other.
- III. The genetic code allows multiple triplet codons to code for a single amino acid.
- IV. The genetic code in a eukaryotic organism's genome stays the same throughout the organism's life.

- A. III only
- B. I and IV
- C. I, II and III
- D. III and IV

[1 mark]

Question 10

The laboratory technique of Polymerase Chain Reaction (PCR) takes advantage of the ability of polymerase enzymes to copy pieces of genetic material quickly and accurately. Which of the following are necessary for successfully conducting PCR in a forensic examination at a crime scene?

- I. An active sample of human DNA or RNA polymerase
- II. Buffer solution
- III. A sample of target DNA or RNA
- IV. Free nucleotides
- V. Primer sequences

- A. I, III, IV
- B. II, III, IV and V
- C. I, II, III and IV
- D. All of them

[1 mark]