

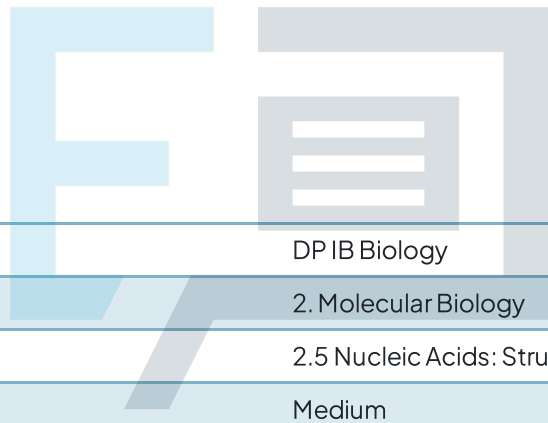

# 2.5 Nucleic Acids: Structure & DNA Replication

## Question Paper



Course	DP IB Biology
Section	2. Molecular Biology
Topic	2.5 Nucleic Acids: Structure & DNA Replication
Difficulty	Medium

# Exam Papers Practice

To be used by all students preparing for DP IB Biology HL  
Students of other boards may also find this useful

### Question 1

A short piece of DNA 19 base pairs long was analysed to find the number of nucleotide bases in each of the polynucleotide strands. Some of the results are shown below.

	Number of nucleotide bases			
	A	T	G	C
Strand 1	8	-	-	-
Strand 2	-	8	3	4

How many nucleotides containing adenine (A) were present in strand 2?

- A. 2
- B. 4
- C. 6
- D. 8

[1 mark]

### Question 2

Which activity was **not** a direct contributor to Crick and Watsons' discovery of the double-helix structure of DNA?

- A. Thin-layer chromatography.
- B. X-ray molecular analysis.
- C. Building physical models with clamps and stands.
- D. Collaboration with scientists in other research institutions.

[1 mark]

### Question 3

Which of the following would be a result of analysing a DNA molecule?

- A. An equal ratio of pentose sugars to phosphates and an equal ratio of thymine to adenine bases.
- B. Twice as many pentose sugars as phosphates and an equal ratio of guanine to cytosine bases.
- C. An equal ratio of hexose sugars to phosphates and an equal ratio of thymine to cytosine bases.
- D. Twice as many hexose sugars as phosphates and an equal ratio of guanine to adenine bases.

[1 mark]

#### Question 4

DNA is described as a double-helix, antiparallel structure. Which of the following statements best explains the term, 'antiparallel'?

- A. One strand possesses deoxyribose sugar, the opposite strand possesses ribose sugars.
- B. The nitrogenous bases invert their orientation on the sense strand versus the antisense strand.
- C. The alignment of the sugar-phosphate backbone of each strand runs in opposite directions.
- D. The alignment of the two strands of nucleotides runs in opposite directions.

[1 mark]

#### Question 5

The approximate angle of orientation ('twist') of one nucleotide in respect to its neighbouring nucleotide in a given strand of DNA is between 35 and 40 degrees. How many base pairs are required for the double-helix to twist by one whole turn?

- A. 5
- B. 8
- C. 10
- D. 12

[1 mark]

#### Question 6

Which of the following statements about semi-conservative replication of DNA are correct?

- I. DNA polymerase always works in the same direction along a strand of DNA, in the 3' to 5' direction.
- II. The action of DNA polymerase is followed by that of helicase.
- III. One strand of original DNA remains in each daughter molecule; the other strand has been made from free nucleotides.
- IV. Crick and Watson proposed the hypothesis of semi-conservative replication, whereas experimental evidence was later provided by Meselson and Stahl.

- A. I, III and IV
- B. I and III
- C. III and IV
- D. I, II and IV

[1 mark]

### Question 7

The diagram shows part of an RNA molecule.

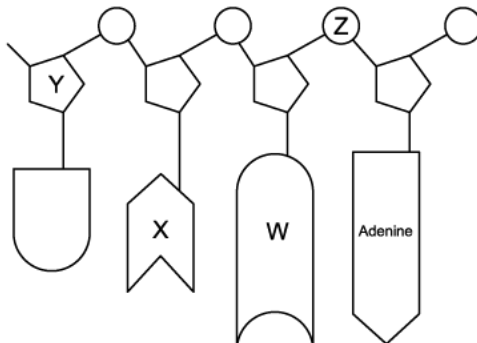

Which row of the table below is correct?

	Uracil	Phosphate	Ribose	Guanine
<b>A</b>	W	Z	Y	X
<b>B</b>	W	Y	Z	X
<b>C</b>	X	Z	Y	W
<b>D</b>	X	Y	Z	W

[1 mark]

### Question 8

During the process of semi-conservative replication of DNA, which activity, relating to bonding, does **not** take place?.

- A. Breaking of hydrogen bonds.
- B. DNA polymerase forms an enzyme-substrate complex with free nucleotides.
- C. Formation of new covalent bonds between nucleotides.
- D. Formation of new glycosidic bonds between deoxyribose molecules.

[1 mark]

### Question 9

The table shows the percentages of bases in DNA samples from various organisms.

Source of DNA	Adenine	Cytosine	Guanine	Thymine
Human liver	30	20	20	<b>Z</b>
Chicken liver	<b>W</b>	40	40	10
Dog liver	24	26	24	26
Mouse bone marrow	23	<b>X</b>	26	25
Sunflower leaf	10	39	<b>Y</b>	12

Which row of the table below correctly reflects the missing data values?

	<b>W</b>	<b>X</b>	<b>Y</b>	<b>Z</b>
<b>A</b>	9	24	38	30
<b>B</b>	10	26	39	31
<b>C</b>	10	26	39	30
<b>D</b>	10	25	38	29

[1 mark]

**Question 10**

The simplified diagram represents a section of DNA in 2D form.

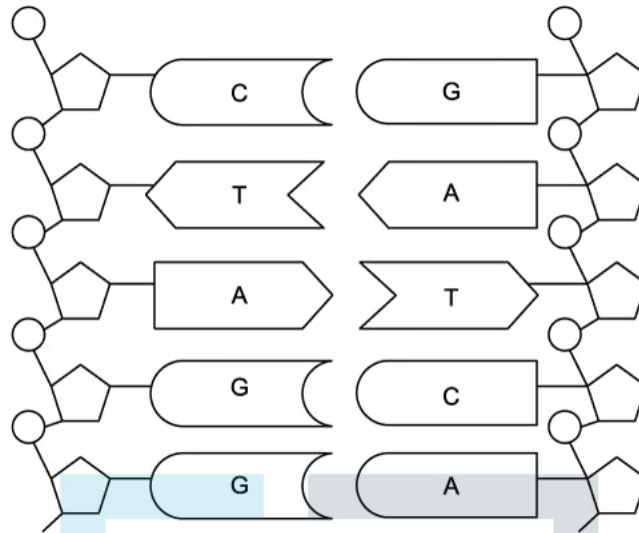

How many mistakes are there in this diagram?

- A. 0
- B. 1
- C. 3
- D. 5

[1 mark]